

	SBT 6-22 SF 6-(A)22
	Torque tool 8Nm / 5.9 ft-lb
	S-NS 19 95/3 1/4"
	S-CG / X-BT PRG
	HDM
	HDE

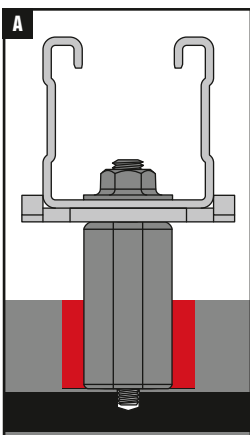

	Torque tool - 20Nm / 14.8 ft-lb
	S-NS 15
	C 95/3 1/4" (M10)
	S-NS 9/16" (W10)
	C 95/3 1/4" (W10)
	SW 19
	MQZ-L11-R/F
	MQ Channel
	M10/W10 Flange nut

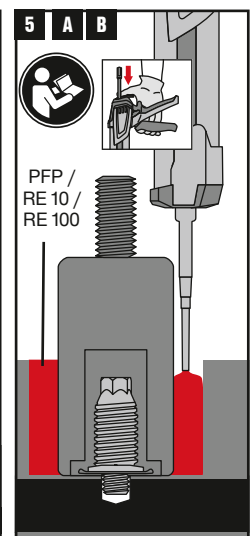
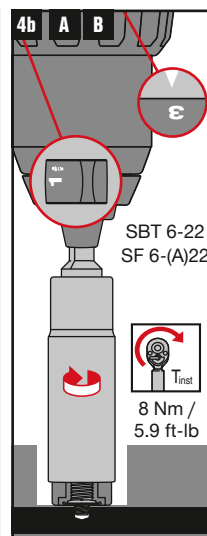
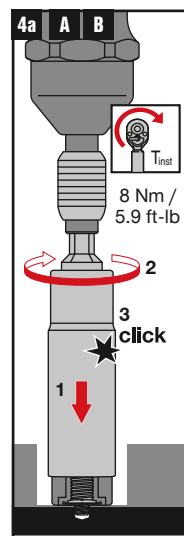
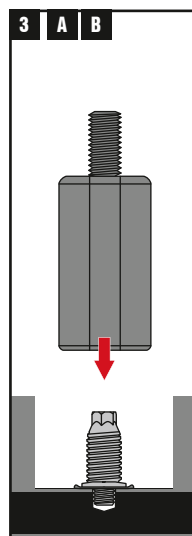
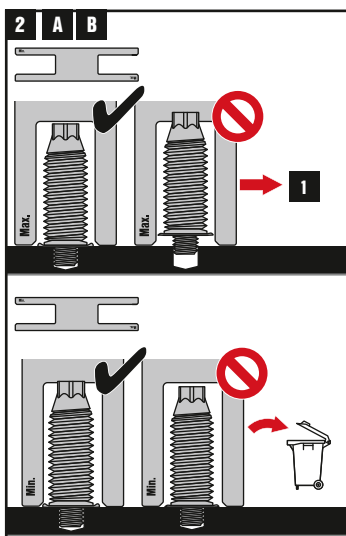
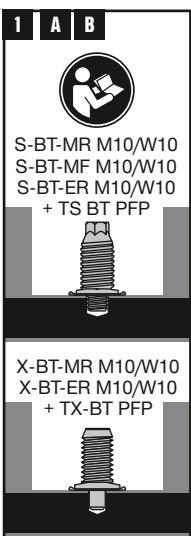
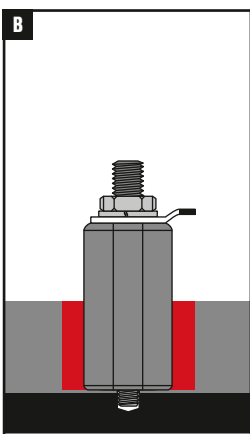
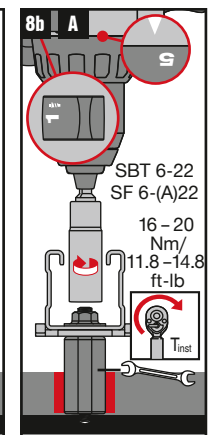
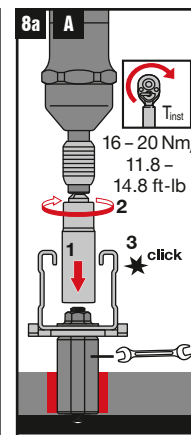
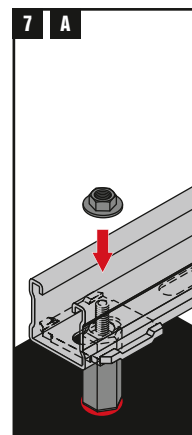
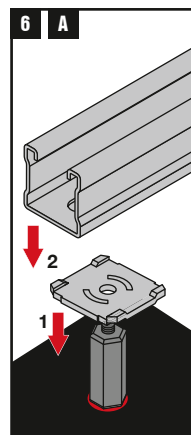

	Torque tool - 16Nm / 11.8 ft-lb
	S-NS 15
	C 95/3 1/4" (M10)
	S-NS 9/16" (W10)
	C 95/3 1/4" (W10)
	SW 19
	2x Hex Thin nut M10/W10-R
	1x Spring washer M10/W10-R

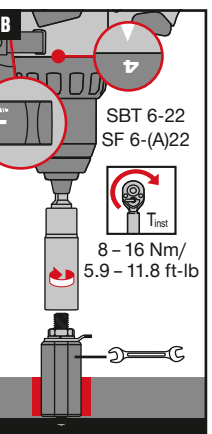
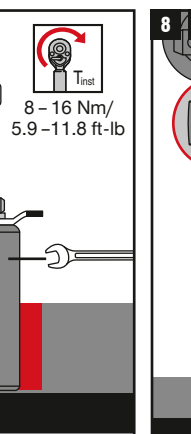
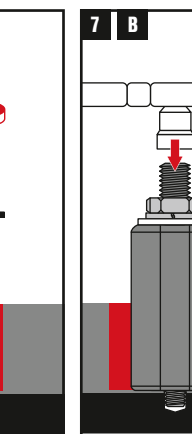
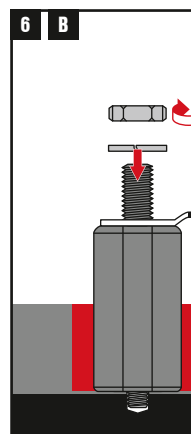

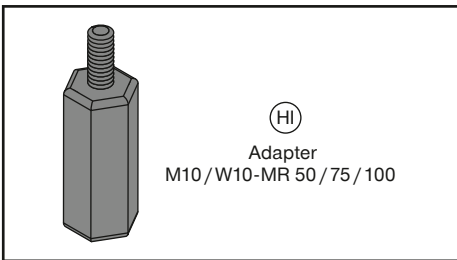
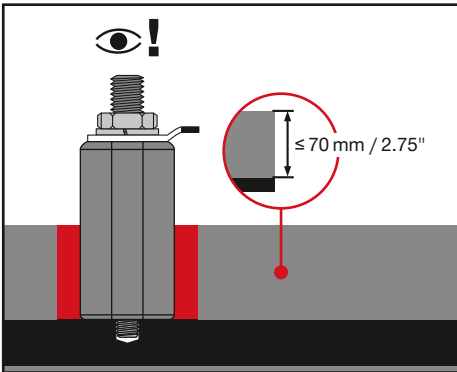

S-BT-ER M10/W10	X-BT-ER M10/W10
SBT 6-22 SF 6-(A)22	SF BT 22-A
TS-BT 5.3 HC 95	TX-BT 4.7 HC 95
S-CG	X-BT PRG

	Torque tool - 8 Nm / 5.9 ft-lb (adapter) - 16 Nm / 11.8 ft-lb (nut)
	S-NS 19 95 / 3 1/4" (adapter)
	S-NSD 17 1/4" HKH (M10 nut)
	S-NS 9/16" C 95/3 3/4" (W10 nut)
	HDM
	HDE
1.	2× Hex Thin nut M8-R
2.	1× Spring washer M8-R
	SW 19

