

**DEKLARACJA WŁAŚCIWOŚCI UŻYTKOWYCH**

Zgodnie z załącznikiem III do rozporządzenia (UE) nr 305/2011 (Wyroby budowlane)

**Opaska ogniochronna Hilti CFS-W**

Nr Hilti CFS-W "0843-CPD-0103"

**1. Niepowtarzalny kod identyfikacyjny typu wyrobu:**

Opaska ogniochronna Hilti CFS-W

**2. Zamierzone zastosowanie lub zastosowania:**

Ogniochronne uszczelnienia przejść instalacyjnych, patrz ETA-10/0405 (28.06.2018)

Przepusty dla rur	Nieizolowane rury plastikowe
-------------------	------------------------------

**3. Producent:**

HILTI Corporation, Feldkircherstrasse 100, 9494 Schaan, Księstwo Liechtenstein

**4. System(-y) oceny i weryfikacji stałości właściwości użytkowych:**

System 1

**5. Europejski dokument oceny:**

EAD 350454-00-1104 „Produkty do ogniochronnych uszczelnień przejść instalacyjnych”

Europejska Ocena Techniczna:

ETA-10/0405 (28.06.2018)

**Jednostka ds. oceny technicznej:**

OIB Austriacki Instytut Techniki Budowlanej

**Jednostka lub jednostki notyfikowane:**

MPA Braunschweig, Nr 0761

**6. Deklarowane właściwości użytkowe:**

Zasadnicze charakterystyki	Deklarowane właściwości użytkowe / zharmonizowana specyfikacja techniczna
Reakcja na działanie ognia	Klasa E według EN 13501-1
Odporność ogniowa	Klasyfikacja odporności ogniowej oraz obszar zastosowań według EN 13501-2. Patrz Załącznik.
Trwałość i użyteczność	Y <sub>2</sub> , wg EAD350454 350454-00-1104. Patrz Załącznik.

Właściwości użytkowe określonego powyżej wyrobu są zgodne z zestawem deklarowanych właściwości użytkowych. Niniejsza deklaracja właściwości użytkowych wydana zostaje zgodnie z rozporządzeniem (UE) nr 305/2011 na wyłączną odpowiedzialność producenta określonego powyżej.

W imieniu producenta podpisał(-a):

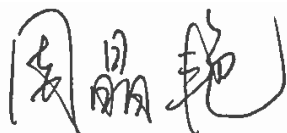

Jingyan Zhou  
Manager produktów  
Dział ochrony przeciwpożarowej  
Hilti Corporation



Martin Althof  
Kierownik Działu Jakości  
Dział ochrony przeciwpożarowej  
Hilti Corporation

## Intended use

“Hilti Firestop Wrap CFS-W” is intended to be used as a pipe penetration seal around plastic pipes to temporarily or permanently reinstate the fire resistance performance of wall and floor constructions, where they have been provided with apertures for the penetration of plastic pipes.

The maximum opening size of the penetration seal is related to a maximum pipe diameter of 160 mm with an annular gap of up to 9,5 mm. For more details regarding the maximum opening size, see Annex C of the ETA.

“Hilti Firestop Wrap CFS-W” can be installed only in the types of separating elements as specified in the following table.

Separating element	Construction
Flexible walls	<ul style="list-style-type: none"><li>&gt; Steel studs or timber studs lined on both faces with minimum 2 layers of boards (minimum thickness 12,5 mm) according to EN 520 type F</li><li>&gt; For steel stud walls the space between lining must not be completely filled with insulation material, especially in the adjacent area of the penetration seal</li><li>&gt; For timber studs walls there must be a minimum distance of 100 mm of the penetration seal to any timber stud. The cavity between the penetration seal and stud has to be closed with minimum of 100 mm of insulation with classification A1 or A2 according to EN 13501-1</li><li>&gt; Minimum thickness 100 mm</li></ul>
Rigid walls	<ul style="list-style-type: none"><li>&gt; Aerated concrete, concrete, masonry</li><li>&gt; Minimum density 650 kg/m<sup>3</sup> (wall type A)</li><li>&gt; Minimum thickness dependent on specific application according to Annex C of the ETA</li><li>&gt; The rigid wall shall be classified in accordance with EN 13501-2 for the required fire resistance period</li></ul>
Rigid walls	<ul style="list-style-type: none"><li>&gt; Concrete, concrete, masonry</li><li>&gt; Minimum density 1100 kg/m<sup>3</sup> (wall type B)</li><li>&gt; Minimum thickness dependent on specific application according to Annex C of the ETA</li><li>&gt; The rigid wall shall be classified in accordance with EN 13501-2 for the required fire resistance period</li></ul>
Rigid floors	<ul style="list-style-type: none"><li>&gt; Concrete</li><li>&gt; Minimum density 2400 kg/m<sup>3</sup> (floor type A) or 550 kg/m<sup>3</sup> (floor type B)</li><li>&gt; Minimum thickness dependent on specific application according to Annex C of the ETA</li><li>&gt; The rigid floor shall be classified in accordance with EN 13501-2 for the required fire resistance period</li></ul>

This European Technical Assessment does not cover sandwich panel constructions.

“Hilti Firestop Wrap CFS-W” can only be used as penetration seal for single plastic pipes. Further details are given in Annex C of the ETA. Other parts or service support constructions shall not penetrate the penetration seal.

The first support of the pipes shall be located at maximum 260 mm away from both faces of wall constructions and maximum 300 mm from the upper face of floor constructions, for details see Annex C of the ETA.

## Abbreviations used in drawings

Abbreviation	Description
A <sub>1</sub>	Hilti Firestop Wrap CFS-W
A <sub>2</sub>	Annular gap seal with Hilti Firestop Acrylic Sealant CFS-S ACR
A <sub>3</sub>	Annular gap seal with cementitious mortar
B	Backfilling material (mineral wool)
C	Plastic Pipe
d <sub>c</sub>	Pipe diameter (nominal outside diameter)
E	Building element (wall, floor)
s <sub>1</sub>	Minimum distance between single penetration seals
t <sub>A2</sub>	Thickness of Hilti Firestop Acrylic Sealant CFS-S ACR
t <sub>c</sub>	Pipe wall thickness
t <sub>E</sub>	Thickness of the building element

## RESISTANCE TO FIRE CLASSIFICATION OF PENETRATION SEALS MADE OF HILTI FIRESTOP WRAP CFS-W

### C.1 Flexible walls and rigid walls type A according to clause 2.1 of the ETA, minimum wall thickness 100 mm

#### Penetration seal - Single penetration:

– Hilti Firestop Wrap CFS-W on both sides ( $A_1$ ), outer edge of the wrap flush with the surface of the wall.

– Annular gap filled within:

- *Flexible walls (see construction details below):*

Hilti Firestop Acrylic Sealant CFS-S ACR ( $A_2$ ) on both sides with a depth ( $t_{A2}$ ) of minimum 25 mm from the surface of the wall supported by mineral wool of minimum  $100 \text{ kg/m}^3$  density in the gap between the wall lining around the opening with a depth of minimum 100 mm;

- *Rigid walls (see construction details below):*

Cementitious mortar ( $A_3$ ) over the entire thickness of the wall or Hilti Firestop Acrylic Sealant CFS-S ACR ( $A_2$ ) on both sides with a depth ( $t_{A2}$ ) of minimum 15 mm from the surface of the wall. The sealant may be backfilled with mineral wool (for suitable mineral wool products see Annex B.3 of the ETA).

– The maximum annular gap width is given in the tables below;

– Minimum distance between single penetration seals ( $s_1$ ): 200 mm.

#### Construction details:

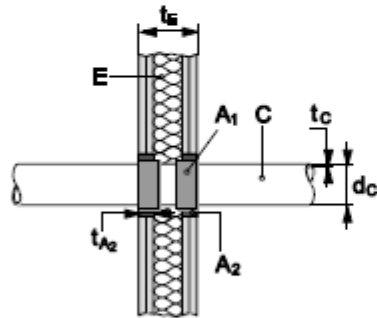

Application in a flexible wall (with Hilti Firestop Acrylic Sealant CFS-S ACR -  $A_2$ )

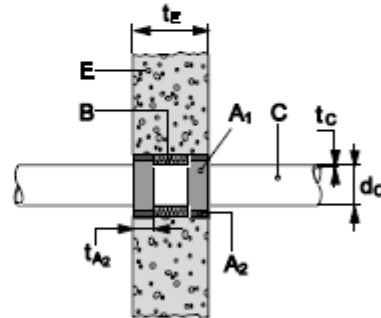

Application in a rigid wall (with Hilti Firestop Acrylic Sealant CFS-S ACR -  $A_2$ )

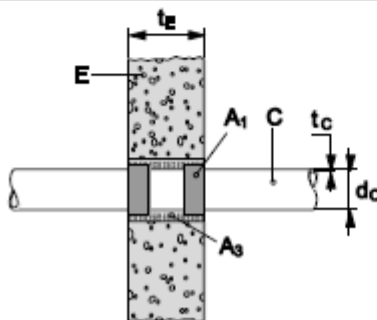

Application in a rigid wall (with cementitious mortar -  $A_3$ )

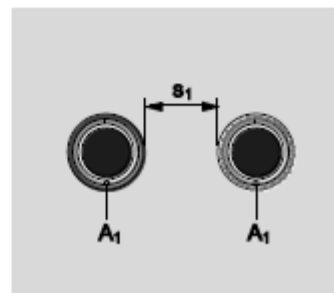

## Penetrating services

### C.1.1 PVC-U pipes according to EN ISO 15493, EN ISO 1452 and DIN 8061/8062

Distance between wrap and penetration seal edge in wall (width of annular gap):  $\leq 9,5$  mm.

Pipe diameter $d_c$ (mm)	Pipe wall thickness $t_c$ (mm)	Type of CFS-W (A <sub>1</sub> )	Size (CFS-W SG) / No. of layers (CFS-W EL)	Classification
50	2,2 – 3,6	CFS-W SG	50/1.5"	EI 120-U/C
63	2,2 – 3,6	CFS-W SG	63/2"	EI 120-U/C
75	2,2 – 3,6	CFS-W SG	75/2.5"	EI 120-U/C
$\leq 75$	2,2 – 3,6	CFS-W EL	1	EI 120-U/C
90	3,7 – 6,0	CFS-W SG	90/3"	EI 90-U/C
110	3,7 – 6,0	CFS-W SG	110/4"	EI 90-U/C
125	3,7 – 6,0	CFS-W SG	125/5"	EI 90-U/C
$>75 \leq 125$	3,7 – 6,0	CFS-W EL	2	EI 90-U/C
160	2,5 – 11,8	CFS-W SG	160/6"	EI 60-U/C
$> 125 \leq 160$	2,5 – 11,8	CFS-W EL	3	EI 60-U/C
160	11,8	CFS-W SG	160/6"	EI 90-U/C
160	11,8	CFS-W EL	3	EI 90-U/C

The results are also valid for PVC-C pipes according to EN 1566-1<sup>3</sup> and PVC-U pipes according to EN 1329-1<sup>4</sup> and EN 1453-1<sup>4</sup>.

### C.1.2 PE pipes according to EN ISO 15494 and DIN 8074/8075

Distance between wrap and penetration seal edge in wall (width of annular gap):  $\leq 9,5$  mm.

Pipe diameter $d_c$ (mm)	Pipe wall thickness $t_c$ (mm)	Type of CFS-W (A <sub>1</sub> )	Size (CFS-W SG) / No. of layers (CFS-W EL)	Classification
50	1,9 – 6,8	CFS-W SG	50/1.5"	EI 120-U/C
63	1,9 – 6,8	CFS-W SG	63/2"	EI 120-U/C
75	1,9 – 6,8	CFS-W SG	75/2.5"	EI 120-U/C
$\leq 75$	1,9 – 6,8	CFS-W EL	1	EI 120-U/C
90	3,2 – 7,1	CFS-W SG	90/3"	EI 120-U/C
110	3,2 – 7,1	CFS-W SG	110/4"	EI 120-U/C
125	3,2 – 7,1	CFS-W SG	125/5"	EI 120-U/C
$>75 \leq 125$	3,2 – 7,1	CFS-W EL	2	EI 120-U/C
160	4,0 – 9,1	CFS-W SG	160/6"	EI 60-U/C
$> 125 \leq 160$	4,0 – 9,1	CFS-W EL	3	EI 60-U/C
160	9,1	CFS-W SG	160/6"	EI 90-U/C
160	9,1	CFS-W EL	3	EI 90-U/C

<sup>3</sup> It is recommended only to use gypsum plaster or cementitious mortar as annular gap seal for PVC-C pipes together with sound decoupling according to Annex B.5 of the ETA

<sup>4</sup> In Germany the pipes have additionally to comply with DIN 19531-10

### C.1.3 PE pipes according to EN 1519-1<sup>5</sup>

Distance between wrap and penetration seal edge in wall (width of annular gap):  $\leq 4,5$  mm.

Pipe diameter $d_c$ (mm)	Pipe wall thickness $t_c$ (mm)	Type of CFS-W ( $A_1$ )	Size (CFS-W SG) / No. of layers (CFS-W EL)	Classification
50	3,0	CFS-W SG	50/1.5"	EI 120-U/C
63	3,0	CFS-W SG	63/2"	EI 120-U/C
75	3,0	CFS-W SG	75/2.5"	EI 120-U/C
$\leq 75$	3,0	CFS-W EL	1	EI 120-U/C
90	4,9	CFS-W SG	90/3"	EI 120-U/C
110	4,9	CFS-W SG	110/4"	EI 120-U/C
125	4,9	CFS-W SG	125/5"	EI 120-U/C
$>75 \leq 125$	4,9	CFS-W EL	2	EI 120-U/C

The results are also valid for PE pipes according to EN 12201-2 and EN 12666-1.

## C.2 Rigid walls according to clause 2.1 of the ETA

### Penetration seal - Single penetration:

- Hilti Firestop Wrap CFS-W on both sides ( $A_1$ )
- Annular gap filled either with cementitious mortar ( $A_3$ ) over the entire thickness of the wall or with Hilti Firestop Acrylic Sealant CFS-S ACR ( $A_2$ ) with a depth of minimum 15 mm from the surface of the wall. The sealant may be backfilled with mineral wool (for suitable mineral wool products see Annex B.3 of the ETA). The maximum annular gap width is given in the tables below;
- Minimum distance between single penetration seals ( $s_1$ ): 200 mm;
- For further construction details see Annex C.1 of the ETA.

### C.2.1 Rigid walls type A according to clause 2.1 of the ETA (density $\geq 650$ kg/m<sup>3</sup>), minimum wall thickness 150 mm

#### Penetrating services

#### C.2.1.1 PVC-U pipes according to EN ISO 15493, EN ISO 1452 and DIN 8061/8062

Distance between wrap and penetration seal edge in wall (width of annular gap):  $\leq 7,5$  mm

Pipe diameter $d_c$ (mm)	Pipe wall thickness $t_c$ (mm)	Type of CFS-W ( $A_1$ )	Size (CFS-W SG) / No. of layers (CFS-W EL)	Classification
160	2,5 – 11,8	CFS-W SG	160/6"	EI 180-U/C
$> 125 \leq 160$	2,5 – 11,8	CFS-W EL	3	EI 180-U/C

The results are also valid for PVC-C pipes according to EN 1566-1<sup>3</sup> and PVC-U pipes according to EN 1329-1<sup>4</sup> and EN 1453-1<sup>4</sup>.

**C.2.1.2 PE pipes according to EN ISO 15494 and DIN 8074/8075**Distance between wrap and seal edge in wall (width of annular gap):  $\leq 7,5$  mm

Pipe diameter $d_c$ (mm)	Pipe wall thickness $t_c$ (mm)	Type of CFS-W ( $A_1$ )	Size (CFS-W SG) / No. of layers (CFS-W EL)	Classification
160	4,0 – 9,1	CFS-W SG	160/6"	EI 180-U/C
$> 125 \leq 160$	4,0 – 9,1	CFS-W EL	3	EI 180-U/C

**C.2.1.3 PE pipes according to EN 1519-1<sup>5</sup>**Distance between wrap and penetration seal edge in wall (width of annular gap):  $\leq 7,5$  mm

Pipe diameter $d_c$ (mm)	Pipe wall thickness $t_c$ (mm)	Type of CFS-W ( $A_1$ )	Size (CFS-W SG) / No. of layers (CFS-W EL)	Classification
160	6,2	CFS-W SG	160/6"	EI 180-U/C
$> 125 \leq 160$	6,2	CFS-W EL	3	EI 180-U/C

The results are also valid for PE pipes according to EN 12201-2 and EN 12666-1.

**C.2.2 Rigid walls type B according to clause 2.1 of the ETA (density  $\geq 1100$  kg/m<sup>3</sup>), minimum wall thickness 175 mm****Penetrating services****C.2.2.1 PVC pipes according to EN ISO 15493, EN ISO 1452 and DIN 8061/8062**Distance between wrap and penetration seal edge in wall (width of annular gap):  $\leq 8,5$  mm

Pipe diameter $d_c$ (mm)	Pipe wall thickness $t_c$ (mm)	Type of CFS-W ( $A_1$ )	Size (CFS-W SG) / No. of layers (CFS-W EL)	Classification
$\leq 32$	1,8	CFS-W EL	1	EI 240-U/C
90	3,2	CFS-W SG	90/3"	EI 240-U/C
110	3,2	CFS-W SG	110/4"	EI 240-U/C
$> 75 \leq 110$	3,2	CFS-W EL	2	EI 240-U/C
160	3,2 – 13,0	CFS-W SG	160/6"	EI 240-U/C
$> 125 \leq 160$	3,2 – 13,0	CFS-W EL	3	EI 240-U/C

The results are also valid for PVC-C pipes according to EN 1566-1<sup>3</sup> and PVC-U pipes according to EN 1329-1<sup>4</sup> and EN 1453-1<sup>4</sup>.

### C.2.2.2 PE pipes according to EN ISO 15494 and DIN 8074/8075

Distance between wrap and penetration seal edge in wall (width of annular gap):  $\leq 8,5$  mm

Pipe diameter $d_c$ (mm)	Pipe wall thickness $t_c$ (mm)	Type of CFS-W ( $A_1$ )	Size (CFS-W SG) / No. of layers (CFS-W EL)	Classification
$\leq 32$	1,8	CFS-W EL	1	EI 240-U/C
90	2,7	CFS-W SG	90/3"	EI 240-U/C
110	2,7	CFS-W SG	110/4"	EI 240-U/C
$> 75 \leq 110$	2,7	CFS-W EL	2	EI 240-U/C
160	4,0 – 14,6	CFS-W SG	160/6"	EI 240-U/C
$> 125 \leq 160$	4,0 – 14,6	CFS-W EL	3	EI 240-U/C

### C.3 Rigid floors according to clause 2.1 of the ETA

#### Penetration seal - Single penetration:

- Hilti Firestop Wrap CFS-W ( $A_1$ ) on the underside of the floor;
- Annular gap filled either with cementitious mortar ( $A_3$ ) over the entire thickness of the floor or;
- with Hilti Firestop Acrylic Sealant CFS-S ACR ( $A_2$ ) with a depth ( $t_{A2}$ ) of minimum 15 mm from the surface of the floor. The gap behind the sealant is to be backfilled with mineral wool compressed to achieve minimum  $60 \text{ kg/m}^3$  density. The maximum annular gap width is given in the tables below;
- Minimum distance between single penetration seals ( $s_1$ ): 200 mm (see figure in Annex C.1 of the ETA).

#### Construction details:

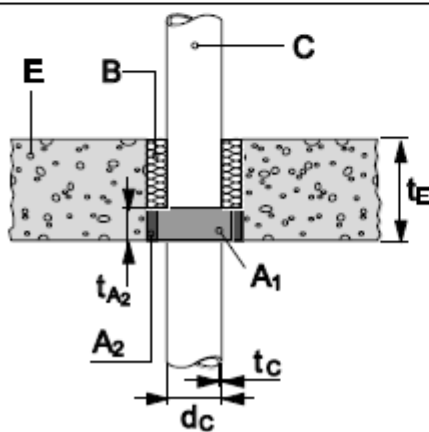

Application in a rigid floor (with Hilti Firestop Acrylic Sealant CFS-S ACR -  $A_2$ )

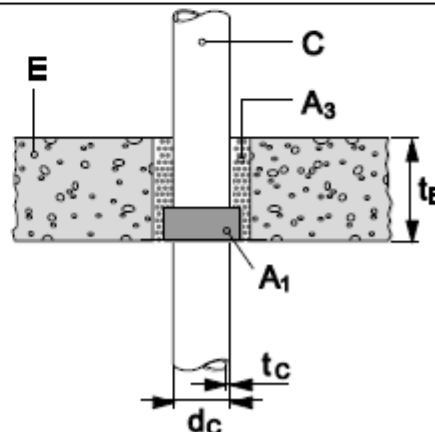

Application in a rigid floor (with cementitious mortar -  $A_3$ )



**C.3.1 Rigid floor type A according to clause 2.1 of the ETA (density  $\geq 2400 \text{ kg/m}^3$ ), minimum floor thickness 150 mm**

**Penetrating services**

**C.3.1.1 PVC-U pipes according to EN ISO 15493, EN ISO 1452 and DIN 8061/8062**

Distance between wrap and penetration seal edge in floor (width of annular gap):  $\leq 9,5 \text{ mm}$  ( $\varnothing 90 - 125 \text{ mm}$ )

Distance between wrap and penetration seal edge in floor (width of annular gap):  $\leq 1,5 \text{ mm}$  ( $\varnothing > 125 \text{ mm}$ )

Pipe diameter $d_c$ (mm)	Pipe wall thickness $t_c$ (mm)	Type of CFS-W ( $A_1$ )	Size (CFS-W SG) / No. of layers (CFS-W EL)	Classification
90	3,7 – 6,0	CFS-W SG	90/3"	EI 120-U/C
110	3,7 – 6,0	CFS-W SG	110/4"	EI 120-U/C
125	3,7 – 6,0	CFS-W SG	125/5"	EI 120-U/C
$> 75 \leq 125$	3,7 – 6,0	CFS-W EL	2	EI 120-U/C
160	3,2 – 4,0	CFS-W SG	160/6"	EI 120-U/C
$> 125 \leq 160$	3,2 – 4,0	CFS-W EL	3	EI 120-U/C

The results are also valid for PVC-C pipes according to EN 1566-1<sup>3</sup> and PVC-U pipes according to EN 1329-1<sup>4</sup> and EN 1453-1<sup>4</sup>.

**C.3.1.2 PE pipes according to EN ISO 15494 and DIN 8074/8075**

Distance between wrap and seal edge in floor (width of annular gap):  $\leq 9,5 \text{ mm}$

Pipe diameter $d_c$ (mm)	Pipe wall thickness $t_c$ (mm)	Type of CFS-W ( $A_1$ )	Size (CFS-W SG) / No. of layers (CFS-W EL)	Classification
90	7,1	CFS-W SG	90/3"	EI 120-U/C
110	7,1	CFS-W SG	110/4"	EI 120-U/C
125	7,1	CFS-W SG	125/5"	EI 120-U/C
$> 75 \leq 125$	7,1	CFS-W EL	2	EI 120-U/C

**C.3.1.3 PE pipes according to EN 1519-1<sup>5</sup>**Distance between wrap and penetration seal edge in floor (width of annular gap):  $\leq 3,5$  mm

Pipe diameter $d_c$ (mm)	Pipe wall thickness $t_c$ (mm)	Type of CFS-W ( $A_1$ )	Size (CFS-W SG) / No. of layers (CFS-W EL)	Classification
50	3,0	CFS-W SG	50/1.5"	EI 120-U/C
63	3,0	CFS-W SG	63/2"	EI 120-U/C
75	3,0	CFS-W SG	75/2.5"	EI 120-U/C
$\leq 75$	3,0	CFS-W EL	1	EI 120-U/C
90	4,8	CFS-W SG	90/3"	EI 120-U/C
110	4,8	CFS-W SG	110/4"	EI 120-U/C
125	4,8	CFS-W SG	125/5"	EI 120-U/C
$> 75 \leq 125$	4,8	CFS-W EL	2	EI 120-U/C
160	6,2	CFS-W SG	160/6"	EI 120-U/C
$> 125 \leq 160$	6,2	CFS-W EL	3	EI 120-U/C

The results are also valid for PE pipes according to EN 12201-2 and EN 12666-1.

**C.3.2 Rigid floor type A according to clause 2.1 of the ETA (density  $\geq 2400$  kg/m<sup>3</sup>),  
minimum floor thickness 200 mm****Penetrating services****C.3.2.1 PVC-U pipes according to EN ISO 15493, EN ISO 1452 and DIN 8061/8062**Distance between wrap and seal edge in floor (width of annular gap):  $\leq 7,5$  mm

Pipe diameter $d_c$ (mm)	Pipe wall thickness $t_c$ (mm)	Type of CFS-W ( $A_1$ )	Size (CFS-W SG) / No. of layers (CFS-W EL)	Classification
$\leq 32$	1,8	CFS-W EL	1	EI 240-U/C
50	2,2 – 3,6	CFS-W SG	50/1.5"	EI 180-U/C
63	2,2 – 3,6	CFS-W SG	63/2"	EI 180-U/C
75	2,2 – 3,6	CFS-W SG	75/2.5"	EI 180-U/C
$\leq 75$	2,2 – 3,6	CFS-W EL	1	EI 180-U/C
90	3,2	CFS-W SG	90/3"	EI 240-U/C
90	3,2 – 6,0	CFS-W SG	90/3"	EI 180-U/C
110	3,2	CFS-W SG	110/4"	EI 240-U/C
110	3,2 – 6,0	CFS-W SG	110/4"	EI 180-U/C
$> 75 \leq 110$	3,2	CFS-W EL	2	EI 240-U/C
125	3,7 – 6,0	CFS-W SG	125/5"	EI 180-U/C
$> 75 \leq 125$	3,7 – 6,0	CFS-W EL	2	EI 180-U/C
160	2,5 – 3,2	CFS-W SG	160/6"	EI 60-U/C
$> 125 \leq 160$	2,5 – 3,2	CFS-W EL	3	EI 60-U/C
160	3,2 – 11,8	CFS-W SG	160/6"	EI 120-U/C
$> 125 \leq 160$	3,2 – 11,8	CFS-W EL	3	EI 120-U/C

160	11,8	CFS-W SG	160/6"	EI 180-U/C
> 125 ≤ 160	11,8	CFS-W EL	3	EI 180-U/C
160	11,8 – 13,0	CFS-W SG	160/6"	EI 120-U/C
> 125 ≤ 160	11,8 – 13,0	CFS-W EL	3	EI 120-U/C

The results are also valid for PVC-C pipes according to EN 1566-1<sup>3</sup> and PVC-U pipes according to EN 1329-1<sup>4</sup> and EN 1453-1<sup>4</sup>.

### C.3.2.2 PE pipes according to EN ISO 15494 and DIN 8074/8075

Distance between wrap and seal edge in floor (width of annular gap): ≤ 7,5 mm

Pipe diameter $d_c$ (mm)	Pipe wall thickness $t_c$ (mm)	Type of CFS-W ( $A_1$ )	Size (CFS-W SG) / No. of layers (CFS-W EL)	Classification
≤ 32	1,8	CFS-W EL	1	EI 240-U/C
50	1,9 – 6,8	CFS-W SG	50/1.5"	EI 180-U/C
63	1,9 – 6,8	CFS-W SG	63/2"	EI 180-U/C
75	1,9 – 6,8	CFS-W SG	75/2.5"	EI 180-U/C
≤ 75	1,9 – 6,8	CFS-W EL	1	EI 180-U/C
90	2,7	CFS-W SG	90/3"	EI 240-U/C
90	2,7 – 7,1	CFS-W SG	90/3"	EI 180-U/C
110	2,7	CFS-W SG	110/4"	EI 240-U/C
> 75 ≤ 110	2,7	CFS-W EL	2	EI 240-U/C
110	2,7 – 7,1	CFS-W SG	110/4"	EI 180-U/C
125	3,2 – 7,1	CFS-W SG	125/5"	EI 180-U/C
> 75 ≤ 125	3,2 – 7,1	CFS-W EL	2	EI 180-U/C
125	7,1	CFS-W SG	125/5"	EI 180-U/C
125	7,1	CFS-W EL	2	EI 180-U/C
160	4,0 – 14,6	CFS-W SG	160/6"	EI 180-U/C
> 125 ≤ 160	4,0 – 14,6	CFS-W EL	3	EI 180-U/C
160	14,6	CFS-W SG	160/6"	EI 240-U/C
> 125 ≤ 160	14,6	CFS-W EL	3	EI 240-U/C

### C.3.3 Rigid floor type B according to clause 2.1 of the ETA (density ≥ 550 kg/m<sup>3</sup>), minimum floor thickness 150 mm

#### Penetrating services

### C.3.3.1 PVC-U pipes according to EN ISO 15493, EN ISO 1452 and DIN 8061/8062

Distance between wrap and seal edge in floor (width of annular gap): ≤ 9,5 mm

Pipe diameter $d_c$ (mm)	Pipe wall thickness $t_c$ (mm)	Type of CFS-W ( $A_1$ )	Size (CFS-W SG) / No. of layers (CFS-W EL)	Classification
90	3,7 – 6,0	CFS-W SG	90/3"	EI 120-U/C
110	3,7 – 6,0	CFS-W SG	110/4"	EI 120-U/C
125	3,7 – 6,0	CFS-W SG	125/5"	EI 120-U/C
>75 ≤ 125	3,7 – 6,0	CFS-W EL	2	EI 120-U/C

160	4,0	CFS-W SG	160/6"	EI 120-U/C
>125 ≤ 160	4,0	CFS-W EL	3	EI 120-U/C
The results are also valid for PVC-C pipes according to EN 1566-1 <sup>3</sup> and PVC-U pipes according to EN 1329-1 <sup>4</sup> and EN 1453-1 <sup>4</sup> .				

### C.3.3.2 PE pipes according to EN ISO 15494 and DIN 8074/8075

Distance between wrap and penetration seal edge in floor (width of annular gap): ≤ 9,5 mm

Pipe diameter $d_c$ (mm)	Pipe wall thickness $t_c$ (mm)	Type of CFS-W ( $A_1$ )	Size (CFS-W SG) / No. of layers (CFS-W EL)	Classification
90	7,1	CFS-W SG	90/3"	EI 120-U/C
110	7,1	CFS-W SG	110/4"	EI 120-U/C
125	7,1	CFS-W SG	125/5"	EI 120-U/C
> 75 ≤ 125	7,1	CFS-W EL	2	EI 120-U/C