



PL

DEKLARACJA WŁAŚCIWOŚCI UŻYTKOWYCH

Nr HAC-C_2451-CPR-EAD-2017.0003

1. Niepowtarzalny kod identyfikacyjny typu wyrobu:

Hilti HAC-C

2. Zamierzone zastosowanie lub zastosowania:

Produkt	Przeznaczenie
Szyna kotwiąca	Do mocowania lub osadzania w betonie elementów konstrukcyjnych (przyczyniających się stabilności obiektu) lub elementów ciężkich.

3. Producent:

Hilti Corporation, Business Unit Anchors, 9494 Schaan, Księstwo Liechtenstein

4. System(-y) oceny i weryfikacji stałości właściwości użytkowych: System 1**5. Europejski dokument oceny:** EAD 330008-02-0601 (Wydanie 02-2016)**Europejska Ocena Techniczna:** ETA-17/0336 (11.07.2017)**Jednostka ds. oceny technicznej:** Deutsches Institut für Bautechnik (DIBt)**Jednostka lub jednostki notyfikowane:** NB 2451 - DVS Zert GmbH**6. Deklarowane właściwości użytkowe:****Wytrzymałość mechaniczna i stabilność (BWR 1)**

Zasadnicze charakterystyki	Właściwości użytkowe
Nośność charakterystyczna na obciążenia statyczne i quasi-statyczne, przemieszczenia	Patrz załącznik C1 do C6

Bezpieczeństwo pożarowe (BWR 2)

Zasadnicze charakterystyki	Właściwości użytkowe
Reakcja na działanie ognia	Połączenia kotwione spełniają wymagania dla Klasy A1
Odporność ogniowa	Patrz Załącznik C7

Właściwości użytkowe określonego powyżej wyrobu są zgodne z zestawem deklarowanych właściwości użytkowych. Niniejsza deklaracja właściwości użytkowych wydana zostaje zgodnie z rozporządzeniem (UE) nr 305/2011 na wyłączną odpowiedzialność producenta określonego powyżej.

W imieniu producenta podpisał(-a):

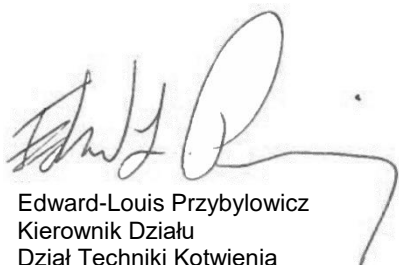

Edward-Louis Przybyłowicz
Kierownik Działu
Dział Techniki Kotwienia



Gunnar Wald
Kierownik Działu Jakości
Dział Techniki Kotwienia

Hilti Aktiengesellschaft
Schaan, 28.07.2017

Table 10: Characteristic resistances under tension load – steel failure of anchor channel

Anchor channel HAC-C			28/15	38/17	40/25	40/22	49/30	50/30	54/33	52/34
Steel failure: Failure of anchor										
Characteristic resistance	$N_{Rk,s,a}$	[kN]	9	18	20		31		55	
Partial safety factor	$\gamma_{Ms}^{1)}$	[-]	1,8							
Steel failure: Failure of connection between anchor and channel										
Characteristic resistance	$N_{Rk,s,c}$	[kN]	9	18	20		31		55	
Partial safety factor	$\gamma_{Ms,ca}^{1)}$	[-]	1,8							
Steel failure: Local failure by flexure of channel lips										
Characteristic spacing of the channel bolts for $N_{Rk,s,l}$	$s_{l,N}$	[mm]	56	76	80	79	100	98	107	105
Characteristic resistance	$N_{Rk,s,l}^0$	[kN]	9	18	20	35	31	36	55	65
Partial safety factor	$\gamma_{Ms,l}^{1)}$	[-]	1,8							

¹⁾ In absence of other national regulations

Table 11: Characteristic flexural resistance of channel under tension load

Anchor channel HAC-C			28/15	38/17	40/25	40/22	49/30	50/30	54/33	52/34	
Steel failure: Failure by flexure of channel											
Characteristic flexural resistance of channel	carbon steel	$M_{Rk,s,flex}$	[Nm]	316	538	979	1013	1669	2084	2929	3435
	stainless steel				527			1702		2832	
Partial safety factor	$\gamma_{Ms,flex}^{1)}$	[-]	1,15								

¹⁾ In absence of other national regulations

Anchor channels (HAC-C) with channel bolts (HBC)

Performance Data

Characteristic resistances of anchor channels under tension load

Annex C1

Table 12: Characteristic resistances under tension load – concrete failure

Anchor channel HAC-C			28/15	38/17	40/25	40/22	49/30	50/30	54/33	52/34		
Type of anchor			R	R	R	I	R	I	R	I	R	
Pullout failure												
Characteristic resistance in cracked concrete C12/15	N _{Rk,p}	[kN]	7,6	13,6	27,0	13,6	21,2	33,8	21,2	33,2	68,4	33,2
Characteristic resistance in uncracked concrete C12/15			10,7	19,0	37,8	19,0	29,7	47,3	29,7	46,5	95,8	46,5
Amplification factor of N _{Rk,p}	C16/20	ψ _c [-]	1,33									
	C20/25		1,67									
	C25/30		2,08									
	C30/37		2,50									
	C35/45		2,92									
	C40/50		3,33									
	C45/55		3,75									
	C50/60		4,17									
	≥ C60/75		5,00									
Partial safety factor	γ _{Mp} = γ _{Mc} ¹⁾	[-]	1,5									
Concrete cone failure												
Product factor k ₁	cracked concrete	k _{cr,N}	[-]	7,2	7,8	7,9		8,1		8,7		
	uncracked concrete	k _{ucr,N}	[-]	10,3	11,2	11,2		11,6		12,4		
Partial safety factor	γ _{Mc} ¹⁾	[-]	1,5									
Splitting												
Characteristic edge distance	C _{cr,sp}	[mm]	135	228	237		282		465			
Partial safety factor	γ _{Msp} = γ _{Mc} ¹⁾	[-]	1,5									

¹⁾ In absence of other national regulations

Table 13: Displacements under tension load

Anchor channel HAC-C			28/15	38/17	40/25	40/22	49/30	50/30	54/33	52/34
Tension load	N	[kN]	3,6	7,1	7,9	13,9	12,3	14,3	21,8	25,8
Short-term displacement ¹⁾	δ _{N0}	[mm]	0,6	1,3	1,4	2,3	1,4	2,2	1,6	1,4
Long-term displacement ¹⁾	δ _{N∞}	[mm]	1,2	2,6	2,8	4,6	2,8	4,4	3,2	2,8

¹⁾ Displacements in midspan of the anchor channel, including slip of channel bolt, deformation of channel lips, bending of the channel and slip of the anchor channel in concrete

Anchor channels (HAC-C) with channel bolts (HBC)

Performance Data

Characteristic resistances of anchor channels and displacements under tension load

Annex C2

Table 14: Characteristic resistances under shear load – steel failure of anchor channel

Anchor channel HAC-C			28/15	38/17	40/25	40/22	49/30	50/30	54/33	52/34
Steel failure: Failure of anchor										
Characteristic resistance	$V_{Rk,s,a}$	[kN]	9,0	18,0	20,0	26,0	31,0	40,3	55,0	71,5
Partial safety factor	$\gamma_{Ms}^{1)}$	[-]	1,5							
Steel failure: Failure of connection between anchor and channel										
Characteristic resistance	$V_{Rk,s,c}$	[kN]	9,0	18,0	20,0	26,0	31,0	40,3	55,0	71,5
Partial safety factor	$\gamma_{Ms,ca}^{1)}$	[-]	1,8							
Steel failure: Local failure by flexure of channel lips										
Characteristic spacing of channel bolts for $V_{Rk,s,l}$	$s_{l,v}$	[mm]	56	76	80	79	100	98	107	105
Characteristic resistance	$V_{Rk,s,l}^0$	[kN]	9,0	18,0	20,0	26,0	31,0	40,3	55,0	71,5
Partial safety factor	$\gamma_{Ms,l}^{1)}$	[-]	1,8							

¹⁾ In absence of other national regulations

Anchor channels (HAC-C) with channel bolts (HBC)

Performance Data

Characteristic resistances of anchor channels under shear load

Annex C3

Table 15: Characteristic resistances under shear load – concrete failure

Anchor channel HAC-C			28/15	38/17	40/25	40/22	49/30	50/30	54/33	52/34
Pry out failure										
Product factor	k_8	[-]	1,0	2,0						
Partial safety factor	$\gamma_{Mc}^{1)}$	[-]	1,5							
Concrete edge failure										
Product factor k_{12}	cracked concrete	$k_{cr,V}$	[-]	6,9	7,5					
	uncracked concrete	$k_{ucr,V}$	[-]	9,6	10,5					
Partial safety factor	$\gamma_{Mc}^{1)}$	[-]	1,5							

¹⁾ In absence of other national regulations

Table 16: Displacements under shear load

Anchor channel HAC-C			28/15	38/17	40/25	40/22	49/30	50/30	54/33	52/34
Shear load	V	[kN]	3,6	7,1	7,9	10,3	12,3	16,0	21,8	28,4
Short-term displacement ¹⁾	δ_{V0}	[mm]	0,6	1,3	1,4	2,1	1,4	2,6	1,6	3,7
Long-term displacement ¹⁾	$\delta_{V\infty}$	[mm]	0,9	2,0	2,1	3,1	2,1	3,9	2,4	5,5

¹⁾ Displacements in midspan of the anchor channel, including slip of channel bolt, deformation of channel lips and slip of the anchor channel in concrete

Table 17: Characteristic resistances under combined tension and shear load

Anchor channel HAC-C			28/15	38/17	40/25	40/22	49/30	50/30	54/33	52/34
Steel failure: Local failure by flexure of channel lips and failure by flexure of channel										
Product factor	k_{13}	[-]	1,0 ¹⁾							
Steel failure: Failure of anchor and connection between anchor and channel										
Product factor	k_{14}	[-]	1,0 ²⁾							

¹⁾ k_{13} can be taken as 2,0 if $V_{Rd,s,l}$ is limited to $N_{Rd,s,l}$

²⁾ k_{14} can be taken as 2,0 if $\max(V_{Rd,s,a}; V_{Rd,s,c})$ is limited to $\min(N_{Rd,s,a}; N_{Rd,s,c})$

Anchor channels (HAC-C) with channel bolts (HBC)

Performance Data

Characteristic resistances of anchor channels and displacements under shear load
Characteristic resistances under combined tension and shear load

Annex C4

Table 18: Characteristic resistances under tension and shear load – steel failure of channel bolts

Channel bolt					M8	M10	M12	M16	M20			
Steel failure												
Characteristic tension resistance	$N_{Rk,s}^{1)}$	[kN]	HBC-28/15	4.6	-							
				8.8	22,4	35,4	44,3	-				
				A4-50 ²⁾	17,2	-						
			HBC-38/17	A4-70 ²⁾	25,6	38,9	51,3	-				
				4.6	-		23,2	-				
				8.8	-		-	35,4	55,8	-		
			HBC-40/22	A4-70 ²⁾	20,5	47,2	53,0	-				
				4.6	-		23,2	-				
				8.8	-		-	35,4	55,8	-		
			HBC-50/30	A4-70 ²⁾	20,5	58,6	91,0	-				
				4.6	-		-					
				8.8	-		-	35,4	55,8	183,1		
			Partial safety factor	$\gamma_{Ms}^{3)}$	[-]	HBC-28/15	4.6	2,00				
						HBC-38/17	8.8	1,50				
						HBC-40/22	A4-50 ²⁾	2,86				
HBC-50/30	A4-70 ²⁾	1,87										
Characteristic shear resistance	$V_{Rk,s}^{1)}$	[kN]	HBC-28/15	4.6	-							
				8.8	14,6	23,2	33,7	-				
				A4-50 ²⁾	11,0	-						
			HBC-38/17	A4-70	15,4	24,4	35,4	-				
				4.6	-		13,9	-				
				8.8	-		-	33,7	62,8	-		
			HBC-40/22	A4-70 ²⁾	24,4	35,4	65,9	-				
				4.6	-		13,9	-				
				8.8	-		-	33,7	62,8	-		
			HBC-50/30	A4-70 ²⁾	24,4	35,4	65,9	-				
				4.6	-		-					
				8.8	-		-	33,7	62,8	98,0		
Partial safety factor	$\gamma_{Ms}^{3)}$	[-]	HBC-28/15	4.6	1,67							
			HBC-38/17	8.8	1,25							
			HBC-40/22	A4-50 ²⁾	2,38							
			HBC-50/30	A4-70	1,56							

¹⁾ In conformity to EN ISO 898-1:1999

²⁾ Materials according to Table 6, Annex A6

³⁾ In absence of other national regulations

Anchor channels (HAC-C) with channel bolts (HBC)

Performance Data

Characteristic resistances of channel bolts under tension and shear load

Annex C5

Table 19: Characteristic resistances under shear load with lever arm – steel failure of channel bolts

Channel bolt ¹⁾				M8	M10	M12	M16	M20		
Steel failure										
Characteristic flexural resistance	$M^{0}_{Rk,s}$	[Nm]	HBC-28/15	4.6	-	29,9 ³⁾	-			
			HBC-38/17	8.8	30,0	59,8	104,8	266,4	519,3	
			HBC-40/22	A4-50 ²⁾	18,7	-				
			HBC-50/30	A4-70 ²⁾	26,2	52,3	91,7	233,1	454,4	
Partial safety factor	γ_{Ms} ¹⁾	[-]	HBC-28/15	4.6	1,67					
			HBC-38/17	8.8	1,25					
			HBC-40/22	A4-50 ²⁾	2,38					
			HBC-50/30	A4-70 ²⁾	1,56					
Internal lever arm	a	[mm]	HBC-28/15	28/15	17,3	18,7	20,0	-		
			HBC-38/17	38/17	-	23,0	24,3	26,3	-	
			HBC-40/22	40/22		24,3	25,7	27,3		
			HBC-50/30	50/30	-	-	29,9	31,7	33,9	

1) In absence of other national regulations

2) Materials according to Table 6, Annex A6

3) Not applicable for HBC-28/15 and HBC-50/30

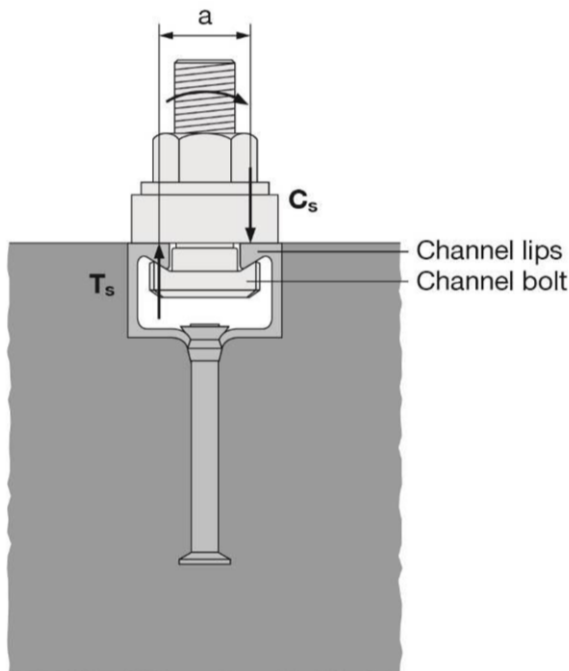

3) The characteristic flexure resistance according to Table 19 is limited as follows:

$$M^{0}_{Rk,s} \leq 0,5 \cdot N_{Rk,s,l} \cdot a \quad (N_{Rk,s,l} \text{ according to Table 10})$$

$$M^{0}_{Rk,s} \leq 0,5 \cdot N_{Rk,s} \cdot a \quad (N_{Rk,s} \text{ according to Table 18})$$

a = internal lever arm according to Table 19

T_s = tension force acting on the channel lips

C_s = compression force acting on the channel lips

Anchor channels (HAC-C) with channel bolts (HBC)

Performance Data

Characteristic flexural resistances of channel bolts under shear load

Annex C6

Table 20: Characteristic resistance $F_{Rd,s,fi}$ [kN] of anchor channels under fire exposure

Channel bolt				M10	M12	≥ M16			
Steel failure of anchor, connection between anchor and channel, local flexure of channel lip									
Characteristic resistance in cracked concrete C20/25	HAC-C 28/15	R60	$N_{Rk,s,fi}$ = $V_{Rk,s,fi}$	[kN]	0,8		-		
		R90			0,6				
		R120			0,5				
	HAC-C 38/17	R60			-		1,9		
		R90			-		1,3		
		R120			-		1,0		
	HAC-C 40/25 HAC-C 40/22	R60			1,7	3,5			
		R90			1,2	2,2			
		R120			0,9	1,5			
	HAC-C 49/30 HAC-C 50/30 HAC-C 52/34	R60			-	3,8	3,9		
		R90			-	2,5	2,9		
		R120			-	1,9	2,4		
	Partial safety factor				$\gamma_{Ms,fi}$ ¹⁾	[-]	1,0		

¹⁾ In absence of other national regulations

Table 21: Minimum concrete cover

Anchor channel HAC-C				28/15	38/17	40/25	40/22	49/30	50/30	54/33	52/34
Concrete cover	R60	u	[mm]	35				50	50	50	50
	R90			45							
	R120			55							

Fire exposure from one side only

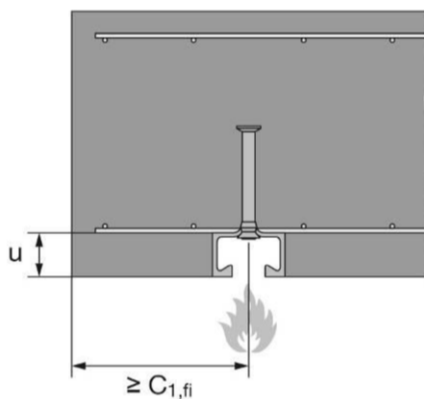

Fire exposure from more than one side

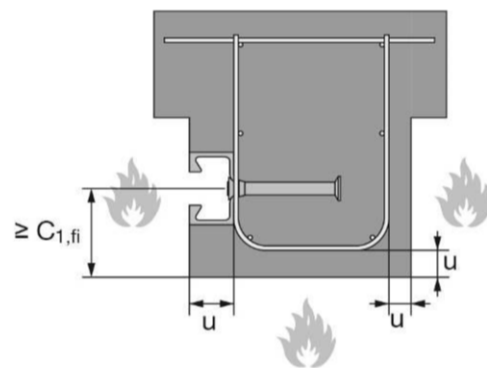

Anchor channels (HAC-C) with channel bolts (HBC)

Performance Data

Characteristic resistances of anchor channels and channel bolts under fire exposure

Annex C7