



Austrian Institute of Construction Engineering
 Schenkenstrasse 4 | T+43 1 533 65 50
 1010 Vienna | Austria | F+43 1 533 64 23
 www.oib.or.at | mail@oib.or.at



European Technical Assessment

ETA-14/0085
 of 29.12.2020

General part

Technical Assessment Body issuing the European Technical Assessment

Österreichisches Institut für Bautechnik (OIB)
 Austrian Institute of Construction Engineering

Trade name of the construction product

Hilti Firestop Collar Endless CFS-C EL

Product family to which the construction product belongs

Fire Stopping and Fire Sealing Products:
 Penetration Seals

Manufacturer

Hilti AG
 Feldkircherstrasse 100
 9494 Schaan
 LIECHTENSTEIN

Manufacturing plant

HILTI production plant 5B

This European Technical Assessment contains

176 pages including Annexes 1 to 5 which form an integral part of this assessment

This European Technical Assessment is issued in accordance with Regulation (EU) No 305/2011, on the basis of

European Assessment Document
 EAD 350454-00-1104 "Fire stopping and fire sealing products – Penetration seals"

This European Technical Assessment replaces

European Technical Assessment ETA-14/0085 of 28.12.2015

8	ANNEX 3:	17
RESISTANCE TO FIRE CLASSIFICATION OF PENETRATION SEALS MADE OF HILTI FIRESTOP		
	COLLAR ENDLESS CFS-C EL	17
8.1	Intended use of pipes and reference to relevant section	17
8.2	General Information Hilti Firestop Collar Endless CFS-C EL	27
8.2.1	Penetration seal	27
8.2.2	Pipe Group/Application Group	27
8.2.3	Collar fixing	28
8.2.4	Required number of fixing hooks	29
8.2.5	Pipe support construction	30
8.2.6	Sound decoupling insulation	30
8.2.7	Utilization of small intumescent sections (oddments)	30
8.2.8	Pipe orientation	31
8.2.9	Distance between penetrations	32
8.2.10	Mineral wool	33
8.2.11	Metal pipes	34
8.2.12	Elastomeric combustible insulation	35
8.2.13	PE based foamed thermal pipe insulation	35
8.2.14	Hilti Firestop Double Board Seal	35
8.2.15	Non-regulated acoustic PP-pipes	36
8.3	Flexible walls	37
8.3.1	Specific characteristics for Flexible walls ($t_E \geq 100$ mm)	37
8.3.2	Penetrating services in 100 mm flexible wall	38
8.4	Rigid walls	70
8.4.1	Specific characteristics for Rigid walls ($t_E \geq 100$ mm)	70
8.4.2	Penetration services rigid walls ($t_E \geq 100$ mm)	71
8.5	Rigid floor	96
8.5.1	Specific characteristics for Rigid floor ($t_E \geq 150$ mm)	96
8.5.2	Penetration services in rigid floor ($t_E \geq 150$ mm)	97
8.6	Shaft walls	144
8.6.1	Specific characteristics for Shaft walls	144
8.6.2	Penetration service in shaft walls system A: 2 x 25 mm (refer to 8.6.1.1)	147
8.6.3	Penetration service in shaft walls system B: 3 x 15 mm (refer to 8.6.1.2)	151
9	ANNEX 4: ABBREVIATIONS AND REFERENCE DOCUMENTS	173
10	ANNEX 5: INSTRUCTION FOR USE	175

Specific parts

1 Technical description of the product

“Hilti Firestop Collar Endless CFS-C EL” is a pipe collar to be used as pipe penetration seal.

Type of penetration seal system: Pipe closure device – collar (see EAD 350454-00-1104, clause 1.1). “Hilti Firestop Collar Endless CFS-C EL” consists of an intumescent strip with a soft PUR foam strip, metallic closure plates and fastening hooks (long and short version), made of stainless steel.

“Hilti Firestop Collar Endless CFS-C EL” is supplied in one size only. The collar is cut to a length to suit the overall circumference of pipe or pipe and insulation and equipped with closing plates, then installed underneath floors or on both sides of a wall and fixed by hooks and metal anchors/screws or threaded rods with washers and nuts.

Ancillary products referred to in this European Technical Assessment within the framework of evaluating resistance to fire (see Annex 2 and 3 of the ETA) are not covered by this European Technical Assessment and cannot be CE-marked based on it.

For a description of the installation procedure see Annex 5 of the ETA.

2 Specification of the intended use(s) in accordance with the applicable European Assessment Document (hereinafter EAD)

2.1 Intended use

“Hilti Firestop Collar Endless CFS-C EL” is intended to form a penetration seal or to form parts of a penetration seal, which is used to maintain the fire resistance of a separating element (flexible wall, shaft wall, rigid wall or rigid floor) when and where services pass through.

The pipe penetration seal is intended for plastic pipes in piping systems for waste water, non-combustible liquids and fluids, for pneumatic dispatch systems and for pipes in centralized vacuum-cleaning systems.

“Hilti Firestop Collar Endless CFS-C EL” may be used to provide a penetration seal with plastic pipes as mainly single penetrations. For details on diameters, wall thicknesses, pipe materials and pipe standards see Annex 3 of the ETA, which gives details of penetration seals for which fire resistance was assessed. Pipes have to be installed mainly perpendicular to the seal surface. Deviant situations are described in detail in Annex 3 of the ETA. This European Technical Assessment covers only assemblies installed in accordance with the provisions given in Annex 2 and 3 of the ETA.

For the purpose of smoke and draft stop, air or water tightness and airborne sound insulation, the gap between opening edge and pipe/pipe insulation has to be sealed off by gypsum plaster, cementious mortar or a construction sealant, the latter optionally in combination with mineral wool as backfilling material, considering the detailed prescriptions given in Annex 2 and 3 of the ETA.

Sound decoupling can be provided either by using “Hilti Firestop Acrylic Sealant CFS-S ACR” (ETA-10/0292) as annular gap seal or by using gypsum plaster or cementious mortar along with PE foam or a polyester based sound decoupling material. For details see Annex 2 and 3 of the ETA.

2.2 Use condition

“Hilti Firestop Collar Endless CFS-C EL” is intended for use at temperatures below 0 °C, but with no exposure to rain nor UV, and can therefore – according to EAD 350454-00-1104, clause 2.2.9.3.1 – be categorized as Type Y₂. Since the requirements for Type Y₂ are met, also the requirements for Type Z₁ and Z₂ are fulfilled.

Although a penetration seal is intended for indoor applications only, the construction process may result in it being subjected to more exposed conditions for a period before the building envelope is closed. For this case provisions shall be made to protect temporarily exposed penetration seals according to the ETA-holder’s installation instructions.

2.3 Working life

The provisions made in this European Technical Assessment are based on an assumed working life of “Hilti Firestop Collar Endless CFS-C EL” of 10 years, provided the conditions laid down in the technical literature of the manufacturer relating to packaging, transport, storage, installation, use and repair are met.

The indications given on the intended working life cannot be interpreted as a guarantee given by the producer or the Technical Assessment Body, but are to be regarded only as a means for selecting the appropriate product in relation to the expected economically reasonable working life of the works.

The real working life might be, in normal use conditions, considerably longer without major degradation affecting the basic requirements for construction works.

2.4 General assumptions

2.4.1 It is assumed that

- > damages to the penetration seal are repaired accordingly,
- > the installation of the penetration seal does not effect the stability of the adjacent building element – even in case of fire,
- > the lintel or floor above the penetration seal is designed structurally and in terms of fire protection such that no additional mechanical load (other than its own weight) is imposed on the penetration seal,
- > the thermal movement in the pipe work will be accommodated in such way that it does not impose a load on the penetration seal,
- > the installations are fixed to the adjacent building element in accordance with the relevant regulations in such a way that, in case of fire, no additional mechanical load is imposed to the penetration seal,
- > the support of the installations is maintained for the required period of fire resistance and
- > pneumatic dispatch systems, compressed air systems, etc. are switched off by additional means in case of fire.

2.4.2 This European Technical Assessment does not address any risks associated with the emission of dangerous liquids or gases caused by failure of the pipe(s) in case of fire nor does it prove the prevention of the transmission of fire through heat transfer via the medium in the pipes.

2.4.3 This European Technical Assessment does not verify the prevention of destruction of adjacent building elements with fire separating function or of the pipes themselves due to distortion forces caused by extreme temperatures. These risks shall be accounted for by taking appropriate measures when designing or installing the pipe work.

The mounting or hanging of the pipes or the layout of the pipe work shall be implemented in such a way that the pipes and the fire resistant building elements shall remain functional within a period of time which corresponds to the fire resistance period required.

- 2.4.4 The risk of downward spread of fire caused by burning material which drips through a pipe to floors below, is not considered in this European Technical Assessment (see EN 1366-3:2009, clause 1).
- 2.4.5 The durability assessment does not take account of the possible effect on the penetration seal of substances permeating through the pipe walls.
- 2.4.6 The assessment does not cover the avoidance of destruction of the penetration seal or of the adjacent building element(s) by forces caused by temperature changes in case of fire. This has to be considered when designing the piping system.

2.5 **Manufacturing**

The European Technical Assessment is issued for the product on the basis of agreed data/information, deposited with the Österreichisches Institut für Bautechnik, which identifies the product that has been assessed and judged. Changes to the product or production process, which could result in this deposited data/information being incorrect, should be notified to the Österreichisches Institut für Bautechnik before the changes are introduced.

The Österreichisches Institut für Bautechnik will decide whether or not such changes affect the European Technical Assessment and consequently the validity of the CE marking on the basis of the European Technical Assessment and if so whether further Assessment or alterations to the European Technical Assessment, shall be necessary.

electronic copy electronic copy electronic copy electronic copy electronic copy electronic copy electronic copy

3 Performance of the product and references to the methods used for its Assessment

Basic requirements for construction works	Essential characteristic	Method of verification	Performance
BWR 2	Reaction to fire	EN 13501-1	Clause 3.1.1 of the ETA
	Resistance to fire	EN 13501-2	Clause 3.1.2 of the ETA and Annex 3 of the ETA
BWR 3	Air permeability (material property)	EN 1026	Clause 3.2.1 of the ETA
	Water permeability (material property)	EAD 350454-00-1104 Annex C	Clause 3.2.2 of the ETA
	Content, emission and/or release of dangerous substances	EN 16516	Clause 3.2.3 of the ETA
BWR 4	Mechanical resistance and stability	No performance assessed	
	Resistance to impact / movement	No performance assessed	
	Adhesion	No performance assessed	
	Durability	EOTA TR 024	Clause 3.3.4 of the ETA
BWR 5	Airborne sound insulation	EN ISO 140-10, EN ISO 10140-1, EN ISO 10140-2 and EN ISO 717-1	Clause 3.4.1 of the ETA
BWR 6	Thermal properties	No performance assessed	
	Water vapour permeability	No performance assessed	

3.1 Safety in case of fire (BWR 2)

3.1.1 Reaction to fire

The components of “Hilti Firestop Collar Endless CFS-C EL” were assessed according to EAD 350454-00-1104, clause 2.2.1 and classified according to EN 13501-1.

The reaction to fire classification for the inlay of “Hilti Firestop Collar Endless CFS-C EL” is class “E” according to EN 13501-1. (Other components are made of stainless steel with reaction to fire class “A1” according to Commission Decision 96/603/EC¹).

The reaction to fire classification for “Hilti Firestop Acrylic Sealant CFS-S ACR” is class “D-s1 d0” according to EN 13501-1.

The reaction to fire classification for “Hilti Firestop Mastic Filler CFS-FIL” is class “E” according to EN 13501-1.

The reaction to fire classification for “Hilti Fire Stop Coating CFS-CT” is class “D-s2 d0” according to EN 13501-1.

¹ Official Journal of the European Communities no. L 267, 19.10.1996, p. 23

3.1.2 Resistance to fire

The resistance to fire classification according to EN 13501-2 of penetration seals made of “Hilti Firestop Collar Endless CFS-C EL” is given in Annex 3 of the ETA.

Information on ancillary products, which were tested within the framework of this European Technical Assessment for assessing resistance to fire is given in Annex 2 of the ETA.

3.2 Hygiene, health and the environment (BWR 3)

3.2.1 Air permeability

Air tightness for a single penetration of a plastic pipe, equipped with “Hilti Firestop Collar Endless CFS-C EL” can only be achieved when the annular gap is sealed with a sealant, e.g. “Hilti Firestop Acrylic Sealant CFS-S ACR” or “Hilti Firestop Mastic Filler CFS-FIL”.

For “Hilti Firestop Acrylic Sealant CFS-S ACR” and “Hilti Firestop Mastic Filler CFS-FIL” the gas permeability regarding the gases air, nitrogen (N₂), carbon dioxide (CO₂) and CH₄ (methane) has been tested according to the principles of EN 1026.

The “Hilti Firestop Acrylic Sealant CFS-S ACR” was installed in a thickness of 10 mm.

The “Hilti Firestop Mastic Filler CFS-FIL” was installed in a thickness of 50 mm.

The “Hilti Firestop Coating CFS-CT” was tested on a pre-coated board “Hilti Firestop Board CFS-CT B 1S”. Two pre-coated board samples (each of 50 mm mineral wool coated with a dry film thickness of 1 to 2 mm) were put together and gas flow was determined.

The non-tested air flow rate for “Hilti Firestop Mastic Filler CFS-FIL” and “Hilti Firestop Coating CFS-CT” will be similar to the nitrogen flow rate, as air consists of nearly 80 % of tested nitrogen.

For annular gaps sealed with cementitious mortar or gypsum plaster no performance has been assessed.

The following flow rates per area (q/A) have been achieved for the given air pressure differences (Δp). The flow rate index indicates the type of gas:

Product	Δp [Pa]	q/A air [m ³ /(h*m ²)]	q/A N ₂ [m ³ /(h*m ²)]	q/A CO ₂ [m ³ /(h*m ²)]	q/A CH ₄ [m ³ /(h*m ²)]
CFS-S ACR	50	≤ 1,9E-06	≤ 1,1E-06	≤ 6,4E-05	≤ 4,3E-05
	250	≤ 9,7E-06	≤ 5,5E-06	≤ 3,2E-04	≤ 2,1E-04
CFS-FIL	50	Not tested	< 1 E-06	< 1 E-06	< 1 E-06
	250	Not tested	< 1 E-06	< 1 E-06	< 1 E-06
CFS-CT / CFS-CT B 1S/2S	50	Not tested	≤ 3,2 E-02	≤ 6,0 E-02	≤ 6,5 E-02
	250	Not tested	≤ 1,6 E-01	≤ 3,0 E-01	≤ 3,3 E-01

The values refer to a body of pure “Hilti Firestop Acrylic Sealant CFS-S ACR”, “Hilti Firestop Mastic Filler CFS-FIL”, “Hilti Firestop Coating CFS-CT” / “Hilti Firestop Board CFS-CT B 1S” / “Hilti Firestop Board CFS-CT B 2S” without any penetrating installation.

3.2.2 Water permeability

Water tightness for a single penetration of a plastic pipe, equipped with “Hilti Firestop Collar Endless CFS-C EL” can only be achieved when the annular gap is sealed with a sealant, e.g. “Hilti Firestop Acrylic Sealant CFS-S ACR”, “Hilti Firestop Mastic CFS-FIL” or “Hilti Firestop Coating CFS-CT” / “Hilti Firestop Board CFS-CT B 1S” / “Hilti Firestop Board CFS-CT B 2S”.

The water permeability of “Hilti Firestop Acrylic Sealant CFS-S ACR”, “Hilti Firestop Mastic Filler CFS-FIL”, “Hilti Firestop Coating CFS-CT” / “Hilti Firestop Board CFS-CT B 1S” / “Hilti

Firestop Board CFS-CT B 2S" has been tested according to the principles given in Annex C of EAD 350454-00-1104. The specimen consisted of 2 mm "Hilti Firestop Acrylic Sealant CFS-S ACR" and "Hilti Firestop Mastic Filler CFS-FIL" (dry film thickness) on mineral wool. "Hilti Firestop Coating CFS-CT" was tested as a 0,7mm thick coating dry film on mineral wool board.

Test result: water tight to 1000 mm head of water or 9806 Pa.

For annular gaps sealed with cementitious mortar or gypsum plaster no performance has been assessed.

3.2.3 Content, emission and/or release of dangerous substances

"Hilti Firestop Collar Endless CFS-C EL" was tested for SVOC and VOC according EAD 350454-00-1104, clause 2.2.5.1, in accordance with EN 16516 with a loading factor of 0,007 m²/m³. Release scenario IA1 and IA2 have been tested.

The concentration of SVOC after 3 days and after 28 days was < 0,005 mg/m³. The concentration of the total emission of VOC after 3 days and after 28 days was, as well, < 0,005 mg/m³.

3.3 Safety and accessibility in use (BWR 4)

3.3.1 Mechanical resistance and stability

No performance assessed.

3.3.2 Resistance to impact / movement

No performance assessed.

3.3.3 Adhesion

No performance assessed

3.3.4 Durability

"Hilti Firestop Collar Endless CFS-C EL" is intended for use at temperatures below 0 °C, but with no exposure to rain nor UV, and can therefore – according to EAD 350454-00-1104, clause 2.2.9.3.1 – be categorized as Type Y₂.

3.4 Protection against noise (BWR 5)

3.4.1 Airborne sound insulation

Airborne sound insulation for a single penetration of a plastic pipe, equipped with "Hilti Firestop Collar Endless CFS-C EL" can only be achieved when the annular gap is sealed "Hilti Firestop Acrylic Sealant CFS-S ACR". It has to be noted that the values given in in this clause are only valid if the annular gap is sealed using stone wool as backfilling material (which is not necessary in all cases for fire resistance – see Annex 3 of the ETA).

The acoustic characteristics of the walls itself have not been measured. According to the test results the single number ratings are:

Flexible wall:

Weighted element-normalized level difference:

$$D_{n,e,w}(C, C_{tr}) = 68 \text{ (-2;-6) dB (scenario 1)}$$

$$D_{n,e,w}(C, C_{tr}) = 64 \text{ (-3;-) dB (scenario 2)}$$

From this $D_{n,e,w}$ the weighted sound reduction index calculates to:

$$R_w(C; C_{tr}) = 61 \text{ (-3;-6) dB (scenario 1)}$$

$$R_w R(C; C_{tr}) = 56 \text{ (-2;-2) dB (scenario 2)}$$

It should be noticed that both above mentioned results apply to the total wall construction of the size $S = 1,25 \text{ m} \times 1,50 \text{ m} (= 1,88 \text{ m}^2)$

$D_{n,e,w}$ = weighted element-normalized level difference of small building elements (given with spectrum adaptation terms C and C_{tr})

R_w = weighted sound reduction index (given with spectrum adaptation terms C and C_{tr})

3.5 Energy economy and heat retention (BWR 6)

3.5.1 Thermal properties

No performance assessed.

3.5.2 Water vapour permeability

No performance assessed.

4 Assessment and verification of constancy of performance (hereinafter AVCP) system applied, with reference to its legal base

4.1 AVCP system

According to the Decision 1999/454/EC², amended by Decision 2001/596/EC³ of the European Commission the system(s) of assessment and verification of constancy of performance (see Annex V of Regulation (EU) No 305/2011) is given in the following table.

Product(s)	Intended use(s)	Level(s) or class(es) (resistance to fire)	System of assessment and verification of constancy of performance
Fire Stopping and Fire Sealing Products	for fire compartmentation and/or fire protection or fire performance	any	1

In addition, according to the Decision 1999/454/EC, amended by Decision 2001/596/EC of the European Commission the system(s) of assessment and verification of constancy of performance, with regard to reaction to fire, is given in the following table.

Product(s)	Intended use(s)	Level(s) or class(es) (reaction to fire)	System of assessment and verification of constancy of performance
Fire Stopping and Fire Sealing Products	For uses subject to regulations on reaction to fire	A1*, A2*, B*, C*	1
		A1**, A2**, B**, C**, D, E	3
		(A1 to E)***, F	4
<p>* Products/materials for which a clearly identifiable stage in the production process results in an improvement of the reaction to fire classification (e.g. an addition of fire retardants or a limiting of organic material)</p> <p>** Products/materials not covered by footnote (*)</p> <p>*** Products/materials that do not require to be tested for reaction to fire (e.g. products/materials of class A1 according to Commission Decision 96/603/EC, as amended)</p>			

² Official Journal of the European Communities no. L 178, 14.7.1999, p. 52

³ Official Journal of the European Communities no. L 209, 2.8.2001, p. 33

5 Technical details necessary for the implementation of the AVCP system, as provided for the applicable European Assessment Document

Technical details necessary for the implementation of the AVCP system are laid down in the control plan deposited with the Technical Assessment Body Österreichisches Institut für Bautechnik.

The notified product certification body shall visit the factory at least twice a year for surveillance of the manufacturer.

Issued in Vienna on 29.12.2020
by Österreichisches Institut für Bautechnik

The original document is signed by:

Rainer Mikulits
Managing Director

electronic copy
electronic copy
electronic copy
electronic copy
electronic copy
electronic copy
electronic copy

6 ANNEX 1: REFERENCE DOCUMENTS

6.1 Standards mentioned in this ETA

EN 1026	Windows and doors – Air permeability – Test method
EN 1329-1	Plastics piping systems for soil and waste discharge (low and high temperature) within the building structure - Unplasticized poly(vinyl chloride) (PVC-U)
EN 1366-3:2009	Fire resistance tests for service installations - Part 3: Penetration seals
EN 1451-1	Plastics piping systems for soil and waste discharge (low and high temperature) within the building structure - Polypropylene (PP) – Part 1: Specifications for pipes, fittings and the system
EN 1453-1	Plastics piping systems with structured-wall pipes for soil and waste discharge (low and high temperature) inside buildings - Unplasticized poly(vinyl chloride) (PVC-U)
EN 1519-1	Plastics piping systems for soil and waste discharge (low and high temperature) within the building structure - Polyethylene (PE) - Part 1: Specifications for pipes, fittings and the system
EN 1566-1	Plastics piping systems for soil and waste discharge (low and high temperature) within the building structure - Chlorinated poly(vinyl chloride) (PVC-C) - Part 1: Specifications for pipes, fittings and the system
EN 12201-2	Plastics piping systems for water supply, and for drainage and sewerage under pressure - Polyethylene (PE) - Part 2: Pipes
EN 12666-1	Plastics piping systems for non-pressure underground drainage and sewerage – Polyethylene (PE) – Part 1: Specifications for pipes, fittings and the system
EN 13501	Fire classification of construction products and building elements – Part 1: Classification using test data from reaction to fire tests Part 2: Classification using test data from fire resistance tests, excluding ventilation services
EN ISO 140-3	Acoustics – Measurement of sound insulation in buildings and of building elements – Part 3: Laboratory measurements of airborne sound insulation of building elements ⁴
EN ISO 717-1	Acoustics – Rating of sound insulation of buildings and of building elements – Part 1: Airborne sound insulation
EN ISO 1519	Paints and varnishes – Bend test (cylindrical mandrel)
EN ISO 1452	Plastics piping systems for water supply and for buried and above-ground drainage and sewerage under pressure - Unplasticized poly(vinyl chloride) (PVC-U) ⁵
EN ISO 15493	Plastics piping systems for industrial applications - Acrylonitrile-butadiene-styrene (ABS), unplasticized poly(vinyl chloride) (PVC-U) and chlorinated poly(vinyl chloride) (PVC-C) - Specifications for components and the system; Metric series
EN ISO 15494	Plastics piping systems for industrial applications - Polybutene (PB), polyethylene (PE) and polypropylene (PP) - Specifications for components and the system; Metric series
EN ISO 15874	Plastics piping systems for hot and cold water installations - Polypropylene (PP)
EN ISO 20140-10	Acoustics – Measurements of sound insulation in buildings and of building elements – Part 10: Laboratory measurement of airborne sound insulation of small building elements
EN 998-2:2003	Specification for mortar used for masonry – Part 2
DIN 8061	Unplasticized polyvinyl chloride (PVC-U) pipes - General quality requirements and testing
DIN 8062	Unplasticized polyvinyl chloride (PVC-U) pipes - Dimensions

⁴ In September 2010 substituted by the EN ISO 10140 series

⁵ Successor of EN 1452 since December 2009

DIN 8074	Polyethylene (PE) - Pipes PE 80, PE 100 - Dimensions
DIN 8075	Polyethylene (PE) pipes - PE 80, PE 100 - General quality requirements, testing
DIN 8077	Polypropylene (PP) pipes - PP-H, PP-B, PP-R, PP-RCT – Dimensions
DIN 8078	Polypropylene (PP) pipes - PP-H, PP-B, PP-R, PP-RCT - General quality requirements and testing
DIN 19531-10	Pipes and fittings made of unplasticized polyvinyl chloride (PVC-U) socket for waste and soil discharge systems inside buildings – Part 10: Fire behaviour, quality control and installation recommendations
DIN 19535-10	High-density polyethylene (PE-HD) pipes and fittings for hot-water resistant waste and soil discharge systems (HT) inside buildings – Part 10: Fire behaviour, quality control and installation recommendations

6.2 Other reference documents

EOTA TR 001	Determination of impact resistance of panels and panel assemblies
EOTA TR 024	Characterisation, Aspects of Durability and Factory Production Control for Reactive Materials, Components and Products

7 ANNEX 2: DESCRIPTION OF PRODUCT(S) & PRODUCT LITERATURE

7.1 Hilti Firestop Collar Endless CFS-C EL

The inlay of the collar consists of one intumescent strip with a soft polyurethane foam layer as a noise decoupling element. A detailed specification of the product is contained in document "Identification / Product Specification" relating to this European Technical Assessment, which is a non-public part of this ETA.

The Control Plan is defined in document "Control Plan" relating to this European Technical Assessment, which is a non-public part of this ETA.

Technical product literature

- Technical Data Sheet Hilti Firestop Collar Endless CFS-C EL (including the use of ancillary products according to Annex 2 of the ETA).

7.2 Ancillary products

Hilti Firestop Acrylic Sealant CFS-S ACR

A detailed specification of the product is contained in document "Identification / Product Specification relating to ETA-10/0292 and ETA-10/0389 - Hilti Firestop Acrylic Sealant CFS-S ACR", which is a non-public part of the referenced ETAs.

The Control Plan is defined in document "Control Plan relating to ETA-10/0292 and ETA-10/0389 - Hilti Firestop Acrylic Sealant CFS-S ACR" which is a non-public part of the referenced ETAs.

Hilti Firestop Acrylic Sealant CFS-S ACR is available in three several colours (white, grey, red) and in several packaging (cartridges, foil bags and pails).

Gypsum plaster

Any gypsum plaster suitable for use with flexible wall constructions or the intended type of rigid walls or floors may be used.

Cementious mortar

Any cementious mortar according EN 998-2 - class M10 - is suitable for use with the intended type of rigid walls or floors may be used.

Mineral wool

Loose mineral wool products suitable for being used as backfilling material of Hilti Firestop Acrylic Sealant CFS-S ACR

Product	Manufacturer	Specification
Heralan LS	Knauf Insulation GmbH	Product data sheet of Knauf
Isover loose wool SL	Saint-Gobain ISOVER	Product data sheet of Isover
Isover Universal-Stopfwole	Saint-Gobain ISOVER	Product data sheet of Isover
Rockwool RL	Rockwool	Product data sheet of Rockwool
Paroc Pro Loose Wool	Paroc OY AB	Product data sheet of Paroc

- Combustibility class: A1 or A2 in accordance with EN 13501-1

Hilti Firestop Mastic Filler CFS-FIL

The filler is available as a cartridge or as a foil packs.

The Control Plan is defined in document "Control Plan" relating to the European Technical Assessment ETA-13/0099 – Hilti Firestop Mastic Filler CFS-FIL", which is a non-public part of this ETA.

Suitable dispensers:

- Hilti CFS-DISP / CS 201-P1 (for cartridge)
- Hilti CS 270-P1 (for foil pack)

Hilti Fire Stop Coating CFS-CT

A detailed specification of the product is contained in document "Identification / Product Specification" relating to the European Technical Assessment ETA-11/0429 - Hilti Fire Stop Coating CFS-CT which is a non-public part of the referenced ETAs. Within this ETA a detailed description of the coated fire stop board Hilti CFS-CT B – the applied and dried coating CFS-CT on mineral wool boards. There is a one side coated version (CFS-CT B 1S) and a double side coated version (CFS-CT B 2S) available.

The Control Plan is defined in document "Control Plan" relating to the European Technical Assessment ETA-11/0429 - Hilti Fire Stop Coating CFS-CT" which is a non-public part of the referenced ETAs.

7.3 Technical product literature

The technical product literature is a separated part of this European Technical Assessment.

8 ANNEX 3:

RESISTANCE TO FIRE CLASSIFICATION OF PENETRATION SEALS MADE OF HILTI FIRESTOP COLLAR ENDLESS CFS-C EL

8.1 Intended use of pipes and reference to relevant section

(list not exhaustive, other use of pipes possible)

Pipe Material: PE
Manufacturer, Product / Pipe Standard: EN 1519-1, EN12666-1, EN 12201-2

Application	Shaftwall	Flexible and rigid wall $t_E \geq 100$ mm $\rho_E \geq 650$ kg/m ³ (for rigid wall only)	Rigid wall $t_E \geq 100$ mm $\rho_E \geq 650$ kg/m ³	Rigid wall $t_E \geq 150$ mm $\rho_E \geq 650$ kg/m ³	Rigid floor $t_E \geq 150$ mm $\rho_E \geq 650$ kg/m ³
Waste water	8.6.2.1,	8.3.2.1,	8.3.2.1,	8.3.2.1,	8.5.2.1
	8.6.3.1,	8.3.2.21 (inclined 45°)	8.3.2.21 (inclined 45°)	8.3.2.21 (inclined 45°)	8.5.2.31 (use of oddment)
	8.6.3.7,	8.3.2.22 (collar to Mineral Wool)	8.3.2.22 (collar to Mineral Wool)	8.3.2.22 (collar to Mineral Wool)	8.5.2.32 (hooks in wet mortar)
	8.6.3.9.	8.3.2.23 (collar to CFS-B)	8.3.2.23 (collar to CFS-B)	8.3.2.23 (collar to CFS-B)	8.5.2.33 (inclined pipes 45°)
	8.6.3.11	8.3.2.24 (collar to board)	8.3.2.24 (collar to board)	8.3.24 (collar to board)	8.5.2.36 (pipes in corner)
		8.3.2.25 (collar to collar)	8.3.2.25 (collar to collar)	8.3.2.25 (collar to collar)	8.5.2.37 (pipe on the wall)
			8.4.2.1	8.4.2.1	8.5.2.39 (collar to collar PG1)
			8.4.2.8 (pipe on the wall)	8.4.2.8 (pipe on the wall)	8.5.2.40 (collar to collar PG2)
			8.4.2.11 (roof drainage)	8.4.2.11 (roof drainage)	8.5.2.41 (collar to Mineral Wool)
			8.4.2.14 (use of oddment)	8.4.2.14 (use of oddment)	8.5.2.42 (collar to CFS-B)
			8.4.2.15 (hooks in mortar)	8.4.2.15 (hooks in mortar)	8.5.2.43 (collar to board)
			8.4.2.19 (pipes in corner)	8.4.2.19 (pipes in corner)	8.5.2.44 (roof drainage)
				8.4.2.20	8.5.2.45 (pipe junction / manifold)
				8.4.2.32 (collar to collar)	

Pipe Material: PE
Manufacturer, Product / Pipe Standard: Geberit Silent dB 20 (non-regulated by EN standards)

Application	Shaftwall	Flexible and rigid wall $t_E \geq 100 \text{ mm}$ $\rho_E \geq 650 \text{ kg/m}^3$ (for rigid wall only)	Rigid wall $t_E \geq 100 \text{ mm}$ $\rho_E \geq 650 \text{ kg/m}^3$	Rigid wall $t_E \geq 150 \text{ mm}$ $\rho_E \geq 650 \text{ kg/m}^3$	Rigid floor $t_E \geq 150 \text{ mm}$ $\rho_E \geq 650 \text{ kg/m}^3$
Waste water	8.6.2.6,	8.3.2.12,	8.3.2.12,	8.3.2.12,	8.5.2.10
	8.6.3.3,	8.3.2.21 (inclined 45°)	8.3.2.21 (inclined 45°)	8.3.2.21 (inclined 45°)	8.5.2.13 (2 x 45° elbow)
	8.6.3.4 (87° elbow),	8.3.2.22 (collar to Mineral Wool)	8.3.2.22 (collar to Mineral Wool)	8.3.2.22 (collar to Mineral Wool)	8.5.2.14 (pipe coupling)
	8.6.3.5 (2 x 45° elbow),	8.3.2.23 (collar to CFS-B)	8.3.2.23 (collar to CFS-B)	8.3.2.23 (collar to CFS-B)	8.5.2.25
	8.6.3.6 (pipe coupling)	8.3.2.24 (collar to board)	8.3.2.24 (collar to board)	8.3.2.24 (collar to board)	8.5.2.31 (use of oddment)
	8.6.3.7 (collar to collar)	8.3.2.25 (collar to collar PG1)	8.3.2.25 (collar to collar PG1)	8.3.2.25 (collar to collar PG1)	8.5.2.32 (hooks in wet mortar)
	8.6.3.9 (Collar to ACP)		8.4.2.8 (pipe on the wall)	8.4.2.8 (pipe on the wall)	8.5.2.33 (inclined pipes 45°)
	8.6.3.11 (Collar to ACP and electric conduits)		8.4.2.11 (roof drainage)	8.4.2.11 (roof drainage)	8.5.2.36 (pipes in corner)
			8.4.2.12 (2x45° elbow)	8.4.2.12 (pipe coupling)	8.5.2.37 (pipe on the wall)
			8.4.2.13 (pipe coupling)	8.4.2.13 (2x45° elbow)	8.5.2.39 (collar to collar PG1)
			8.4.2.14 (use of oddment)	8.4.2.14 (use of oddment)	8.5.2.39 (collar to collar PG2)
			8.4.2.15 (hooks in mortar)	8.4.2.15 (hooks in mortar)	8.5.2.41 (collar to Mineral Wool)
			8.4.2.19 (pipes in corner)	8.4.2.19 (pipes in corner)	8.5.2.42 (collar to CFS-B)
				8.4.2.30	8.5.2.43 (collar to board)
				8.4.2.32 (collar to collar PG2)	8.5.2.44 (roof drainage)
					8.5.2.45 (pipe junction / manifold)

Pipe Material: PE
Manufacturer, Product / Pipe Standard: Wavin W (EN 15494 and EN 12201-2, DIN 8074/75)

Application	Shaftwall	Flexible and rigid wall $t_E \geq 100 \text{ mm}$ $\rho_E \geq 650 \text{ kg/m}^3$ (for rigid wall only)	Rigid wall $t_E \geq 100 \text{ mm}$ $\rho_E \geq 650 \text{ kg/m}^3$	Rigid wall $t_E \geq 150 \text{ mm}$ $\rho_E \geq 650 \text{ kg/m}^3$	Rigid floor $t_E \geq 150 \text{ mm}$ $\rho_E \geq 650 \text{ kg/m}^3$
Industrial	8.6.2.2	8.3.2.4,	8.3.2.4,	8.3.2.4,	8.5.2.3
		8.3.2.5,	8.3.2.5,	8.3.2.5,	8.5.2.18
		8.3.2.6,	8.3.2.6,	8.3.2.6,	8.5.2.19
		8.3.2.7	8.3.2.7,	8.3.2.7,	8.5.2.20
		8.3.2.21 (inclined 45°)	8.3.2.21 (inclined 45°),	8.3.2.21 (inclined 45°)	8.5.2.31 (use of oddment)
		8.3.2.22 (collar to Mineral Wool)	8.3.2.22 (collar to Mineral Wool)	8.3.2.22 (collar to Mineral Wool)	8.5.2.32 (hooks in wet mortar)
		8.3.2.23 (collar to CFS-B)	8.3.2.23 (collar to CFS-B)	8.3.2.23 (collar to CFS-B)	8.5.2.33 (inclined pipes 45°)
		8.3.2.24 (collar to board)	8.3.2.24 (collar to board)	8.3.2.24 (collar to board)	8.5.2.36 (pipes in corner)
		8.3.2.25 (collar to collar PG1)	8.3.2.25 (collar to collar PG1)	8.3.2.25 (collar to collar PG1)	8.5.2.37 (pipe on the wall)
			8.4.2.2,	8.4.2.2,	8.5.2.39 (collar to collar PG1)
			8.4.2.3	8.4.2.3,	8.5.2.40 (collar to collar PG2)
			8.4.2.8 (pipe on the wall)	8.4.2.8 (pipe on the wall)	8.5.2.41 (collar to Mineral Wool)
			8.4.2.14 (use of oddment)	8.4.2.14 (use of oddment)	8.5.2.42 (collar to CFS-B)
			8.4.2.15 (hooks in mortar)	8.4.2.15 (hooks in mortar)	8.5.2.43 (collar to board)
			8.4.2.16	8.4.2.16	8.5.2.45 (pipe junction / manifold)
			8.4.2.19 (pipes in corner)	8.4.2.19 (pipes in corner)	
				8.4.2.23	
				8.4.2.32 (collar to collar PG2)	

Pipe Material: PP
Manufacturer, Product / Pipe Standard: EN 1451-1 and DIN 8077/78

Application	Shaftwall	Flexible and rigid wall $t_E \geq 100$ mm $\rho_E \geq 650$ kg/m ³ (for rigid wall only)	Rigid wall $t_E \geq 100$ mm $\rho_E \geq 650$ kg/m ³	Rigid wall $t_E \geq 150$ mm $\rho_E \geq 650$ kg/m ³	Rigid floor $t_E \geq 150$ mm $\rho_E \geq 650$ kg/m ³
Waste water	8.6.2.5	8.3.2.10, 8.3.2.11, 8.3.2.21 (inclined 45°) 8.3.2.22 (collar to Mineral Wool) 8.3.2.23 (collar to CFS-B) 8.3.2.24 (collar to board) 8.3.2.25 (collar to collar PG1) 8.3.2.26 (pipe coupling) 8.3.2.28 (Elbow 87°)	8.3.2.10, 8.3.2.11, 8.3.2.21 (inclined 45°) 8.3.2.22 (collar to Mineral Wool) 8.3.2.23 (collar to CFS-B) 8.3.2.24 (collar to board) 8.3.2.25 (collar to collar PG1) 8.3.2.26 (pipe coupling) 8.3.2.28 (Elbow 87°) 8.4.2.6 8.4.2.7 8.4.2.8 (pipe on the wall) 8.4.2.14 (use of oddment) 8.4.2.15 (hooks in mortar) 8.4.2.19 (pipes in corner)	8.3.2.10, 8.3.2.11, 8.3.2.18 (pipe on the wall) 8.3.2.21 (inclined 45°) 8.3.2.22 (collar to Mineral Wool) 8.3.2.23 (collar to CFS-B) 8.3.2.24 (collar to board) 8.3.2.25 (collar to collar PG1) 8.3.2.26 (pipe coupling) 8.3.2.28 (Elbow 87°) 8.4.2.14 (use of oddment) 8.4.2.15 (hooks in mortar) 8.4.2.19 (pipes in corner) 8.4.2.26 8.4.2.27 8.4.2.28 8.4.2.32 (collar to collar PG2) 8.4.2.33 (pipe coupling)	8.5.2.7 8.5.2.8 8.5.2.9 8.5.2.23 8.5.2.31 (use of oddment) 8.5.2.32 (hooks in wet mortar) 8.5.2.33 (inclined pipes 45°) 8.5.2.36 (pipes in corner) 8.5.2.37 (pipe on the wall) 8.5.2.39 (collar to collar PG1) 8.5.2.40 (collar to collar PG2) 8.5.2.41 (collar to Mineral Wool) 8.5.2.42 (collar to CFS-B) 8.5.2.43 (collar to board) 8.5.2.45 (pipe junction / manifold) 8.5.2.46 (pipe coupling) 8.5.2.47 (Elbow 87°)

Pipe Material: PVC, non-regulated
 Manufacturer, Product / Pipe Standard: Friatec Friaphon

Application	Shaftwall	Flexible and rigid wall $t_E \geq 100$ mm $\rho_E \geq 650$ kg/m ³ (for rigid wall only)	Rigid wall $t_E \geq 100$ mm $\rho_E \geq 650$ kg/m ³	Rigid wall $t_E \geq 150$ mm $\rho_E \geq 650$ kg/m ³	Rigid floor $t_E \geq 150$ mm $\rho_E \geq 650$ kg/m ³
Waste water	---	8.3.2.13	8.3.2.13	8.3.2.13 8.4.2.31	8.5.2.11 8.5.2.27 8.5.2.31 (use of oddment) 8.5.2.32 (hooks in wet mortar) 8.5.2.33 (inclined pipes 45°) 8.5.2.36 (pipes in corner) 8.5.2.37 (pipe on the wall) 8.5.2.39 (collar to collar PG1) 8.5.2.41 (collar to Mineral Wool) 8.5.2.42 (collar to CFS-B) 8.5.2.43 (collar to board) 8.5.2.45 (pipe junction / manifold)

electronic copy

Pipe Material: PP (non-regulated by EN standards)
 Manufacturer, Product / Pipe Standard: Coes Blue Power, Coes PhoNo Fire, Conel Drain
 Hausabflußrohr, Geberit Silent PP, Geberit Silent Pro, Marley Silent, Ostendorf Skolan db, Pipelife Master 3, Poloplast Polokal NG, Poloplast Polokal 3S, Poloplast Polokal XS, Rehau Raupiano Plus, Silenta Premium, Ke Kelit PhonEx AS, Valsir Triplus, Valsir Silere, Wavin SiTech, Wavin SiTech+, Wavin AS or equal products, Uponor S&W Decibel

Application	Shaftwall	Flexible and rigid wall $t_E \geq 100$ mm $\rho_E \geq 650$ kg/m ³ (for rigid wall only)	Rigid wall $t_E \geq 100$ mm $\rho_E \geq 650$ kg/m ³	Rigid wall $t_E \geq 150$ mm $\rho_E \geq 650$ kg/m ³	Rigid floor $t_E \geq 150$ mm $\rho_E \geq 650$ kg/m ³
Waste water	8.6.2.4, 8.6.3.2, 8.6.3.4 (87° elbow), 8.6.3.5 (2 x 45° elbow), 8.6.3.6 (pipe coupling) 8.6.3.7 (collar to collar) 8.6.3.9 (Collar to ACP) 8.6.3.11 (Collar to ACP and electric conduits)	8.3.2.9, 8.3.2.17 and 7.2.2.19 (pipe coupling), 8.3.2.18 (87° elbow), 8.3.2.20 (2x45° elbow) 8.3.2.21 (inclined 45°) 8.3.2.22 (collar to Mineral Wool) 8.3.2.23 (collar to CFS-B) 8.3.2.24 (collar to board) 8.3.2.25 (collar to collar PG1)	8.3.2.9, 8.3.2.17 and 7.2.2.19 (pipe coupling), 8.3.2.18 (87° elbow), 8.3.2.20 (2x45° elbow) 8.3.2.21 (inclined 45°) 8.3.2.22 (collar to Mineral Wool) 8.3.2.23 (collar to CFS-B) 8.3.2.24 (collar to board) 8.3.2.25 (collar to collar PG1) 8.4.2.5 8.4.2.8 (pipe on the wall) 8.4.2.11 (roof drainage) 8.4.2.14 (use of oddment) 8.4.2.15 (hooks in mortar) 8.4.2.17 (87° elbow), 8.4.2.18 (2x45° elbow) 8.4.2.19 (pipes in corner)	8.3.2.9, 8.3.2.17 and 7.2.2.19 (pipe coupling), 8.3.2.18 (87° elbow), 8.3.2.20 (2x45° elbow) 8.3.2.21 (inclined 45°) 8.3.2.22 (collar to Mineral Wool) 8.3.2.23 (collar to CFS-B) 8.3.2.24 (collar to board) 8.3.2.25 (collar to collar PG1) 8.4.2.5 8.4.2.8 (pipe on the wall) 8.4.2.11 roof drainage 8.4.2.14 (use of oddment) 8.4.2.15 (hooks in mortar) 8.4.2.17 (87° elbow), 8.4.2.18 (2x45° elbow) 8.4.2.19 (pipes in corner) 8.4.2.25 8.4.2.32 (collar to collar PG2)	8.5.2.6 8.5.2.22 8.5.2.31 (use of oddment) 8.5.2.32 (hooks in wet mortar) 8.5.2.33 (inclined pipes 45°) 8.5.2.34 (87° elbow pipes) 8.5.2.35 (2x45° elbow pipes) 8.5.2.36 (pipes in corner) 8.5.2.37 (pipe on the wall) 8.5.2.38 (pipe coupling), 8.5.2.38 (collar to collar PG1) 8.5.2.40 (collar to collar PG2) 8.5.2.41 (collar to Mineral Wool) 8.5.2.42 (collar to CFS-B) 8.5.2.43 (collar to board) 8.5.2.44 (roof drainage) 8.5.2.45 (pipe junction / manifold)

Pipe Material: ABS and SAN+PVC pipes
 Manufacturer, Product / Pipe Standard: EN 1455-1 and EN 15493, EN 1565-1

Application	Shaftwall	Flexible and rigid wall $t_E \geq 100$ mm $\rho_E \geq 650$ kg/m ³ (for rigid wall only)	Rigid wall $t_E \geq 100$ mm $\rho_E \geq 650$ kg/m ³	Rigid wall $t_E \geq 150$ mm $\rho_E \geq 650$ kg/m ³	Rigid floor $t_E \geq 150$ mm $\rho_E \geq 650$ kg/m ³
Various	8.6.2.7	8.3.2.2, 8.3.2.3, 8.3.2.21 (inclined 45°) 8.3.2.22 (collar to Mineral Wool) 8.3.2.23 (collar to CFS-B) 8.3.2.24 (collar to board) 8.3.2.25 (collar to collar PG1)	8.3.2.2 8.3.2.3, 8.3.2.21 (inclined 45°) 8.3.2.22 (collar to Mineral Wool) 8.3.2.23 (collar to CFS-B) 8.3.2.24 (collar to board) 8.3.2.25 (collar to collar PG1) 8.4.2.8 (pipe on the wall) 8.4.2.14 (use of oddment) 8.4.2.15 (hooks in mortar) 8.4.2.19 (pipes in corner)	8.3.2.2 8.3.2.3, 8.3.2.21 (inclined 45°) 8.3.2.22 (collar to Mineral Wool) 8.3.2.23 (collar to CFS-B) 8.3.2.24 (collar to board) 8.3.2.25 (collar to collar PG1) 8.4.2.8 (pipe on the wall) 8.4.2.14 (use of oddment) 8.4.2.15 (hooks in mortar) 8.4.2.19 (pipes in corner) 8.4.2.21 8.4.2.22 8.4.2.32 (collar to collar PG2)	8.5.2.2 8.5.2.16 8.5.2.17 8.5.2.31 (use of oddment) 8.5.2.32 (hooks in wet mortar) 8.5.2.33 (inclined pipes 45°) 8.5.2.36 (pipes in corner) 8.5.2.37 (pipe on the wall) 8.5.2.39 (collar to collar PG1) 8.5.2.40 (collar to collar PG2) 8.5.2.41 (collar to Mineral Wool) 8.5.2.42 (collar to CFS-B) 8.5.2.43 (collar to board) 8.5.2.45 (pipe junction / manifold)

Pipe Material: PVC-U
Manufacturer, Product / Pipe Standard: DIN 6660

Application	Shaftwall	Flexible and rigid wall $t_E \geq 100$ mm $\rho_E \geq 650$ kg/m (for rigid wall only)	Rigid wall $t_E \geq 100$ mm $\rho_E \geq 650$ kg/m ³	Rigid wall $t_E \geq 150$ mm $\rho_E \geq 650$ kg/m ³	Rigid floor $t_E \geq 150$ mm $\rho_E \geq 650$ kg/m ³
Pneumatic dispatch systems	---	8.3.2.14	8.3.2.14	8.3.2.14	8.5.2.12
			8.4.2.8	8.4.2.29	8.5.2.24

Pipe Material: PE (1), (2), PP (3)
Manufacturer, Product / Pipe Standard: (1): EN 1519-1, EN12666-1, EN 12201-2
(2): non-regulated; Geberit Silent dB 20
(3): non-regulated; see 8.2.15

Application	Shaftwall	Flexible and rigid wall $t_E \geq 100$ mm $\rho_E \geq 650$ kg/m ³ (for rigid wall only)	Rigid wall $t_E \geq 100$ mm $\rho_E \geq 650$ kg/m ³	Rigid wall $t_E \geq 150$ mm $\rho_E \geq 650$ kg/m ³	Rigid floor $t_E \geq 150$ mm $\rho_E \geq 650$ kg/m ³
Roof drainage	---	---	8.4.2.11 (A – D)	8.4.2.11 (A – D)	8.5.2.44 (A – D)

Pipe Material: PP-R
Manufacturer, Product / Pipe Standard: EN 15874 (Aquatherm fusiolen = aquatherm green pipe S)

Application	Shaftwall	Flexible and rigid wall $t_E \geq 100$ mm $\rho_E \geq 650$ kg/m ³ (for rigid wall only)	Rigid wall $t_E \geq 100$ mm $\rho_E \geq 650$ kg/m ³	Rigid wall $t_E \geq 150$ mm $\rho_E \geq 650$ kg/m ³	Rigid floor $t_E \geq 150$ mm $\rho_E \geq 650$ kg/m ³
heating, sprinkler, fresh water	---	8.3.2.16	8.3.2.16	8.3.2.16	8.5.2.28
			8.4.2.10 (multiple pipe)	8.4.2.10 (multiple pipe)	8.5.2.29 (multiple pipe)
			8.4.2.11 (heating)	8.4.2.11 (heating)	

Pipe Material: PE-X
 Manufacturer, Product / Pipe Standard: Wavin Tigris PE-X R-I-R

Application	Shaftwall	Flexible and rigid wall $t_E \geq 100$ mm $\rho_E \geq 650$ kg/m ³ (for rigid wall only)	Rigid wall $t_E \geq 100$ mm $\rho_E \geq 650$ kg/m ³	Rigid wall $t_E \geq 150$ mm $\rho_E \geq 650$ kg/m ³	Rigid floor $t_E \geq 150$ mm $\rho_E \geq 650$ kg/m ³
heating, sprinkler, fresh water	---	---	8.4.2.34	8.4.2.34	8.5.2.49

Pipe Material: PE-X
 Manufacturer, Product / Pipe Standard: EN 15875 (Rehau Rautitan flex)

Application	Shaftwall	Flexible and rigid wall $t_E \geq 100$ mm $\rho_E \geq 650$ kg/m ³ (for rigid wall only)	Rigid wall $t_E \geq 100$ mm $\rho_E \geq 650$ kg/m ³	Rigid wall $t_E \geq 150$ mm $\rho_E \geq 650$ kg/m ³	Rigid floor $t_E \geq 150$ mm $\rho_E \geq 650$ kg/m ³
heating, sprinkler, fresh water	---	8.3.2.15	8.3.2.15 8.4.2.10 (multiple pipe) 8.4.2.11 (heating)	8.3.2.15 8.4.2.10 (multiple pipe) 8.4.2.11 (heating)	8.5.2.27 8.5.2.29 (multiple pipe)

electronic copy

Pipe Material: PVC
 Manufacturer, Product / Pipe Standard: EN 1452-1, EN 1329-1, EN 1453-1, EN 1566-1; DIN 8061/62, EN ISO 15493

Application	Shaftwall	Flexible and rigid wall $t_E \geq 100$ mm $\rho_E \geq 650$ kg/m ³ (for rigid wall only)	Rigid wall $t_E \geq 100$ mm $\rho_E \geq 650$ kg/m ³	Rigid wall $t_E \geq 150$ mm $\rho_E \geq 650$ kg/m ³	Rigid floor $t_E \geq 150$ mm $\rho_E \geq 650$ kg/m ³
Waste water	8.6.2.3	8.3.2.8, 8.3.2.21 (inclined 45°) 8.3.2.22 (collar to Mineral Wool) 8.3.2.23 (collar to CFS-B) 8.3.2.24 (collar to board) 8.3.2.25 (collar to collar PG1) 8.3.2.27 (Elbow 87°)	8.3.2.8, 8.3.2.21 (inclined 45°) 8.3.2.22 (collar to Mineral Wool) 8.3.2.23 (collar to CFS-B) 8.3.2.24 (collar to board) 8.3.2.25 (collar to collar PG1) 8.3.2.27 (Elbow 87°) 8.4.2.4 8.4.2.8 (pipe on the wall) 8.4.2.14 (use of oddment) 8.4.2.15 (hooks in mortar) 8.4.2.19 (pipes in corner)	8.3.2.8, 8.3.2.21 (inclined 45°) 8.3.2.22 (collar to Mineral Wool) 8.3.2.23 (collar to CFS-B) 8.3.2.24 (collar to board) 8.3.2.25 (collar to collar PG1) 8.3.2.27 (Elbow 87°) 8.4.2.4 8.4.2.8 (pipe on the wall) 8.4.2.14 (use of oddment) 8.4.2.15 (hooks in mortar) 8.4.2.19 (pipes in corner) 8.4.2.24 8.4.2.32 (collar to collar PG2)	8.5.2.4 8.5.2.5 8.5.2.21 8.5.2.26 8.5.2.31 (use of oddment) 8.5.2.32 (hooks in wet mortar) 8.5.2.33 (inclined pipes 45°) 8.5.2.36 (pipes in corner) 8.5.2.37 (pipe on the wall) 8.5.2.39 (collar to collar PG1) 8.5.2.40 (collar to collar PG2) 8.5.2.41 (collar to Mineral Wool) 8.5.2.42 (collar to CFS-B) 8.5.2.43 (collar to board) 8.5.2.45 (pipe junction / manifold) 8.5.2.48 (Elbow 87°)

8.2 General Information Hilti Firestop Collar Endless CFS-C EL

8.2.1 Penetration seal

Single penetration; Hilti Firestop Collar Endless CFS-C EL (A_1) to be mounted on both sides of the wall or on the underside of floor (soffit) only. Pipe diameter d_c ; refer to 8.3, 8.4, 8.5, 8.6.

8.2.2 Pipe Group/Application Group

The Pipe Group (PG) defines the Application Group, see table 1.
 Application Group 1 means one jacket on one side of the seal,
 Application Group 2 means two jackets on one side of the seal.

Pipe Group (PG) is mainly defined by pipe outside diameter and isolation thickness, see table 3.

Pipe Group 1 - pipes outside nominal diameter $d_c = (32,0 \text{ mm} \leq d_c \leq 110,0 \text{ mm})$.

Pipe Group 2 - pipes outside nominal diameter $d_c = (110,1 \text{ mm} \leq d_c \leq 160,0 \text{ mm})$.

Specific situation for some pipes with outside nominal diameter $d_c = 125 \text{ mm}$, where pipes are assessed within pipe group 1 (refer to 8.3, 8.4, 8.5, 8.6).

Hilti Firestop Collar Endless CFS-C EL has to be installed in contact with pipe or pipe insulation. No annular space between Collar and pipe/isolated pipe is permitted.

Application group

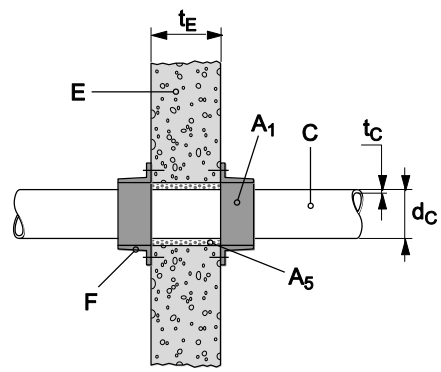
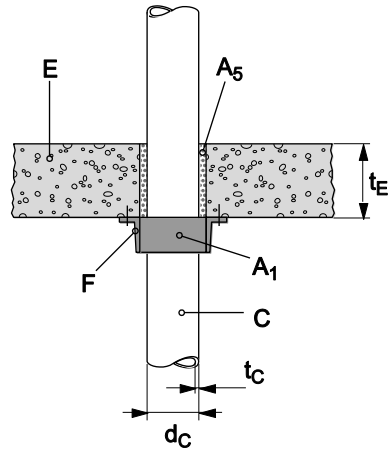
	Flexible Wall/Shaftwall/Rigid Wall	Rigid Floor
Pipe group 1 (PG1)		

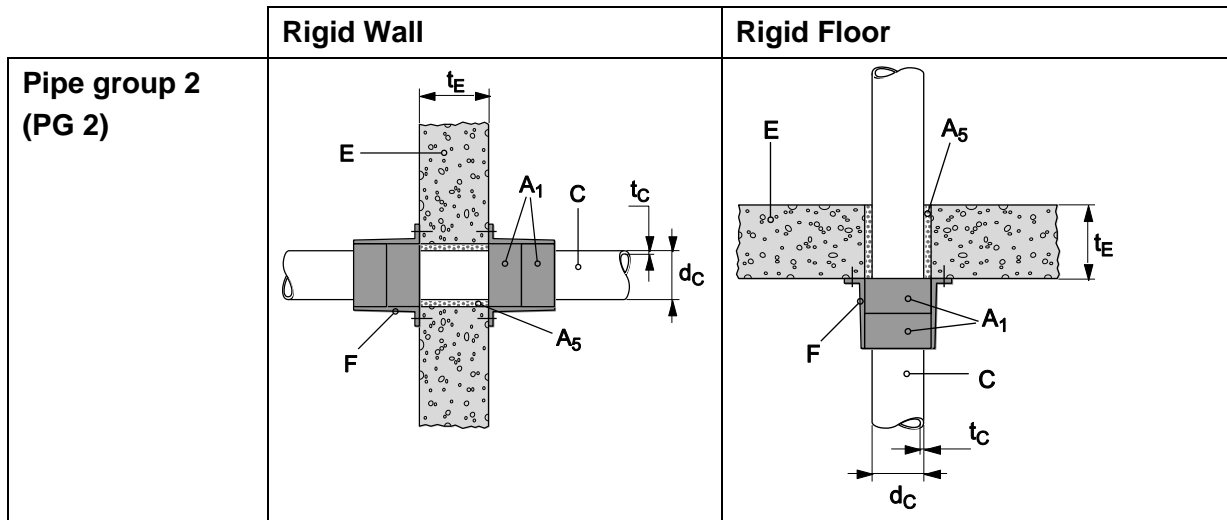

Tab.1: Application Group, defined by Pipe Group (PG) and associated substrate

8.2.3 Collar fixing

Hilti Firestop Collar Endless CFS-C EL (A_1) to be installed against the wall or floor utilizing the specified number of fixing hooks. The required number and type of hooks is shown in Tab.2.

Fixing elements for hooks in flexible walls:

1. Screw Anchor Hilti HUS H6 or P6,
2. Hollow Wall Metallic Anchor Hilti HTB-S or HTB-2, HUS3-P, HUS3-H
3. Cavity Anchor Hilti HHD-S or
4. threaded rod minimum M6 with flat washer and nut on both sides of the wall.

Fixing elements for hooks in rigid walls and floors:

1. Screw Anchor Hilti HUS H6 or P6, HUS3-P, HUS3-H
2. threaded rod minimum M6 with flat washer and nut.

Fixing elements for hooks in shaft wall systems

1. Screw Anchor Hilti HUS H6 and P6 or
2. Hollow Wall Metallic Anchor Hilti HTB-S or HTB-2, HUS3-P, HUS3-H

For CFS-C EL Collar Fixing in Mineral wool board seals (refer to 8.2.14) in flexible and solid wall or solid floor to be done using threaded rods minimum M6 with flat washer and nut, penetrating the boards.

One hook (short or long) in any wall and floor should be fixed always with one fixing element. Only in shaft wall application two hooks (one long and one short) could be fixed with one fixing element.

If a threaded rod is penetrating mineral wool (density 40 – 50 kg/m³) (used as back filler) it has to be ensured, that the supporting flat washer does not have direct contact to mineral wool. A metal plate/strip of at least 1mm thickness has to be placed over the wall/floor opening. The plate will be penetrated by the threaded rod. The nut presses then the flat washer to plate.

Bended hooks could be pressed into the wet gap seal, made of cementitious mortar in rigid walls, ($t_E \geq 100$ mm) and rigid floors ($t_E \geq 150$ mm).

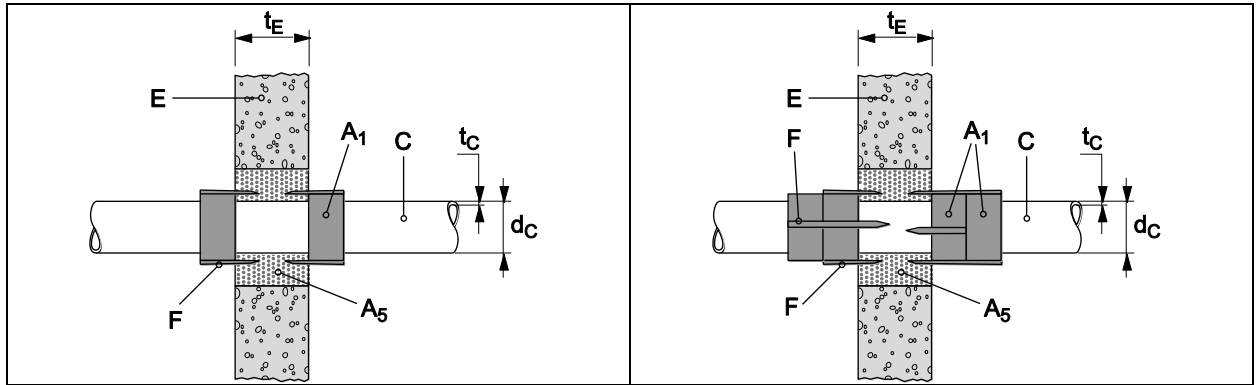

Type of wall/ Floor (material)	screw anchor Hilti HUS H6 and P6	hollow wall metallic anchor Hilti HTB-S	cavity anchor Hilti HDD-S	threaded rod M6 with disc and nut
Flexible wall	x	x	x	x
Rigid wall	x			x
Rigid floor	x			x
Shaft wall	x	x		

Tab. 2: Hook Fixing Elements for CFS-C EL, defined by building element

8.2.4 Required number of fixing hooks

Required number of hooks to fix Hilti Firestop Collar Endless CFS-C EL (A_1) to Flexible, rigid walls and rigid floors (For perpendicular penetration only)

Pipe group	Type of hooks	Nominal pipe Outside diameter d_c (mm)	Numbers of hooks					
			Max. insulation thickness (Insulation may be an acoustical insulation as described in 8.2.6 or a thermal insulation as described in 8.2.13.)					
			0 (mm)	4 mm	9 mm	13mm	19mm	25mm
PG 1	short	16			2	2		3
		32	2	2	2	2		3
		40	2	2	2	3		3
		50	2	2	2			
		56	3	3	3			
		63	3	3	3			
		75	3	3	3			
		90	3	3	3			
		110	3	3	3		5	
PG 2	short + long	125	4	4				
		125	2 + 4	2 + 4	2 + 4		2 + 4	
		135	2 + 4	2 + 4	2 + 4		2 + 4	
		140	2 + 4	2 + 4	2 + 4		2 + 5	
		160	2 + 4	2 + 4	2 + 4		2 + 5	

Tab.3: requested number and specification of fixing hooks (F)
Depending from pipe dimension and required insulation thickness

The maximum distance between two hooks is 150 mm. If the distance becomes bigger an additional hook (short or long) has to be used. The number of hooks for special application may be increased, but not decreased.

Special installation situation (inclined pipes, pipe coupling, elbow pipes, etc.) require additional hooks to fix the collar. Refer to 8.3, 8.4, 8.5, 8.6.

8.2.5 Pipe support construction

Pipes up to Ø110mm (PG 1) penetrating rigid walls, listed in **8.4.2.1; 8.4.2.2; 8.4.2.4; 8.4.2.5; 8.4.2.6;** and **Pipegroup 2** (PG 2) listed in **8.4.2.20; 8.4.2.23; 8.4.2.24; 8.4.2.25; 8.4.2.26** have to be supported at maximum 400 mm away from both faces of any walls.

In floor penetration all pipes up to Ø110mm (PG 1) listed in **8.5.2.1; 8.5.2.2; 8.5.2.3; 8.5.2.4; 8.5.2.6; 8.5.2.7; 8.5.2.10; 8.5.2.11** and **Pipegroup 2** (PG 2) listed in **8.5.2.14; 8.5.2.15; 8.5.2.19; 8.5.2.21; 8.5.2.22** have to be supported on upside only, maximum 400mm above floor level.

Pipes and application in other chapters than listed above have to be supported in max. 250 mm on both side of wall (flexible and rigid) and max. 250 mm above floor. No support below floor is requested.

8.2.6 Sound decoupling insulation

Plastic pipes can be with or without sound decoupling insulation.
 Allowed material:

- Foamed polyethylene based sound decoupling insulation, thickness (4 mm - 9 mm)
- Thermaflex, ThermoVließ B2 (Polyester), thickness 4 mm

Acoustic Pipe Insulation penetrates the wall/floor element, as well as the Hilti Firestop Collar Endless CFS-C EL.

Sound decoupling insulation can be used in LS and CS situation.

8.2.7 Utilization of small intumescent sections (oddments)

Minimum length of oddments is 120 mm.

	Flexible wall ($t_E \geq 100\text{mm}$)	Massive wall ($t_E \geq 100\text{mm}$)	Massive floor ($t_E \geq 150\text{mm}$)	Shaftwall
Oddments allowed	Yes	Yes	Yes	No

Oddment together with an additional intumescent section has to fulfil recommended bandage length, see Annex 5. Both pieces (oddment and the additional section) have to be equipped identically with the closure plates. Those two pieces should be stucked together, than wrapped around the pipe, closed and fixed.

For pipes in application group 2 the collar containing the oddment has to be mounted to the wall/floor. The other collar must not contain oddments.

Maximum one oddment could be used within one collar. Maximum one collar for a single penetration may contain an oddment piece.

Number of hooks used to fix a collar (containing an oddment) in application group 1 to massive walls/floors: at least 4

Number of hooks used to fix a collar (containing an oddment) in application group 2 to massive walls/floors: at least 4

Details for integrity and insulation please refer to 8.4.2.12 and 8.5.2.28.

Oddments should be added to collars in perpendicular pipe position in rigid floor and walls only.

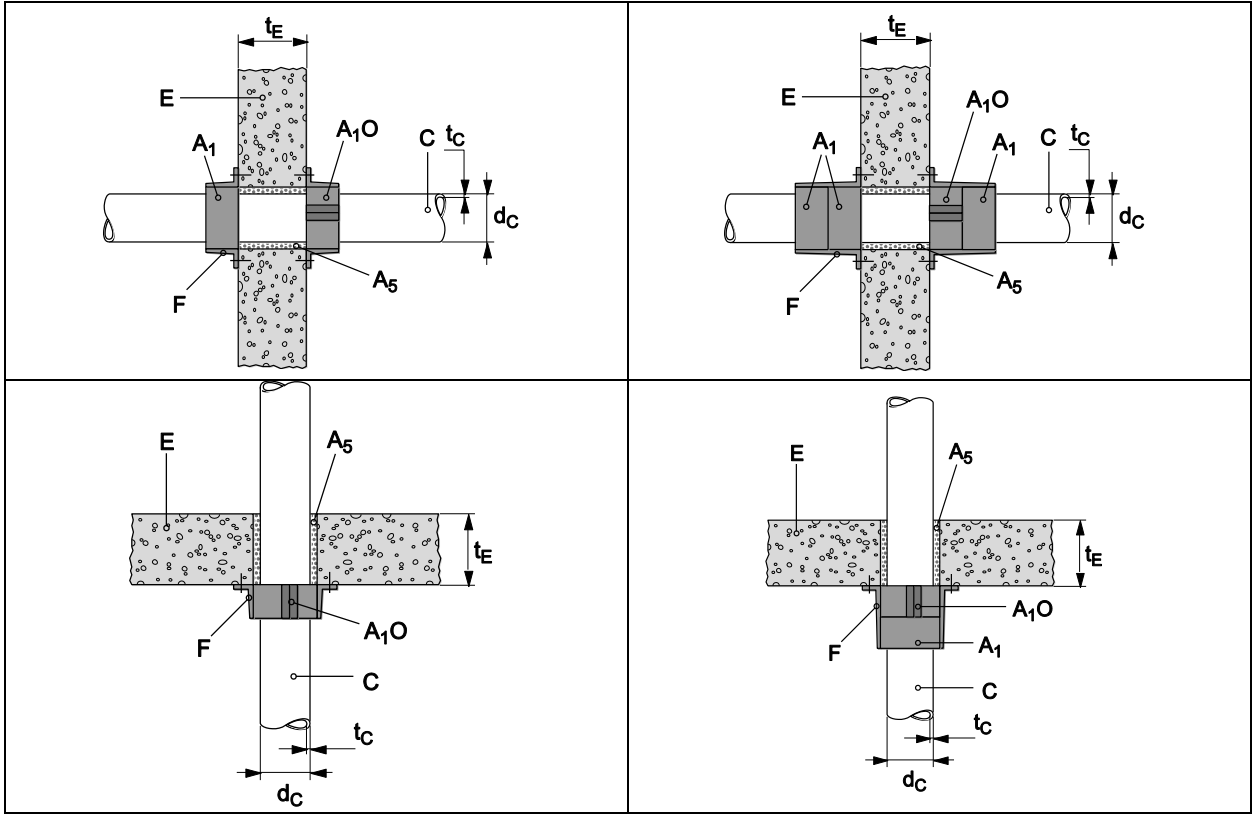

Pipes containing oddments in pipe group 1 and 2 in wall and floor penetration

8.2.8 Pipe orientation

Pipes in pipe group 1 (see 8.2.2) may penetrate flexible and rigid walls and rigid floors in an inclination between 45° and 90°. This is valid for flexible or rigid walls thickness ($t_E \geq 100\text{mm}$) and rigid floor ($t_E \geq 150\text{mm}$).

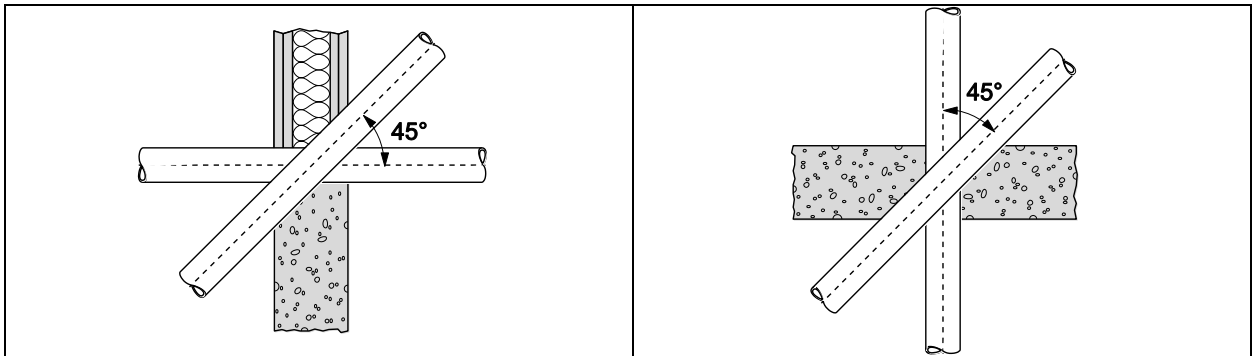

Pipes in pipe group 2 (see 8.2.2) have to penetrate walls/floors in perpendicular (90°) situation only.

electronic copy

8.2.9 Distance between penetrations

For pipes in pipe group 1 (see 8.2.2)

Flexible wall and rigid wall ($t_E \geq 100$ mm)

- distance between collars ($s_1 \geq 0$ mm)
- Max. number of pipes in line: unlimited.

Rigid floor ($t_E \geq 150$ mm):

- distance between collars ($s_1 \geq 0$ mm)
- Max. number of pipes in line: unlimited.

For pipes in pipe group 2 (see 8.2.2):

In rigid wall ($t_E \geq 150$ mm):

- distance between collars ($s_1 \geq 0$ mm)
- Max. number of pipes in line: 2

Distance between two pipe clusters: ($s_2 \geq 60$ mm)

In rigid floor ($t_E \geq 150$ mm):

- Minimum distance between collars ($s_1 \geq 0$ mm)
- Max. number of pipes in line: unlimited

In timber floor and wall:

- Minimum distance between pipes > 50 mm
- Max. number of pipes in line: unlimited

When grouped, then pipes have to be grouped in line only.

In timber floors and walls the pipes can be arranged in any grouping.

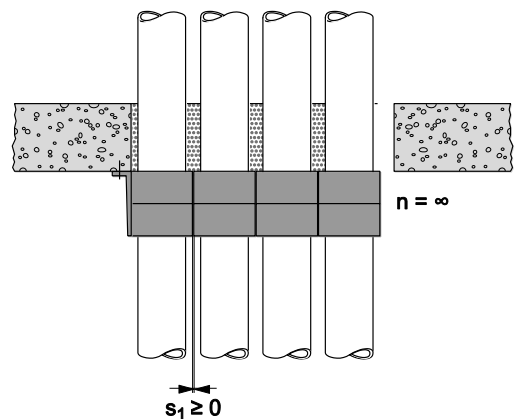
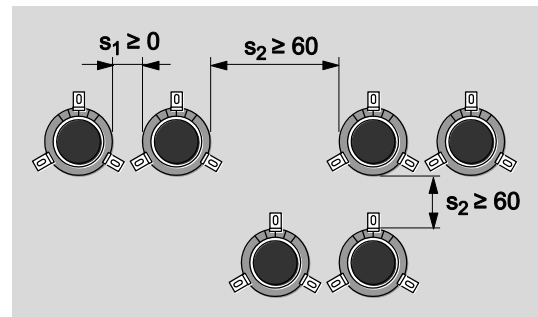
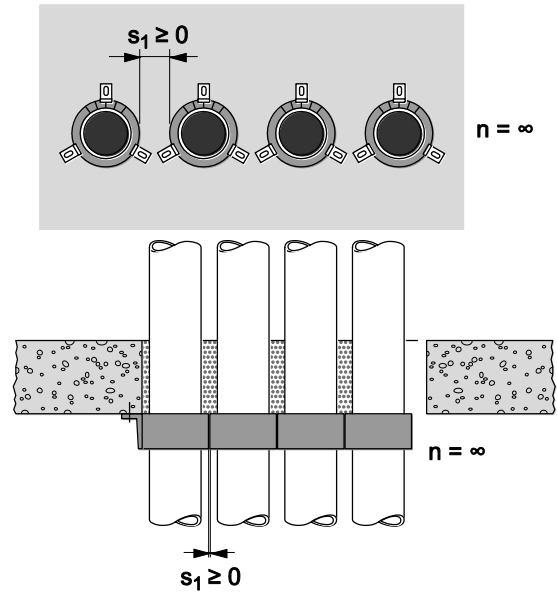

electronic copy electronic copy electronic copy electronic copy electronic copy electronic copy electronic copy electronic copy electronic copy electronic copy

8.2.10 Mineral wool

8.2.10.1 Minimum distance Hilti Firestop Collar Endless CFS-C EL to mineral wool based pipe insulation D_w , based on Conlit 150 and Rockwool 800

CFS-C EL collar on any pipe in pipe group 1 may be in direct contact to Conlit 150 and Rockwool 800 as a thermal insulation on metallic pipes. ($s_1 \geq 0$ mm).

Metal pipes:

- Material: refer to 8.2.11
- outside diameter ($d_M \leq 114,3$ mm)
- wall thickness of ($1,2$ mm $\leq t_M \leq 14,2$ mm).

Thermal insulation D_w :

- Conlit 150 inside the wall/floor only
- Rockwool 800, covering the metal pipe outside the wall/floor
- Both of combustibility class A1 or A2 in accordance with EN 13501-1

8.2.10.2 Minimum distance Hilti Firestop Collar Endless CFS-C EL to mineral wool based pipe insulation D_w , on aluminum composite pipes

CFS-C EL collar on any pipe in pipe group 1 may be used in direct contact to Mineral wool pipe insulation used as thermal insulation D_w on metallic pipes and aluminium composite pipes. ($s_1 \geq 0$ mm).

Thermal insulation D_w :

- Form: prefabricated pipe shells, coated with Al-foil Reaction to fire classification (EN 13501-1): A2 or better (Melting point: $\geq 1000^\circ\text{C}$)
- Minimum density: $\geq 70\text{kg/m}^3$
- Insulation thickness $t_D D_w \geq 20$ mm
- LS situation

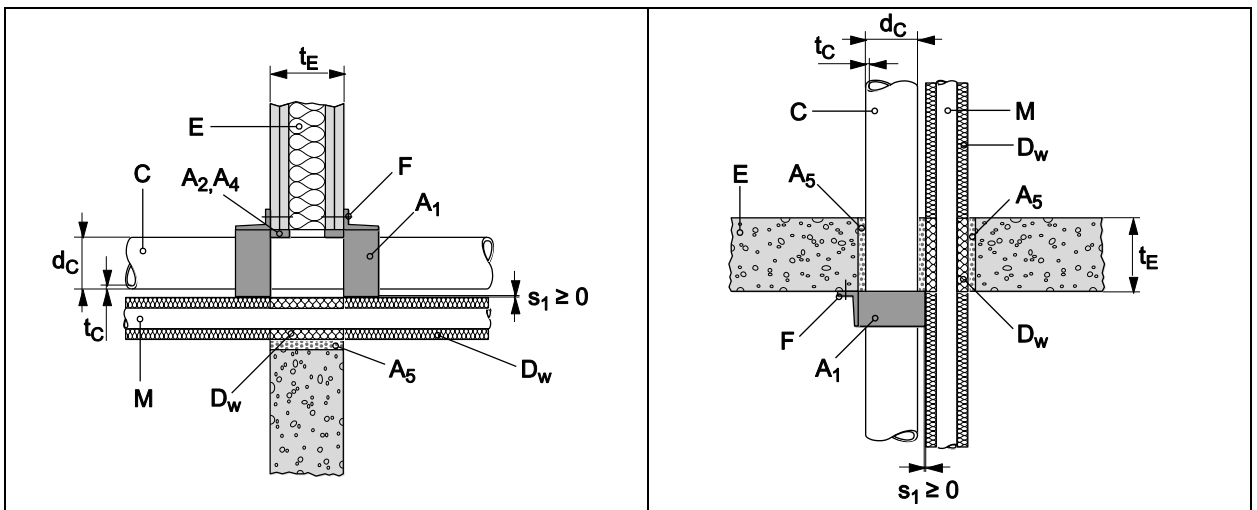

8.2.10.3 Minimum distance Hilti Firestop Collar Endless CFS-C EL to metal pipes, aluminum composite pipes and PP-R pipes insulated with a flexible, elastomeric thermal insulation D_E and fire stopped with Hilti CFS-B

CFS-C EL collar on any pipe in pipe group 1 may be in direct contact to metal pipes, insulated with flexible elastomeric foam and fire stopped with Hilti CFS-B ($s_1 \geq 0$ mm). The use of Hilti CFS-B is described in detail in ETA -10/0212.

Plastic pipes, sealed with Hilti Firestop Collar Endless CFS-C EL can penetrate a wall or floor as

- Single penetration directly beside a penetrating insulated metal pipe or aluminum composite pipe or PP-R pipe
- May penetrate the building element side by side with an insulated metal pipe as a mixed penetration.

Metal pipes:

- Made of a material described in 8.2.11
- dimensions: see specific chapters

Elastomeric foamed thermal insulation D_E in CS-situation:

- Made of a material described in 8.2.12
- D_E thickness and length: see specific chapters

In wall application with metal pipes (flexible wall and solid wall $t_E \geq 100$ mm) an additional protect insulation D_P has to be used on top of installed insulation hose and CFS-B.

Additional protect insulation D_P :

- Elastomeric material named in 8.2.12
- Length of ($L_D \geq 250$ mm) on each side of the wall
- D_P thickness ≥ 19 mm
- Local interrupted insulation (LI) does not pass through the wall.

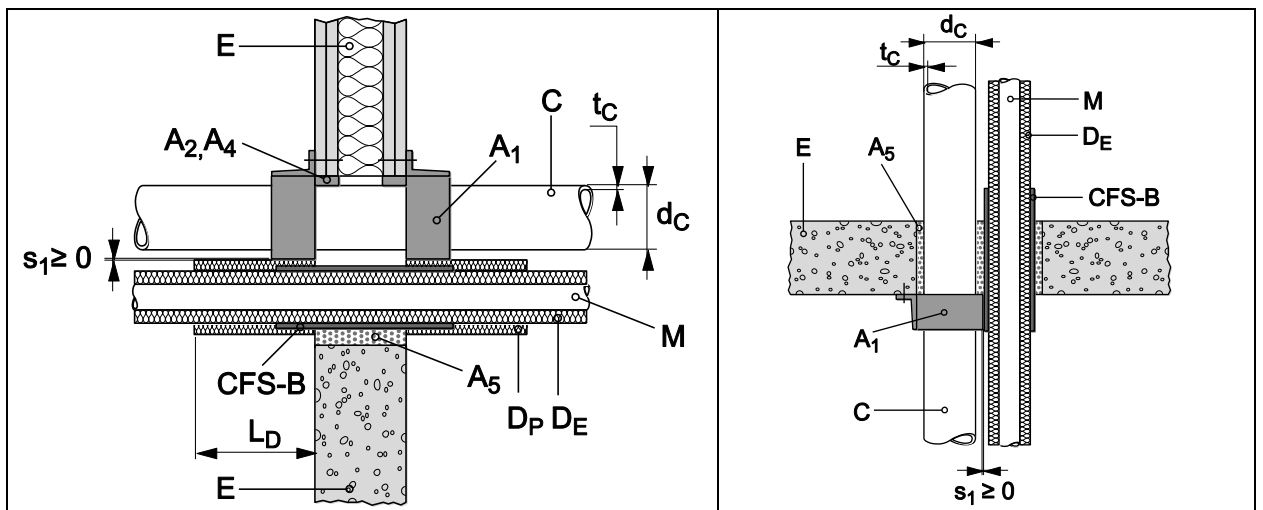

In floor application ($t_E \geq 150$ mm) there is no need for an additional protect insulation D_P .

8.2.11 Metal pipes

The field of application given above for copper pipes is also valid for other metal pipes with lower heat conductivity than copper and a melting point of minimum 1050°C , e.g. unalloyed steel, low alloyed steel, cast iron, stainless steel, Ni alloys (NiCu, NiCr, NiMo alloys) and Ni.

8.2.12 Elastomeric combustible insulation

The following types of foamed elastomeric insulation material may be used in direct contact ($s_1 \geq 0$ mm) to Hilti Firestop Collar Endless CFS-C EL:

Producer / Seller	Assessed type of foamed elastomeric thermal isolation
Armacell GmbH	Armaflex - Type: AF, SH, Ultima, HT, XG, NH
NMC Group	Insul-Tube (nmc), Insul-Tube H-Plus (nmc), Aeroflex HF
Kaimann GmbH	Kaiflex KK plus, Kaiflex KK, HF plus, EPDM plus
L'Isolante K-Flex	l'Isolante K-Flex - Type: HT, ECO, ST, H, ST Plus, ST Frigo
CONEL GmbH	Conel Flex HT
Union Foam AG	Eurobatex
A.Würth GmbH & Co.KG	Flexen
3i Intern. Innovative Industries S.A.	Isopipe HAT
Isidem / Yalitim	Coolflex AF
ODE	R-flex RPM

Named material may be used in form of an insulation hose, bandage/wrap or plates. If a protect insulation D_P is used, it should be made of the same elastomeric material as the thermal pipe isolation itself.

8.2.13 PE based foamed thermal pipe insulation

The following types of foamed elastomeric insulation material may be used in direct contact ($s_1 > 0$ mm) to Hilti Firestop Collar Endless CFS-C EL:

Producer / Seller	Assessed types
Conel	Flex PE
Thermaflex	Thermocompact TF
nmc	Klimaflex stabil Abfluss, Klimaflex PE-Schaum, Klimaflex stabil PE-Schaum,
Kaimann	PE-DWS Abwasserschlauch, Kaifoam PE-RO
Armacell GmbH	Tubolit Fonowave
Wieland	Wicuflex PE
Frigotechnik	Frigoline MKM PE Dämmung

8.2.14 Hilti Firestop Double Board Seal

Hilti Firestop Collar Endless CFS-C EL may be used to seal plastic pipes penetrating flexible boards installed in flexible wall and rigid wall ($t_E \geq 100$ mm) and floor ($t_E \geq 150$ mm). The flexible boards are covered within the ETA-11/0429 - Hilti Firestop Double Board Seal.

The following types of boards are allowed:

- Hilti Firestop Board CFS-CT B 1S (refer to Annex 2, 7.2)
- Hilti Firestop Board CFS-CT B 2S (refer to Annex 2, 7.2)
- Hilti Firestop Coating CFS-CT applied on uncoated mineral wool boards (refer to Annex 2, 7.2)

Only pipes of pipe group 1 ($d_c \leq 110$ mm) may be used in combination with Hilti Firestop Double Board Seal.

Gap seal:

- Between pipe and board with Hilti Firestop Acrylic Sealant CFS-S ACR
- Between pipe and basement with Hilti Firestop Acrylic Sealant CFS-S ACR
- Gap pipe to basement ($s_3 \geq 0$ mm)

Distance in between installed pipes (s_1):

- In rigid wall and flexible wall is ($s_1 \geq 80$ mm)
- In a rigid floor is ($s_1 \geq 100$ mm)

Collar fixing: refer to 8.2.3

Pipe grouping:

In rigid wall and flexible wall ($t_E \geq 100$ mm):

- Pipes have to be grouped in line, not in clusters
- An unlimited number of pipes group in line is allowed

In rigid floor ($t_E \geq 150$ mm):

- Pipes have to be grouped in line, not in clusters
- An unlimited number of pipes group in line is allowed

In flexible wall / rigid wall and rigid floor boards have to be installed flush with surface. If the basement is thicker than 100 mm the free space between both (flush with surface installed boards) have to be filled with mineral wool according detailed description in ETA-11/0429 - Hilti Firestop Double Board Seal.

8.2.15 Non-regulated acoustic PP-pipes

The following types of mineral reinforced non-regulated PP-pipes are allowed in different configurations:

- Coes Blue Power
- Coes PhoNo Fire
- Conel Drain Hausa
- Geberit Silent PP
- Geberit Silent Pro
- GF Silenta Premium
- KE KELIT PhonEx AS
- Marley Silent
- Ostendorf Skolan db
- Pipelife Master 3
- Poloplast Polokal NG
- Poloplast Polokal 3S
- Poloplast Polokal XS
- Rehau Raupiano Plus
- Valsir Silere
- Valsir Triplus
- Wavin AS
- Wavin SiTech
- Wavin SiTech +
- Uponor S&W Decibel

8.3 Flexible walls

8.3.1 Specific characteristics for Flexible walls ($t_E \geq 100$ mm)

8.3.1.1 Flexible walls – wall construction

The wall must have a minimum thickness of 100 mm and comprise timber or steel studs lined on both faces with minimum 2 layers of 12,5 mm thick boards.

For timber stud walls there must be a minimum distance of 100 mm of the seal to any stud and the cavity between stud and seal must be closed. A minimum 100 mm insulation of Class A1 or A2 (in accordance with EN 13501-1) has to remain in the cavity between stud and seal. In steel stud construction the space between linings has not to be completely filled with insulation material, especially in the neighbourhood to the seal. Nevertheless, the wall construction has to be set up according requirements given in EN 1366-3:2009 or the construction itself has been classified according EN 13501-2.

The wall comprises timber or steel studs lined on both faces with minimum 2 layers of 12,5 mm thick boards. A higher number of board layers is accepted if the overall board layer thickness is equal or bigger than tested. A higher overall board layer thickness is accepted, if the number of board layers is equal or bigger than tested.

The boards are according EN 520 type F or according the specification of the tested and assessed flexible wall construction system according EN 13501-2.

An aperture framing inside the wall is not required.

8.3.1.2 Annular gap

Annular gaps around pipes in flexible walls should be filled with either

- Gypsum based mortar
- Hilti Firestop Acrylic sealant CFS-S ACR
- Joint filler has to be installed from both sides of the flexible wall
- Minimum installation depth of ($t_{A2} \geq 25$ mm)
- Gap width: 0 – 15 mm
- Backfilling is not requested

8.3.1.3 Collar fixing

Hilti Firestop Collar Endless CFS-C EL (A_1) has to be fixed with hooks (F) on the wall. The requested number and type of hooks is shown in 8.2.3, Tab.2.

Hooks fixing in flexible walls is described in 8.2.4, Tab.3.

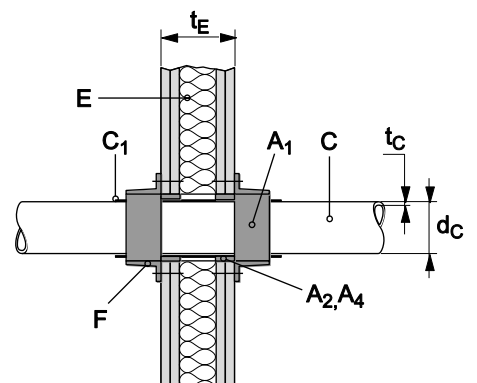
<p>Annular gap seal (drawings show insulated and non-insulated pipes)</p>	
<p>Plastic Pipe, penetrating a flexible wall construction, with or without sound decoupling insulation (C_1), gap sealed with gypsum or CFS-S ACR acrylic sealant. Back filling is not requested.</p>	

8.3.2 Penetrating services in 100 mm flexible wall

All test results from flexible wall testing ($t_E \geq 100$ mm) are applicable for rigid walls ($t_E \geq 100$ mm).

8.3.2.1 PE pipes acc. EN 1519-1, EN 12666-1, EN 12201-2 and ABS-pipes acc. EN 1455-1 and SAN+PVC-pipes acc. EN 1565-1 in flexible wall, ($t_E \geq 100$ mm), pipe group 1, EI 120 - U/U

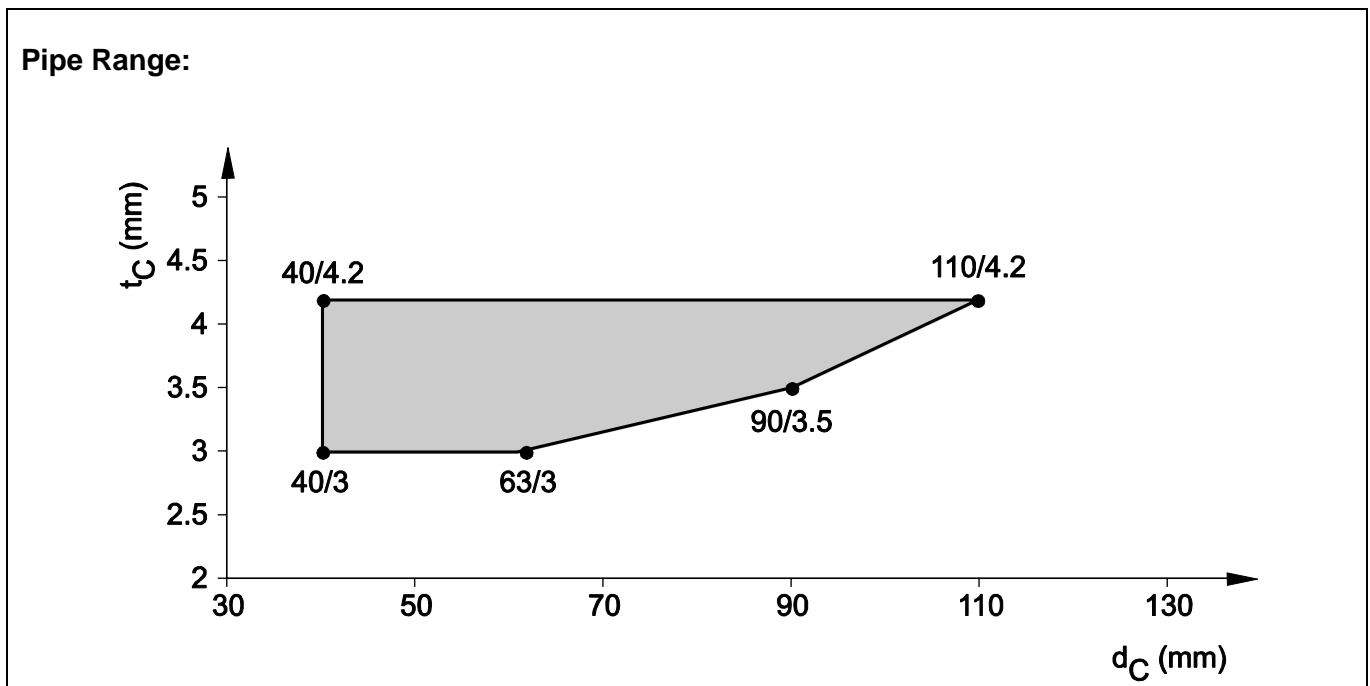

8.3.2.2 **ABS- pipes acc. EN 1455, EN 15493 and SAN+PVC-pipes acc. EN 1565-1, in flexible wall, ($t_E \geq 100$ mm), pipe group 1, EI 90 - U/U**

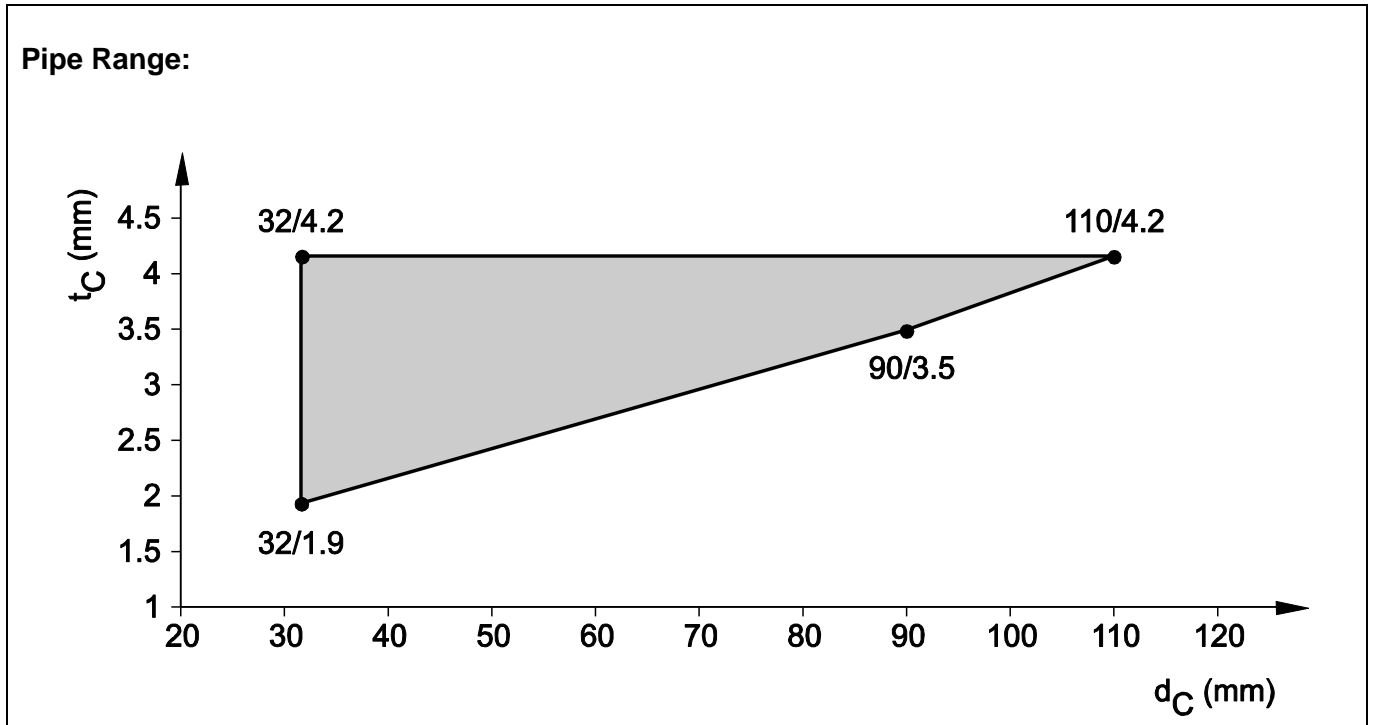

8.3.2.3 **ABS- pipes acc. EN 1455, EN 15493 and SAN+PVC-pipes acc. EN 1565-1, in flexible wall, ($t_E \geq 100$ mm), pipe group 1, EI 60 - U/U**

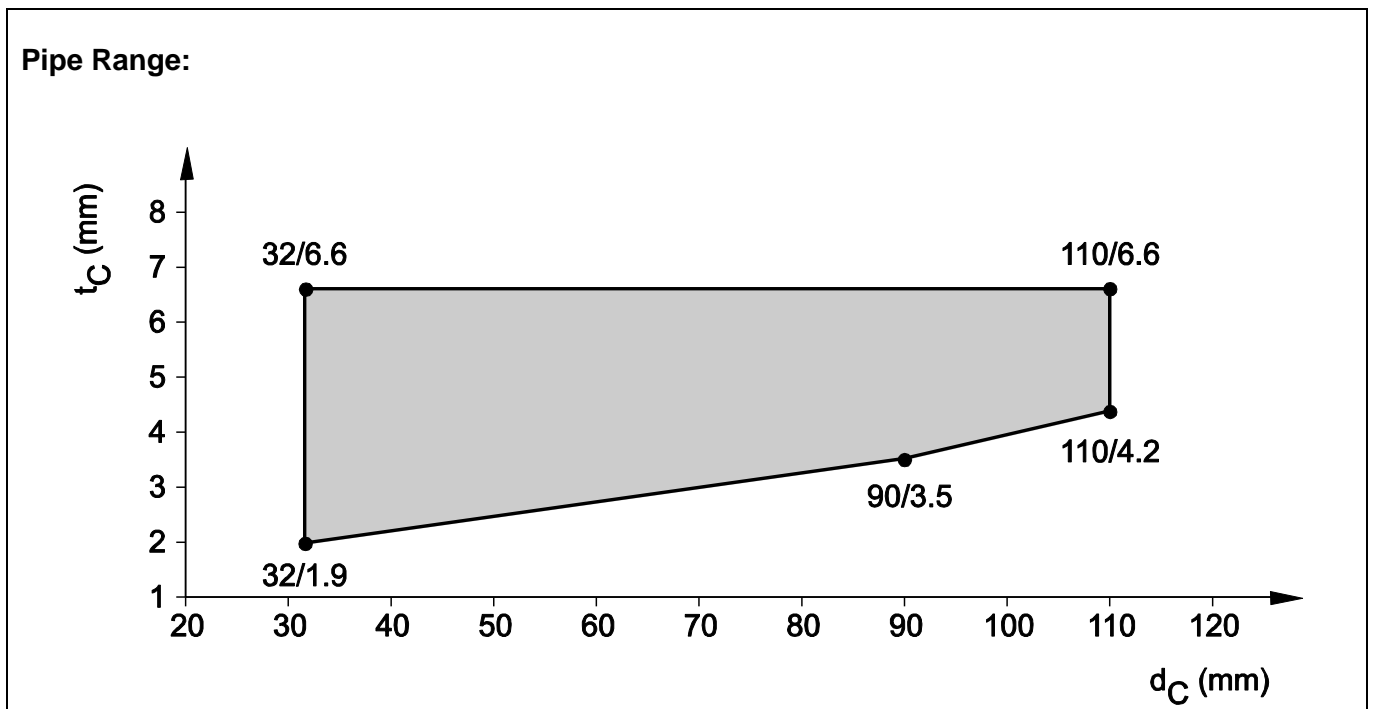

8.3.2.4 PE pipes acc. EN 15494, EN 12201-2 and DIN 8074/75 in flexible wall, ($t_E \geq 100$ mm), pipe group 1, EI 120 - U/U

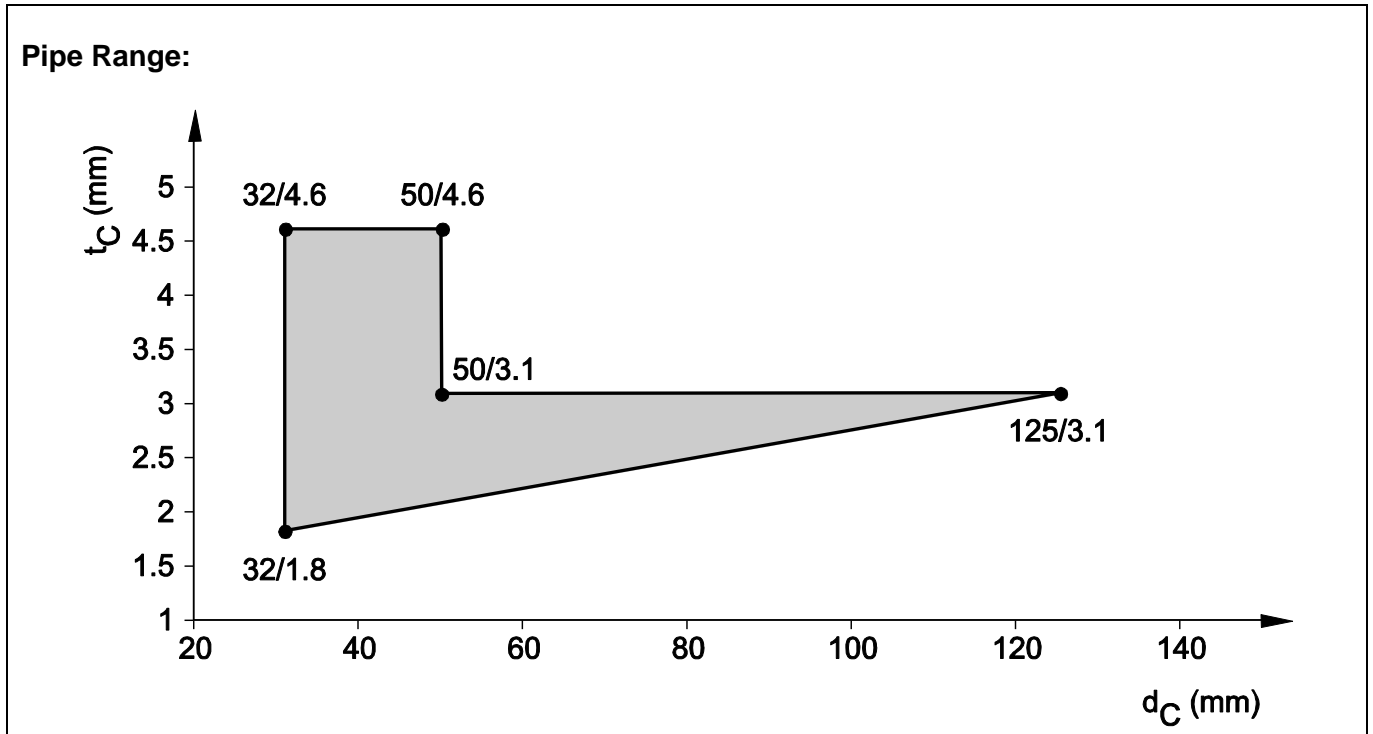

8.3.2.5 PE pipes acc. EN 15494, EN 12201-2 and DIN 8074/75 in flexible wall, ($t_E \geq 100$ mm), pipe group 1, EI 90 - U/U

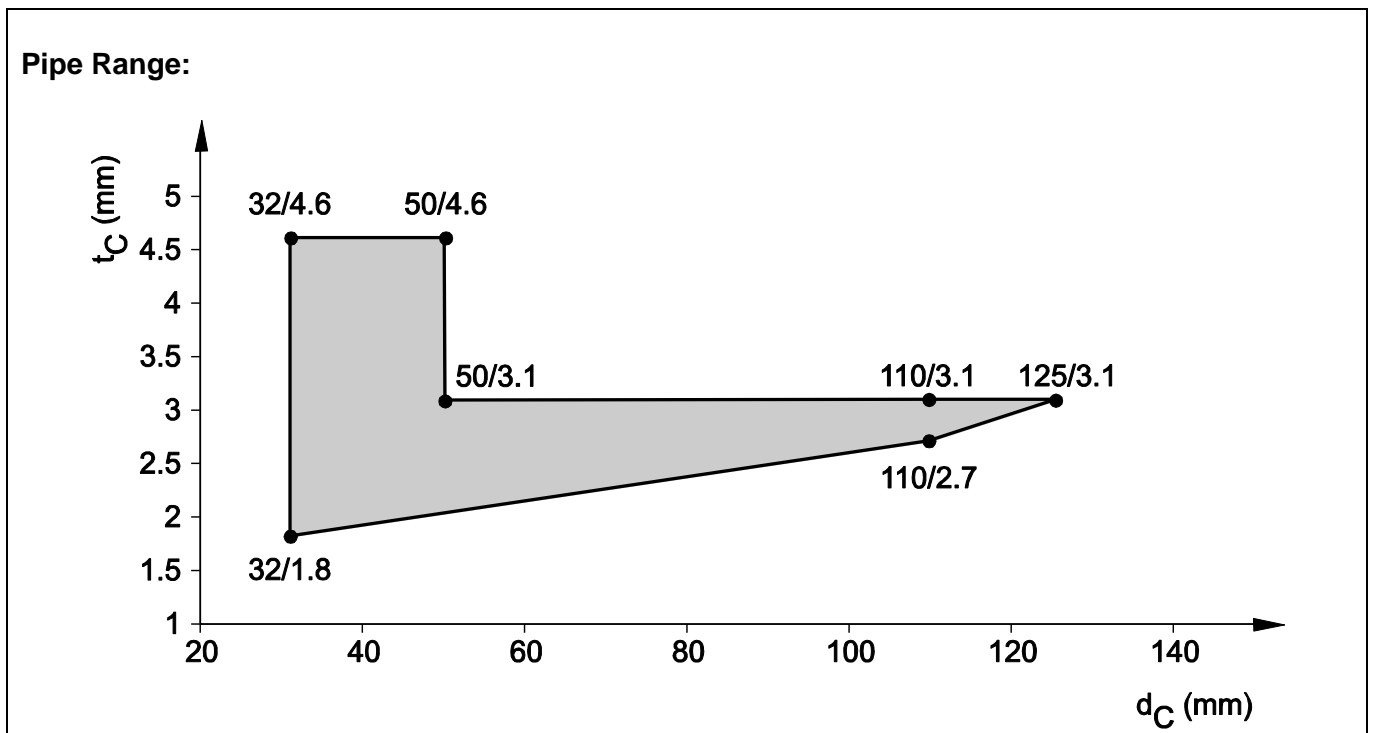

8.3.2.6 PE pipes acc. EN 15494, EN 12201-2 and DIN 8074/75 in flexible wall ($t_E \geq 100$ mm), pipe group 1, EI 120 - U/C

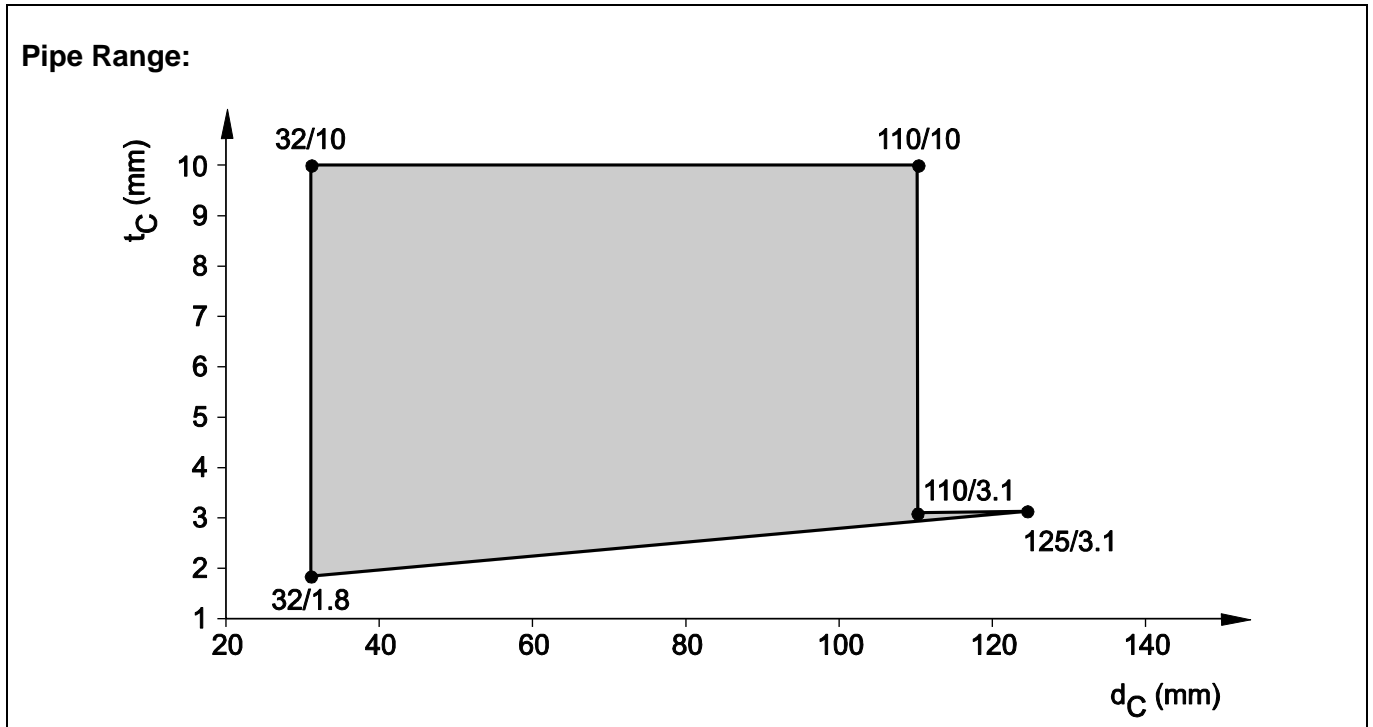

8.3.2.7 PE pipes acc. EN 15494, EN 12201-2 and DIN 8074/75 in flexible wall ($t_E \geq 100$ mm), pipe group 1, EI 90 - U/C

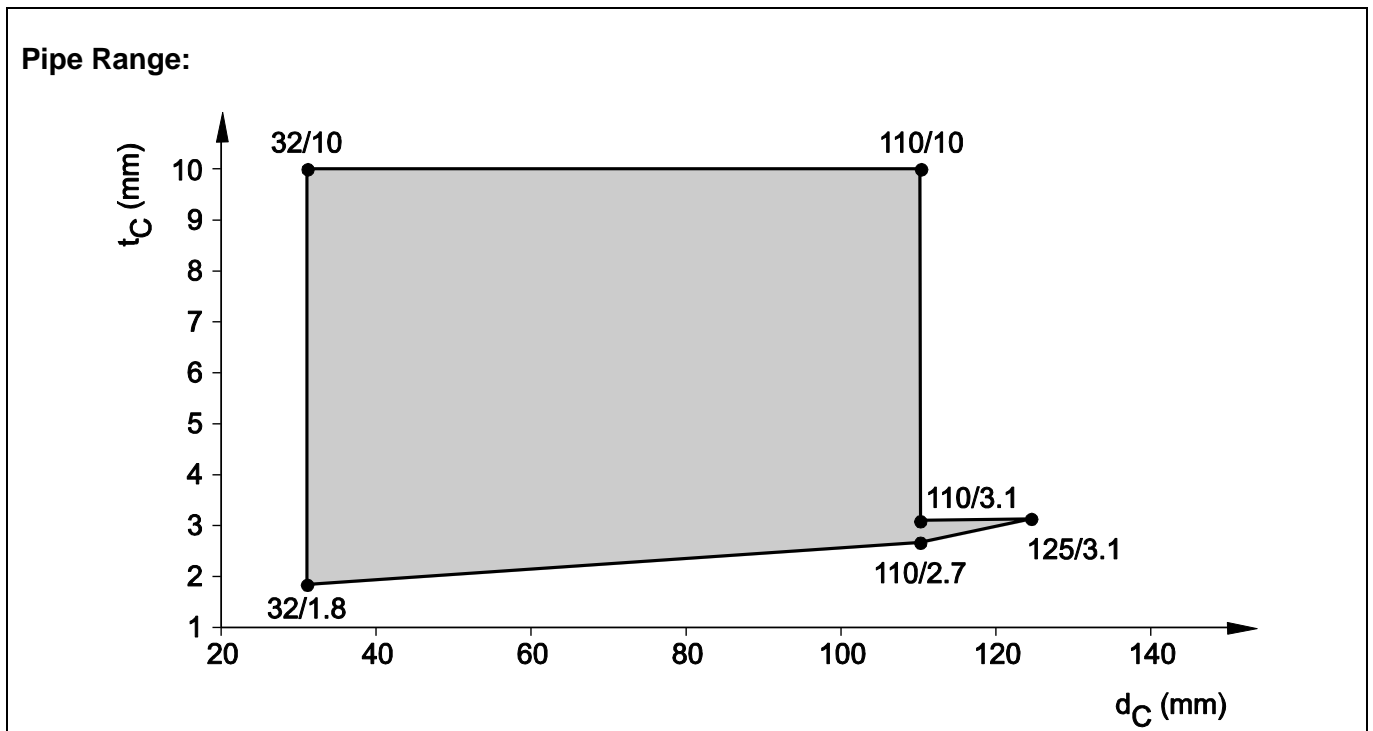

8.3.2.8 PVC pipes acc. EN 1452-1, EN 1329-1, EN 1453-1, EN 1566-1, EN ISO 15493 and DIN 8061/62 in flexible wall ($t_E \geq 100$ mm), pipe group 1, EI 120 - U/U

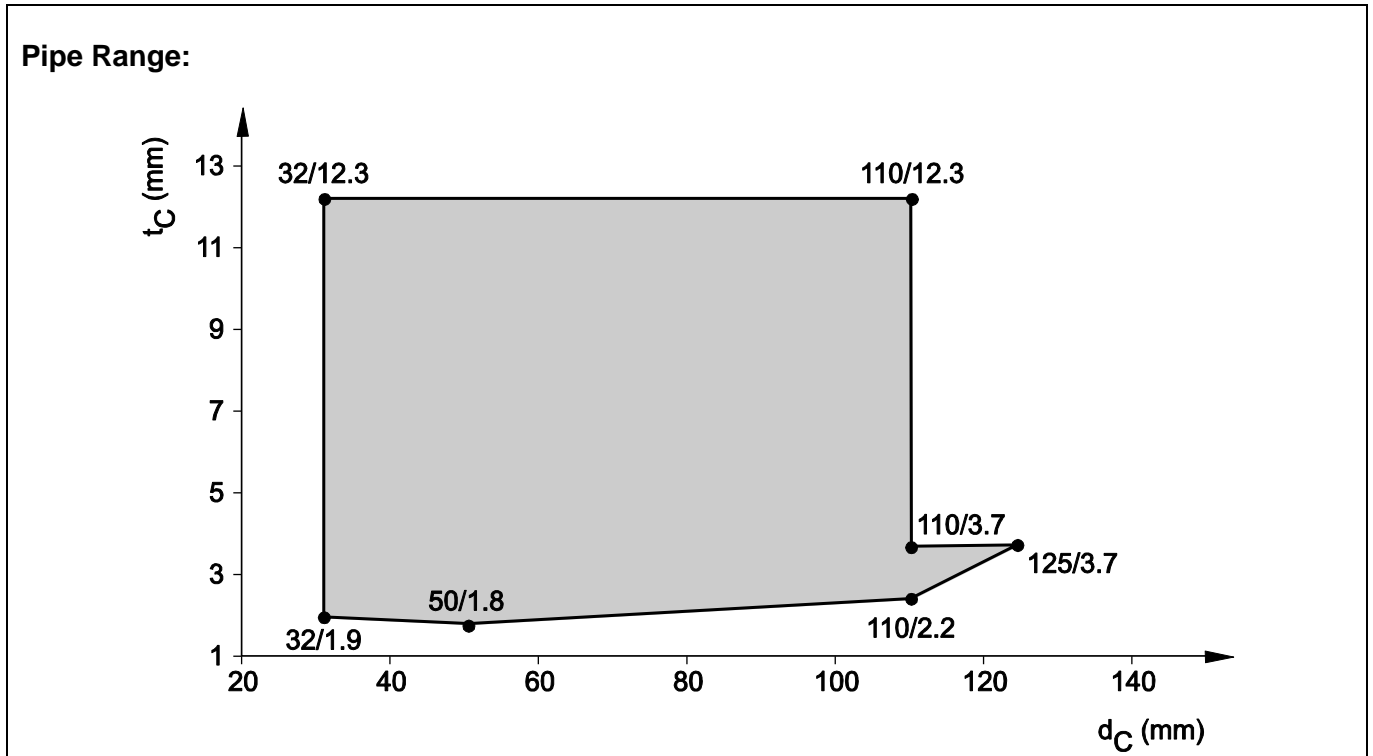

8.3.2.9 PP pipes, non-regulated in flexible wall ($t_E \geq 100$ mm), pipe group 1, EI 90 - U/U

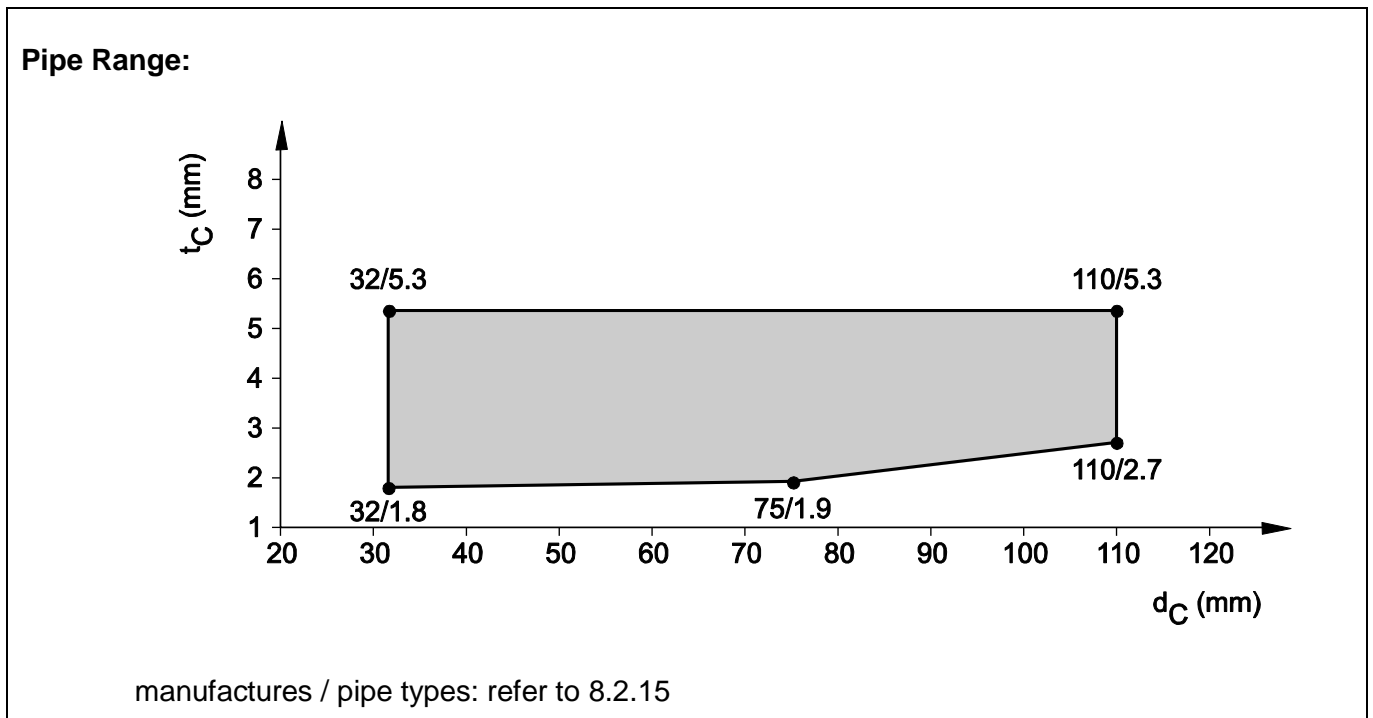

8.3.2.10 PP pipes acc. EN 1451-1 and DIN 8077/78, in flexible wall ($t_E \geq 100$ mm), pipe group 1, EI 120 - U/U

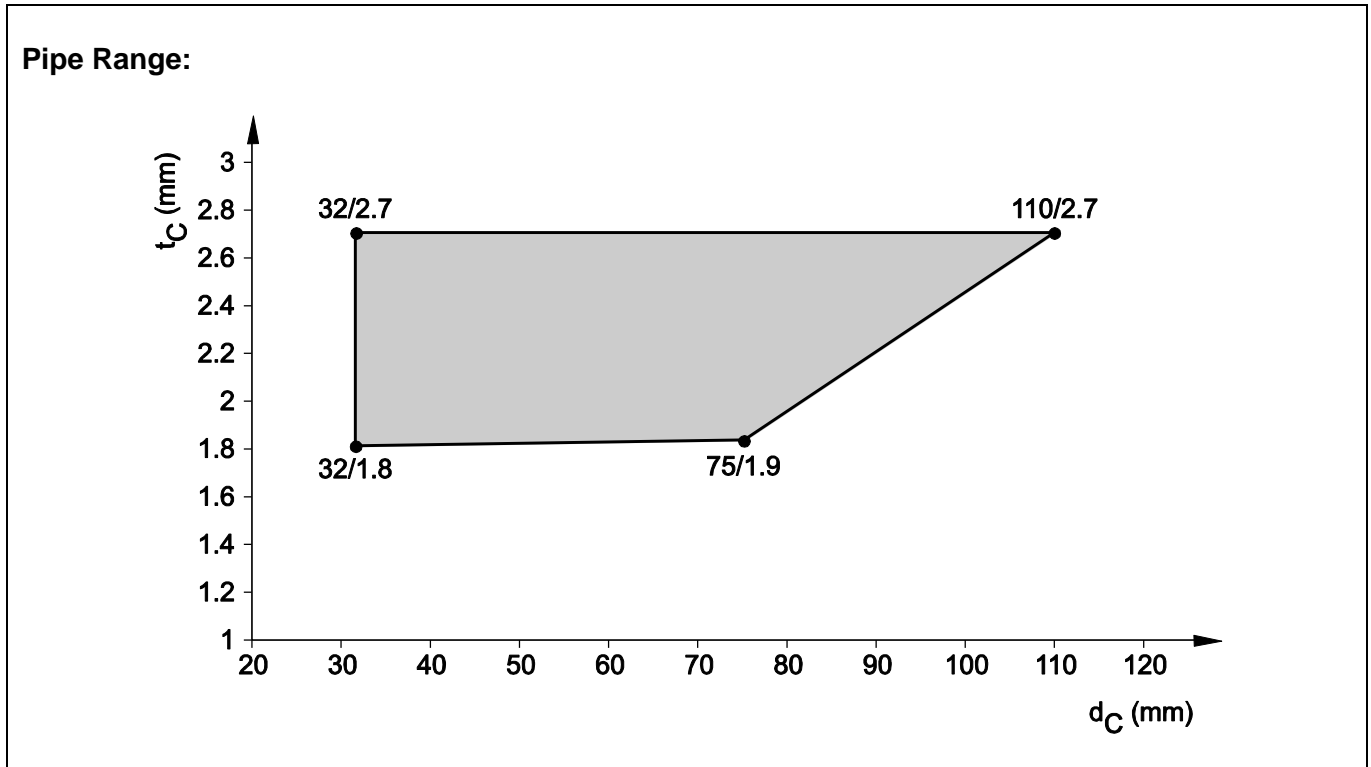

8.3.2.11 PP pipes acc. EN 1451-1 and DIN 8077/78, in flexible wall ($t_E \geq 100$ mm), pipe group 1, EI 120 - U/C

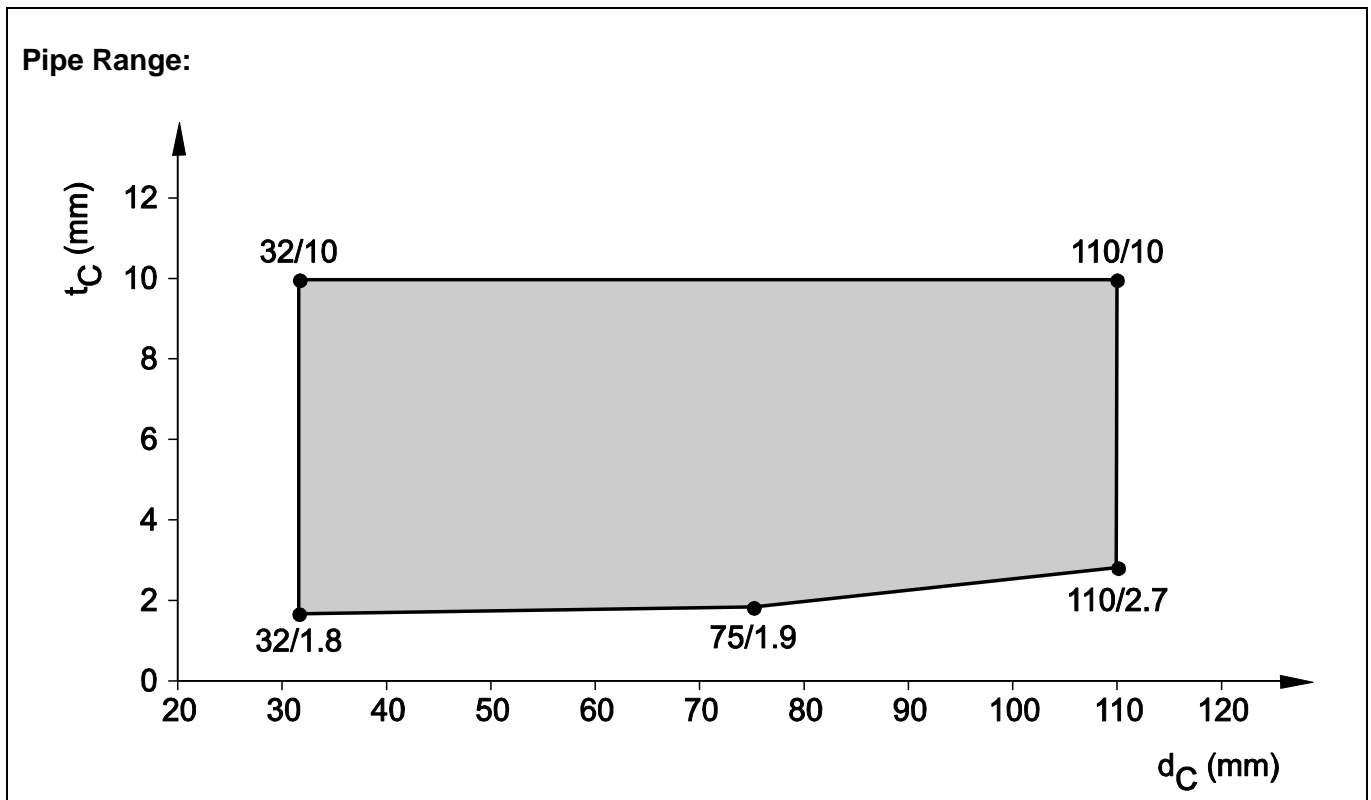

8.3.2.12 PE pipes, non-regulated (Geberit Silent dB20), in flexible wall ($t_E \geq 100$ mm), pipe group 1, EI 120 - U/U

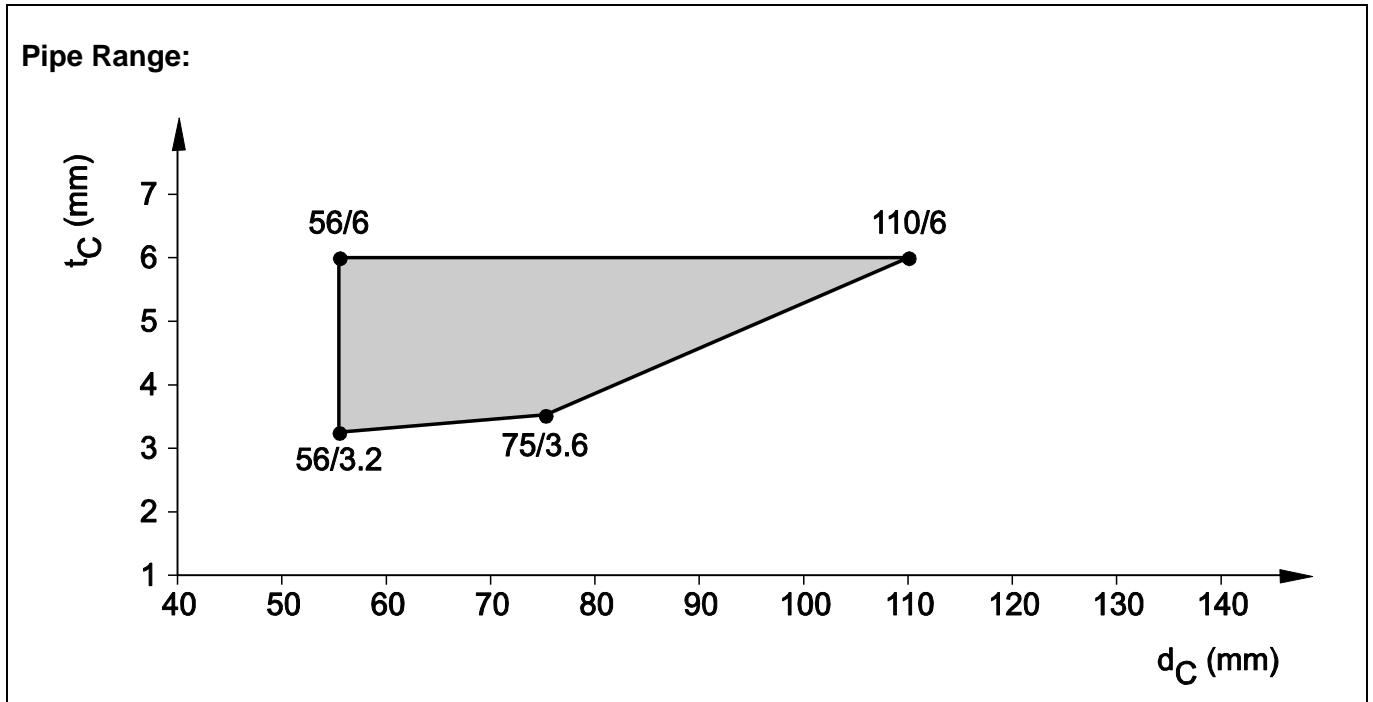

8.3.2.13 PVC-pipes, non-regulated (Friatec Friaphon), in flexible wall ($t_E \geq 100$ mm), pipe group 1, EI 90 - U/U

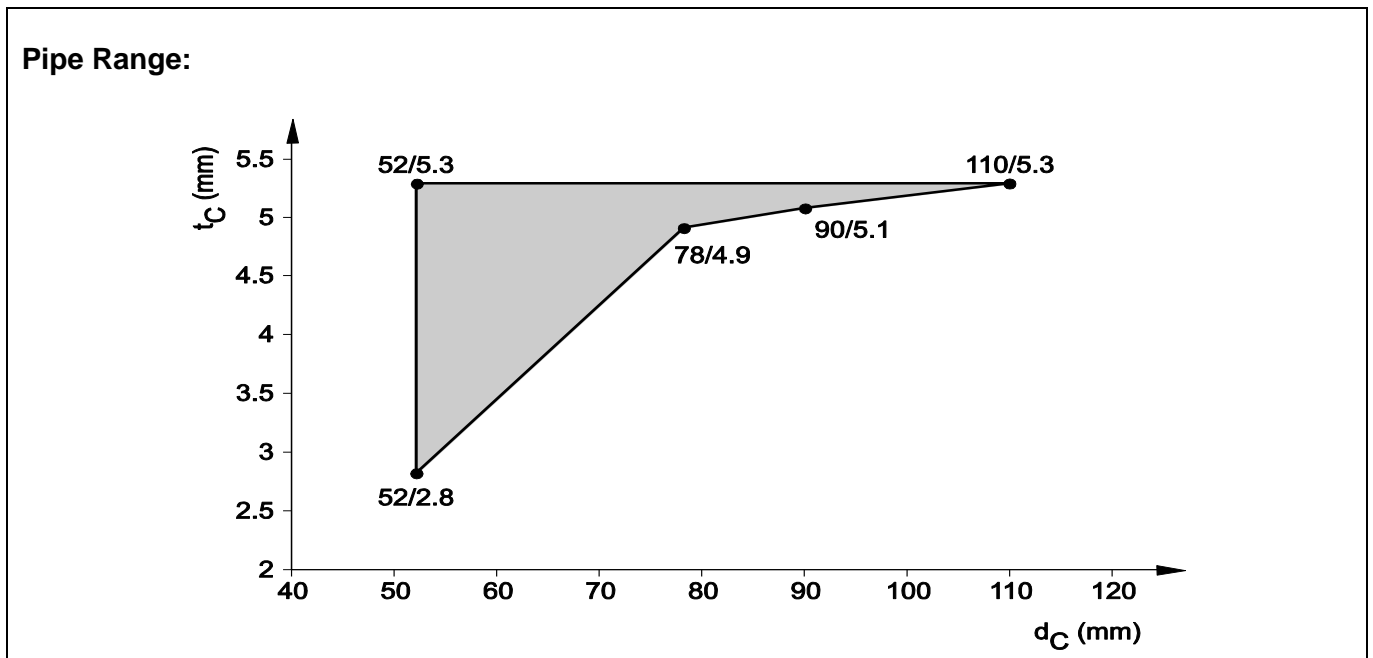

8.3.2.14 **Pneumatic dispatch system, PVC pipe acc. DIN 6660, in flexible wall ($t_E \geq 100$ mm), pipe group 1, EI 90 - U/U**

Situation for EI 90 - U/U:

- PVC pipe acc. DIN 6660
- Pipe diameter ($d_C = 110$ mm)
- Pipe wall thickness ($t_C = 2,3$ mm)
- Pipe inclination: ($45^\circ \leq \text{inclination} \leq 90^\circ$)
- Mixed penetration is allowed: pipe together with maximum three cables, see below

Maximum cable size:

- NYM-J 3x2,5 mm²
- J-Y (St) Y 6 x 2 x 0,6 mm²
- 2 x 2,5 mm²

Cable in direct contact to pipe, single or bunched cables tested

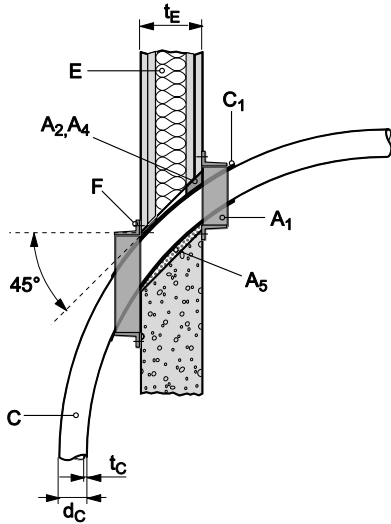

8.3.2.15 PE-X pipe acc. EN 15875 (Rehau Rautitan flex), in flexible wall ($t_E \geq 100$ mm), pipe group 1, EI 120 - U/C

Situation for EI 120 - U/C:

- PE-X acc. EN 15875 (Rehau Rautitan flex)
- Pipe diameter ($16 \text{ mm} \leq d_C \leq 32 \text{ mm}$)
- Pipe wall thickness ($2,2 \text{ mm} \leq t_C \leq 4,4 \text{ mm}$)
- Pipe inclination: 90°

Flexible, elastomeric thermal insulation D_E :

- Type of material: refer to 8.2.12
- Thickness of D_E : ($9 \text{ mm} \leq t_D \leq 25 \text{ mm}$)
- Insulation length: ($L_D \geq 250 \text{ mm}$) on pipes on both sides of the wall
- LS and CS situation

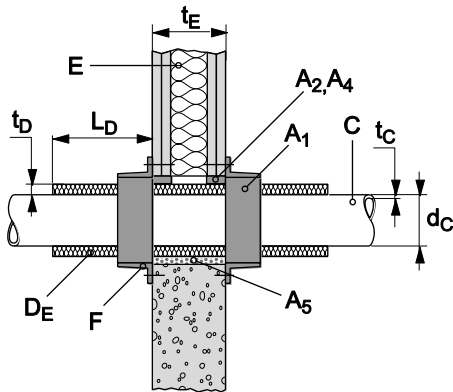

8.3.2.16 PP-R pipe acc. EN 15874 (Aquatherm fusiolen = aquatherm green pipe S), in flexible wall ($t_E \geq 100$ mm), pipe group 1, EI 120 - U/C

Situation for EI 120 - U/C:

- PP-R acc. EN 15874 (Aquatherm fusiolen = aquatherm green pipe S),
- Pipe diameter ($16 \text{ mm} \leq d_C \leq 32 \text{ mm}$)
- Pipe wall thickness ($2,2 \text{ mm} \leq t_C \leq 4,4 \text{ mm}$)
- Pipe inclination: 90°

Flexible, elastomeric thermal insulation D_E :

- Type of material: refer to 8.2.12
- Thickness of D_E : ($9 \text{ mm} \leq t_D \leq 25 \text{ mm}$)
- Insulation length: ($L_D \geq 250 \text{ mm}$) on pipes on both sides of the wall
- LS and CS situation

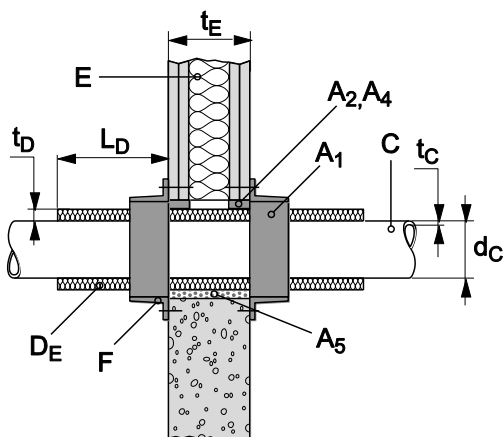

8.3.2.17 **PP pipes, non-regulated, in flexible wall ($t_E \geq 100$ mm), pipe group 1, EI 120 - U/U, Pipe coupling**

Situation for EI 120 - U/U:

- Pipe coupling inside the wall, half in the wall or outside the wall
- Type of pipes: refer to 8.2.15
- Range of pipes: refer to 8.3.2.9
- Gap filler: Hilti CFS-FIL
- Annular Gap: 5 - 40 mm
- Depth t_{A3} to be filled with Hilti CFS-FIL: ($t_{A3} \geq 25$ mm)

Backfilling:

- In drywall no backfilling required
- In rigid wall backfilling with mineral wool, refer to Annex 2, chapter 7.2

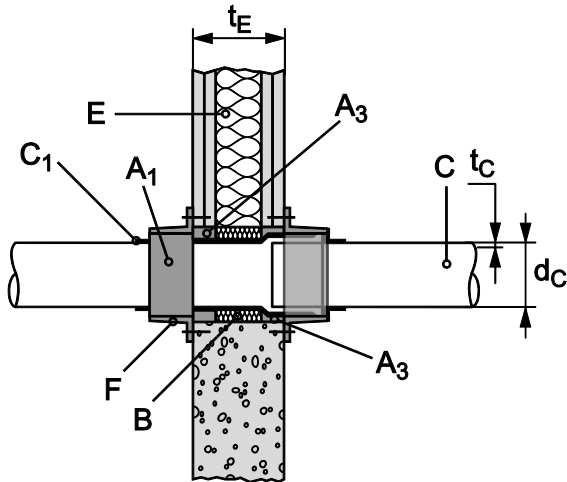

Requested number of hooks on CFS-C EL to seal pipes, penetrating a flexible wall/ rigid wall ($t_E \geq 100$ mm) and using a linear pipe coupling. (no elbow). If pipe insulation thickness is between 0 and 4 mm use the number of hooks indicated for 4 mm. If pipe insulation thickness is between 4 and 9 mm use the number of hooks indicated for 9 mm.

Pipe outside nominal diameter d_C (mm)	Acoustic Pipe Insulation Thickness t_D (mm) (incoming pipe / outgoing pipe)		
	0	4	9
32	2 / 2	2 / 2	2 / 2
50	2 / 2	2 / 2	2 / 3
75	3 / 3	3 / 3	3 / 3
90	3 / 3	3 / 3	3 / 3
110	3 / 4	3 / 4	3 / 4

8.3.2.18 **PP pipes, non-regulated, in flexible wall ($t_E \geq 100$ mm), pipe group 1, EI 90 - U/U, Elbow Pipes 87°**

Situation for EI 90 - U/U:

- Elbow Pipe 87° inside the wall, half in the wall or outside the wall, covered by CFS-C EL
- Type of pipes: refer to 8.2.15
- Range of pipes: refer to 8.3.2.9
- On one side the pipe may run with zero distance to penetrated wall ($s_3 \geq 0$ mm)

Gap size and gap filler:

In flexible wall application ($t_E \geq 100$ mm):

- Gap filler: Hilti CFS-S ACR or gypsum
- Annular gap: 0 – 15 mm
- Depth t_{A2} to be filled with Hilti CFS-S ACR or gypsum: ($t_{A2} \geq 25$ mm)
- No backfilling required

In rigid wall application ($t_E \geq 100$ mm):

- Gap filler: Hilti CFS-S ACR
 - Annular gap: 0 – 15mm
 - Depth t_{A2} to be filled with Hilti CFS-S ACR: ($t_{A2} \geq 25$ mm)
 - No backfilling required
- or:
- Gap filler: cementious Mortar M10 acc. EN 998-2
 - Annular gap: 0 – 40mm
 - Depth to be filled with cementious Mortar M10: to fill over entire wall thickness

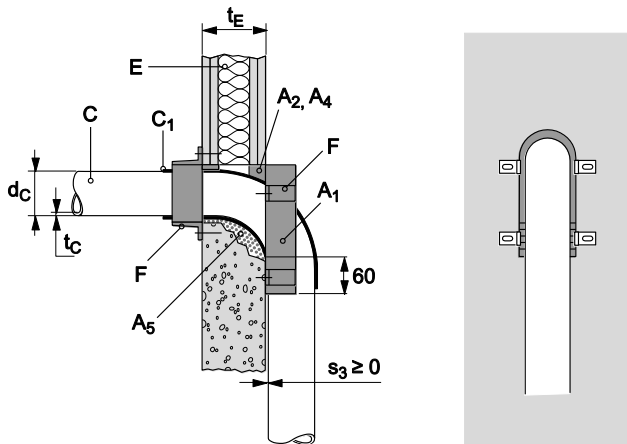

Requested number of hooks:

Pipe outside nominal diameter d_c (mm)	Acoustic Pipe Insulation Thickness t_D (mm) (no elbow side - horizontal running pipe / elbow side - vertical running pipe)		
	0	4	9
32	2 / 2	2 / 2	2 / 2
50	2 / 2	2 / 2	2 / 3
75	3 / 3	3 / 3	3 / 3
90	3 / 3	3 / 3	3 / 3
110	3 / 4	3 / 4	3 / 4

If pipe insulation thickness is between 0 and 4mm use the number of hooks indicated for 4 mm.
 If pipe insulation thickness is between 4 and 9 mm use the number of hooks indicated for 9 mm.

8.3.2.19 PP pipes, non-regulated, in flexible wall ($t_E \geq 100$ mm) pipe group 1, EI 60 - U/U, Pipe coupling

Situation for EI 60 - U/U:

- Pipe coupling inside the wall, half in the wall or outside the wall, covered by CFS-C EL
- Type of pipes: refer to 8.2.15
- Range of pipes: refer to 8.3.2.9

Gap size and gap filler:

In flexible wall application ($t_E \geq 100$ mm):

- Gap filler: Hilti CFS-S ACR or gypsum
- Annular gap: 0 – 15 mm
- Depth t_{A2} to be filled with Hilti CFS-S ACR or gypsum: ($t_{A2} \geq 25$ mm)
- No backfilling required

In rigid wall application ($t_E \geq 100$ mm):

- Gap filler: Hilti CFS-S ACR
 - Annular gap: 0 – 15 mm
 - Depth t_{A2} to be filled with Hilti CFS-S ACR: ($t_{A2} \geq 25$ mm)
 - No backfilling required
- or:
- Gap filler: cementious Mortar M10 acc. EN 998-2
 - Annular gap: 0 – 40 mm
 - Depth to be filled with cementious Mortar M10: to fill over entire wall thickness

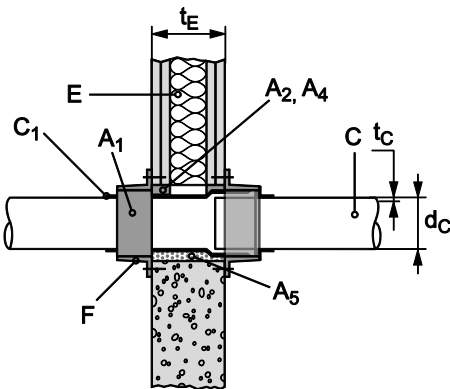

Requested number of hooks:

Pipe outside nominal diameter d_c (mm)	Acoustic Pipe Insulation Thickness t_D (mm)		
	(incoming pipe / outgoing pipe)		
	0	4	9
32	2 / 2	2 / 2	2 / 2
50	2 / 2	2 / 2	2 / 3
75	3 / 3	3 / 3	3 / 3
90	3 / 3	3 / 3	3 / 3
110	3 / 4	3 / 4	3 / 4

If pipe insulation thickness is between 0 and 4 mm use the number of hooks indicated for 4 mm.
 If pipe insulation thickness is between 4 and 9 mm use the number of hooks indicated for 9 mm.

8.3.2.20 PP pipes, non-regulated, in flexible wall ($t_E \geq 100$ mm), pipe group 1, EI 60 - U/U, 2x45° Elbow Pipes

Situation for EI 60 - U/U:

- 2x45° Elbow Pipes, inside the wall, half in the wall or outside the wall, covered by CFS-C EL
- Type of pipes: refer to 8.3.15
- Range of pipes: refer to 8.3.2.9
- On one side of the wall pipe runs parallel to wall with zero distance ($s_3 \geq 0$ mm)

Gap size and gap filler:

In flexible wall application ($t_E \geq 100$ mm):

- Gap filler: Hilti CFS-S ACR or gypsum
- Annular gap: 0 – 15 mm
- Depth t_{A2} to be filled with Hilti CFS-S ACR or gypsum: ($t_{A2} \geq 25$ mm)
- No backfilling required

In rigid wall application ($t_E \geq 100$ mm):

- Gap filler: Hilti CFS-S ACR
 - Annular gap: 0 – 15 mm
 - Depth t_{A2} to be filled with Hilti CFS-S ACR: ($t_{A2} \geq 25$ mm)
 - No backfilling required
- or:
- Gap filler: cementious Mortar M10 acc. EN 998-2
 - Annular gap: 0 – 40 mm
 - Depth to be filled with cementious Mortar M10: to fill over entire wall thickness

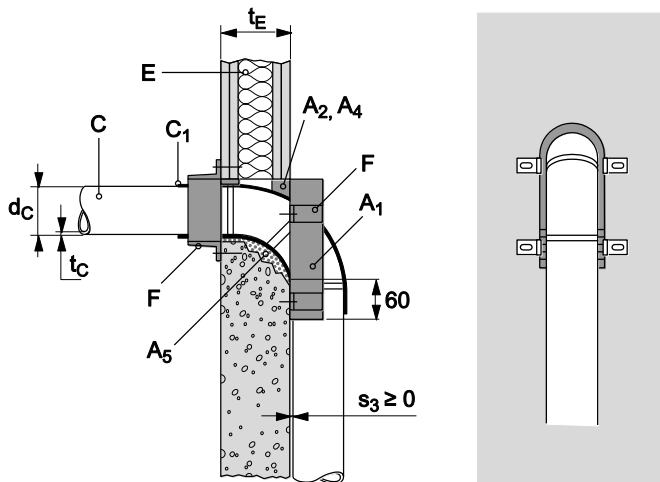

Requested number of hooks:

Pipe outside nominal diameter d_c (mm)	Acoustic Pipe Insulation Thickness t_D (mm) (no elbow side - horizontal running pipe / elbow side - vertical running pipe)		
	0	4	9
32	2 / 2	2 / 2	2 / 2
50	2 / 2	2 / 2	2 / 3
75	3 / 3	3 / 3	3 / 3
90	3 / 3	3 / 3	3 / 3
110	3 / 4	3 / 4	3 / 4

If pipe insulation thickness is between 0 and 4 mm use the number of hooks indicated for 4 mm.
 If pipe insulation thickness is between 4 and 9 mm use the number of hooks indicated for 9 mm.

8.3.2.21 Pipes, in flexible wall ($t_E \geq 100$ mm), pipe group 1, EI 90 - U/U, inclined Pipes 45°

Situation for EI 90 - U/U:

- Pipe inclination ($45^\circ \leq \text{inclination} \leq 90^\circ$)
 - Type of pipes: refer to 8.3.2.1; 8.3.2.2; 8.3.2.4; 8.3.2.5; 8.3.2.8; 8.3.2.9; 8.3.2.10; 8.3.2.12
 - Range of pipes: refer to 8.3.2.1; 8.3.2.2; 8.3.2.4; 8.3.2.5; 8.3.2.8; 8.3.2.9; 8.3.2.10; 8.3.2.12
- Excluded are only pipes with an outside nominal diameter ($d_c \geq 110$ mm)

Gap size and gap filler:

In flexible wall application ($t_E \geq 100$ mm):

- Gap filler: Hilti CFS-S ACR or gypsum
- Annular gap: 0 – 15 mm
- Depth t_{A2} to be filled with Hilti CFS-S ACR or gypsum: ($t_{A2} \geq 25$ mm)
- No backfilling required

In rigid wall application ($t_E \geq 100$ mm):

- Gap filler: Hilti CFS-S ACR
- Annular gap: 0 – 15 mm
- Depth t_{A2} to be filled with Hilti CFS-S ACR: ($t_{A2} \geq 25$ mm)
- No backfilling required
- or:
- Gap filler: cementious Mortar M10 acc. EN 998-2
- Annular gap: 0 – 40 mm
- Depth to be filled with cementious Mortar M10: to fill over entire wall thickness

Requested number of hooks:

Pipe outside nominal diameter d_c (mm)	Acoustic Pipe Insulation Thickness t_D (mm) <small>(identical on both sides of the flexible wall/rigid wall)</small>		
	0	4	9
32	3	3	3
50	3	3	3
75	3	4	4
90	4	4	5
110	5	5	5

If pipe insulation thickness is between 0 and 4 mm use the number of hooks indicated for 4 mm.
 If pipe insulation thickness is between 4 and 9 mm use the number of hooks indicated for 9 mm.

8.3.2.22 Zero distance CFS-C EL to mineral wool insulated pipes

8.3.2.22.1 Pipes in in flexible wall ($t_E \geq 100$ mm), pipe group 1, EI 90, zero distance Collar to mineral wool insulation on metal pipes

Situation for EI 90 - U/U:

- Collar CFS-C EL on plastic pipe in direct contact to mineral wool insulation ($s_1 \geq 0$ mm), used as thermal insulation on metal pipes.
 - Type of pipes: refer to 8.3.2.1; 8.3.2.2; 8.3.2.4; 8.3.2.5; 8.3.2.8; 8.3.2.9; 8.3.2.10; 8.3.2.12
 - Range of pipes: refer to 8.3.2.1; 8.3.2.2; 8.3.2.4; 8.3.2.5; 8.3.2.8; 8.3.2.9; 8.3.2.10; 8.3.2.12
- Excluded are only pipes with an outside nominal diameter ($d_C \geq 110$ mm).

Mineral wool based thermal insulation:

- Used types of Insulation: refer to 8.2.10.1

Pipes diameter ($d_M \leq 42$ mm):

- Insulation thickness ($t_D \geq 19$ mm) within the flexible wall ($t_E = L_D$)
- Insulation thickness ($t_D \geq 20$ mm) on metal pipes on both sides of the wall
- Insulation length $L_D \geq 1000$ mm on both sides of the wall
- LS situation

Pipes diameter (42 mm $< d_M \leq 89$ mm):

- Insulation thickness ($t_D \geq 19$ mm) within the flexible wall ($t_E = L_D$)
- Insulation thickness ($t_D \geq 30$ mm) on metal pipes on both sides of the wall
- Insulation length $L_D \geq 1000$ mm on both sides of the wall
- LS situation

Metal pipes, insulated by named above types of mineral wool products:

- Pipe diameter ($d_M \leq$ of 89 mm), C/U end configuration
- Pipe wall thickness of ($1,2$ mm $\leq t_M \leq 14,2$ mm)
- Covered material types– refer to 8.2.11.

Gap size and gap filler:

In flexible wall application ($t_E \geq 100$ mm):

- Gap filler: Hilti CFS-S ACR or gypsum
- Annular gap: 0 – 15 mm
- Depth t_{A2} to be filled with Hilti CFS-S ACR or gypsum: ($t_{A2} \geq 25$ mm)
- No backfilling required

In rigid wall application ($t_E \geq 100$ mm):

- Gap filler: Hilti CFS-S ACR
 - Annular gap: 0 – 15 mm
 - Depth t_{A2} to be filled with Hilti CFS-S ACR: ($t_{A2} \geq 25$ mm)
 - no backfilling required
- or:
- Gap filler: cementious Mortar M10 acc. EN 998-2
 - Annular gap: 0 – 40 mm
 - Depth to be filled with cementious Mortar M10: to fill over entire wall thickness

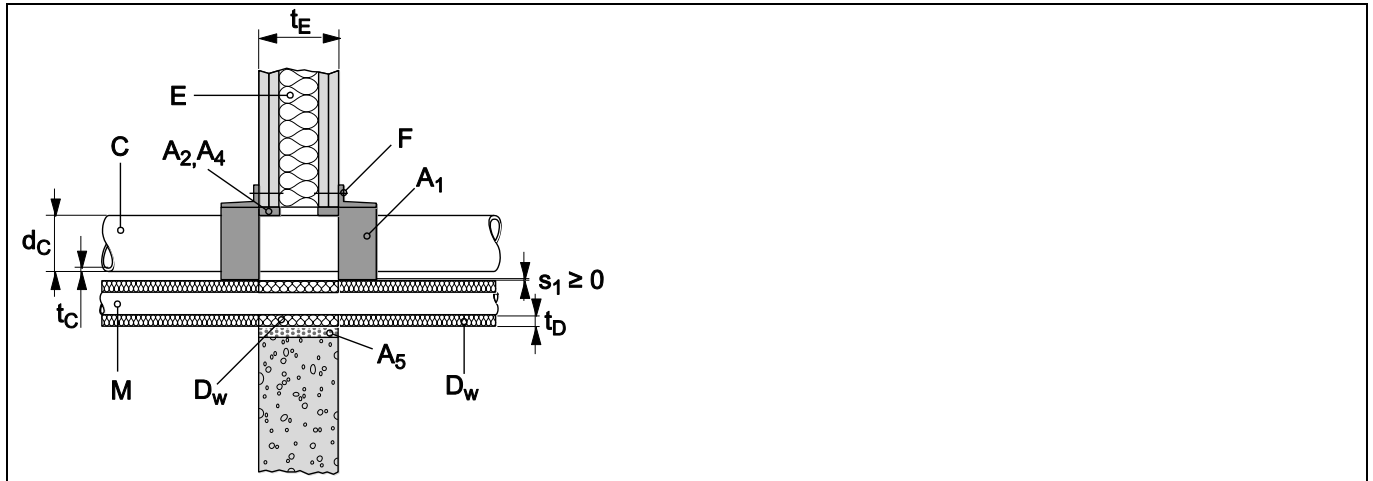

8.3.2.22.2 Pipes in flexible wall ($t_E \geq 100$ mm), pipe group 1, EI 90, zero distance Collar to mineral wool insulation on metal pipes

Situation for EI 90 - U/U:

- Collar CFS-C EL on plastic pipe in direct contact to mineral wool insulation ($s_1 \geq 0$ mm), used as thermal insulation on metal pipes
- Type of pipes: refer to 8.3.2.1; 8.3.2.2; 8.3.2.4; 8.3.2.5; 8.3.2.8; 8.3.2.9; 8.3.2.10; 8.3.2.12
- Range of pipes: refer to 8.3.2.1; 8.3.2.2; 8.3.2.3, 8.3.2.4; 8.3.2.5; 8.3.2.8; 8.3.2.9; 8.3.2.10; 8.3.2.12

Excluded are only pipes with an outside nominal diameter ($d_C \geq 110$ mm).

Mineral wool based thermal insulation:

- Used types of Insulation: refer to 8.2.10.1

Pipes diameter ($d_M \leq 42$ mm):

- Insulation thickness ($t_D \geq 19$ mm) within the flexible wall ($t_E = L_D$)
- Insulation thickness ($t_D \geq 20$ mm) on metal pipes on both sides of the wall
- Insulation length $L_D \geq 1000$ mm on both sides of the wall
- LS situation

Pipes diameter ($42 \text{ mm} < d_M \leq 114,3$ mm):

- Insulation thickness ($t_D \geq 30$ mm) within the flexible wall ($t_E = L_D$)
- Insulation thickness ($t_D \geq 30$ mm) on metal pipes on both sides of the wall
- Insulation length $L_D \geq 1000$ mm on both sides of the wall
- LS situation

Metal pipes, insulated by named above types of mineral wool products:

- Pipe diameter ($d_M \leq 114,3$ mm), C/U end configuration
- Pipe wall thickness of ($1,2 \text{ mm} \leq t_M \leq 14,2$ mm)
- Covered material types – refer to 8.2.11, excluded material is copper

Gap size and gap filler:

In flexible wall application ($t_E \geq 100$ mm):

- Gap filler: Hilti CFS-S ACR or gypsum
- Annular gap: 0 – 15 mm
- Depth t_{A2} to be filled with Hilti CFS-S ACR or gypsum: ($t_{A2} \geq 5$ mm)
- No backfilling required

In rigid wall application ($t_E \geq 100$ mm):

- Gap filler: Hilti CFS-S ACR
- Annular gap: 0 – 15 mm
- Depth t_{A2} to be filled with Hilti CFS-S ACR: ($t_{A2} \geq 25$ mm)
- no backfilling required
- or:
- Gap filler: Hilti CFS-S ACR
- Annular gap: 0 – 40 mm
- Depth t_{A2} to be filled with Hilti CFS-S ACR: ($t_{A2} \geq 25$ mm)
- Back filled with mineral wool, refer to Annex 2, chapter 7.2
- or:
- Gap filler: cementious Mortar M10 acc. EN 998-2
- Annular gap: 0 – 40 mm
- Depth to be filled with cementious Mortar M10: to fill over entire wall thickness

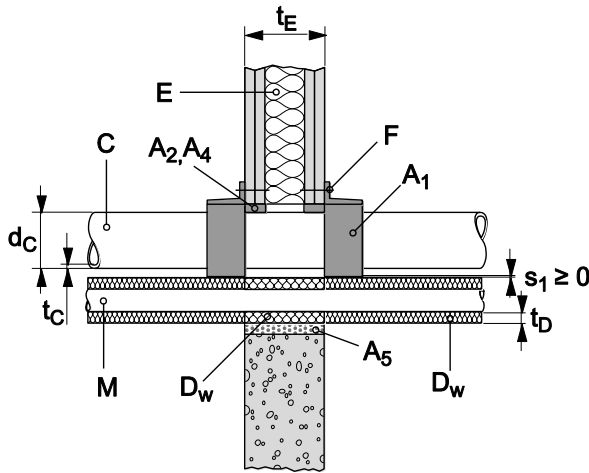

8.3.2.22.3 Pipes in flexible wall ($t_E \geq 100$ mm), pipe group 1, EI 90, zero distance collar to mineral wool insulation on aluminum composite pipes

Situation for EI 90 - U/U (refer to 8.2.10.2):

- Collar CFS-C EL on plastic pipe in direct contact to mineral wool insulation ($s_1 \geq 0$ mm), used as thermal insulation on aluminum composite pipes.
- Type of pipes: refer to 8.3.2.1; 8.3.2.2; 8.3.2.4; 8.3.2.5; 8.3.2.8; 8.3.2.9; 8.3.2.10; 8.3.2.12
- Range of pipes: refer to 8.3.2.1; 8.3.2.2; 8.3.2.3; 8.3.2.4; 8.3.2.5; 8.3.2.8; 8.3.2.9; 8.3.2.10; 8.3.2.12

Excluded are only pipes with an outside nominal diameter ($d_c > 110$ mm).

Mineral wool based thermal insulation

- Used types of Insulation: refer to 8.2.10.2
- Insulation thickness ($t_D \geq 20$ mm and ≤ 60 mm)
- Insulation length $L_D \geq 1000$ mm
- LS situation

Aluminum composite pipes, insulated by named above types of mineral wool products:

- See table below

Gap size and gap filler:

In flexible wall application ($t_E \geq 100$ mm):

- Gap filler: Hilti CFS-S ACR or gypsum
- Annular gap: 0 – 15 mm
- Depth t_{A2} to be filled with Hilti CFS-S ACR or gypsum: ($t_{A2} \geq 25$ mm)
- No backfilling required

In rigid wall application ($t_E \geq 100$ mm):

- Gap filler: Hilti CFS-S ACR
- Annular gap: 0 – 15 mm
- Depth t_{A2} to be filled with Hilti CFS-S ACR: ($t_{A2} \geq 25$ mm)
- no backfilling required
- or:
- Gap filler: Hilti CFS-S ACR
- Annular gap: 0 – 40 mm
- Depth t_{A2} to be filled with Hilti CFS-S ACR: ($t_{A2} \geq 25$ mm)
- Back filled with mineral wool, refer to Annex 2, chapter 7.2
- or:
- Gap filler: cementious Mortar M10 acc. EN 998-2
- Annular gap: 0 – 40 mm
- Depth to be filled with cementious Mortar M10: to fill over entire wall thickness

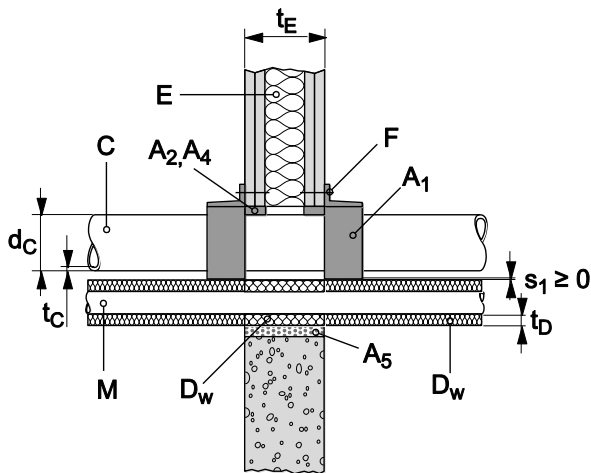

Aluminum composite pipes EI90 U/C

Pipe Ø (mm)	Wall thickness (mm)	Pipe Insulation		
		Type	Thickness (mm)	Configuration (---)
Geberit Mepla – material: PE-Xb/Al/PE-Xb				
16 - 63	2,25 - 4,5	Mineral wool	20 - 60	LS
Kekelit Kelox – material: PE-RT/Al/PE-RT				
16 - 63	2,0 - 6,0	Mineral wool	20 - 60	LS
Rehau Rautitan Flex – material: PE-Xa – standard: EN 151875				
16 - 63	2,2 – 8,6	Mineral wool	20 - 60	LS

TECEflex Verbundrohr – material: PE-Xc/Al/PE				
16 - 63	2,75 – 6,0	Mineral wool	20 - 60	LS
Uponor Unipipe MLC – material: PE-RT/Al/PE-RT				
16 - 63	2,0 - 6,0	Mineral wool	20 - 60	LS
Uponor Unipipe Plus – material: PE-RT/Al/PE-RT				
16 - 32	2,0 – 3,0	Mineral wool	20 - 60	LS
Viega Raxofix – material: PE-Xc/Al/PE-Xc				
16 - 63	2,2 – 4,5	Mineral wool	20 - 60	LS
Wavin Tigris – material: PE-Xc/Al/PE				
16 - 63	2,0 – 6,0	Mineral wool	20 - 60	LS

8.3.2.23 Zero distance CFS-C EL to combustible insulated pipes covered with CFS-B

8.3.2.23.1 Pipes in flexible wall ($t_E \geq 100$ mm), pipe group 1, EI 90, zero distance between CFS-C EL collar and CFS-B, wrapped around an elastomeric foamed thermal insulation on metal pipe

Situation for EI 90 - U/U (refer to 8.2.10.3):

- Zero distance between CFS-C EL collar and CFS-B, wrapped around an elastomeric foamed thermal insulation on metal pipe ($s_1 \geq 0$ mm)
- Type of pipes: refer to 8.3.2.1; 8.3.2.2; 8.3.2.3, 8.3.2.4; 8.3.2.5; 8.3.2.8; 8.3.2.9; 8.3.2.10; 8.3.2.12
- Range of pipes: refer to 8.3.2.1; 8.3.2.2; 8.3.2.3, 8.3.2.4; 8.3.2.5; 8.3.2.8; 8.3.2.9; 8.3.2.10; 8.3.2.12

Excluded are only pipes with outside nominal diameter ($d_c \geq 110$ mm)

- An additional protect insulation D_P has to be wrapped around CFS-B and elastomeric insulation D_E below

Flexible, elastomeric thermal insulation D_E :

- Type of material: refer to 8.2.12
- Thickness of D_E : ($9 \text{ mm} \leq t_D \leq 35 \text{ mm}$)
- CS situation

Additional protect insulation D_P :

- Type of material: refer to 8.2.12, always same as D_E
- Thickness of D_P : ($t_D \geq 19$ mm)
- Insulation length: ($L_D \geq 250$ mm) on pipes on both sides of the wall
- LI situation

Metal pipes:

- Pipe diameter ($15 \text{ mm} \leq 42 \text{ mm}$), C/U end configuration
- Pipe wall thickness of ($1 \text{ mm} \leq t_M \leq 14,2 \text{ mm}$)
- Covered material types for metal pipes – refer to 8.2.11.

Gap size and gap filling:

Gap filling in flexible wall application ($t_E \geq 100$ mm):

- Gap filler: Hilti CFS-S ACR or gypsum
- Annular Gap: 0 – 15 mm
- Depth t_{A2} to be filled with Hilti CFS-S ACR or gypsum: ($t_{A2} \geq 25$ mm)
- No backfilling required

Gap filling in rigid wall application ($t_E \geq 100$ mm):

- Gap filler: Hilti CFS-S ACR
- Annular gap: 0 – 15 mm
- Depth t_{A2} to be filled with Hilti CFS-S ACR: ($t_{A2} \geq 25$ mm)
- No backfilling required
- or:
- Gap filler: cementious Mortar M10 acc. EN 998-2
- Annular gap: 0 – 40 mm
- Depth to be filled with cementious Mortar M10: to fill over entire wall thickness
- or:
- Gap filler: Hilti CFS-S ACR
- Annular gap: 0 – 40 mm
- Depth t_{A2} to be filled with Hilti CFS-S ACR: ($t_{A2} \geq 25$ mm)
- Back filled with mineral wool, refer to Annex 2, chapter 7.2

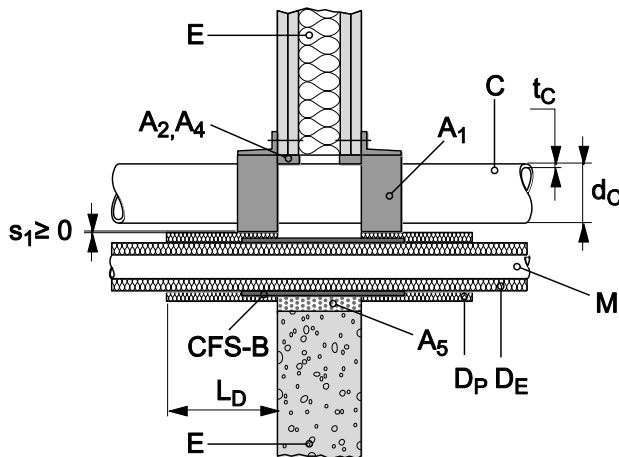

8.3.2.23.2 Pipes in flexible wall ($t_E \geq 100$ mm), pipe group 1, EI 90, zero distance between CFS-C EL collar and CFS-B, wrapped around an elastomeric foamed thermal insulation on metal pipe

Situation for EI 90 - U/U (refer to 8.2.10.3):

- Zero distance between CFS-C EL collar and CFS-B, wrapped around an elastomeric foamed thermal insulation on steel pipe ($s_1 \geq 0$ mm)
 - Type of pipes: refer to 8.3.2.1; 8.3.2.2; 8.3.2.4; 8.3.2.5; 8.3.2.8; 8.3.2.9; 8.3.2.10; 8.3.2.12
 - Range of pipes: refer to 8.3.2.1; 8.3.2.2; 8.3.2.4; 8.3.2.5; 8.3.2.8; 8.3.2.9; 8.3.2.10; 8.3.2.12
- Excluded are only pipes with outside nominal diameter ($d_c \geq 110$ mm)
- An additional protect insulation D_P has to be wrapped around CFS-B and elastomeric insulation D_E below

Flexible, elastomeric thermal insulation D_E :

- Type of material: refer to 8.2.12
- Thickness of D_E : ($9 \text{ mm} \leq t_D \leq 40,5 \text{ mm}$)
- Insulation length: ($L_D \geq 250 \text{ mm}$) on pipes on both sides of the wall
- CS situation

Additional protect insulation D_P :

- Type of material: refer to 8.2.12, always same as D_E
- Thickness of D_P : ($t_D \geq 19 \text{ mm}$)
- Insulation length: ($L_D \geq 250 \text{ mm}$) on pipes on both sides of the wall
- LI situation

Metal pipes:

- Pipe diameter ($15 \text{ mm} \leq d_M \leq 76 \text{ mm}$), C/U end configuration
- Pipe wall thickness of ($1,0 \text{ mm} \leq t_M \leq 14,2 \text{ mm}$)
- Covered material types for metal pipes – refer to 8.2.12, but excluded copper

Gap size and gap filling:

Gap filling in flexible wall application ($t_E \geq 100 \text{ mm}$):

- Gap filler: Hilti CFS-S ACR or gypsum
- Annular Gap: 0 – 15 mm
- Depth t_{A2} to be filled with Hilti CFS-S ACR or gypsum ($t_{A2} \geq 25 \text{ mm}$)
- No backfilling required

Gap filling in rigid wall application ($t_E \geq 100 \text{ mm}$):

- Gap filler: Hilti CFS-S ACR
- Annular gap: 0 – 15 mm
- Depth t_{A2} to be filled with Hilti CFS-S ACR ($t_{A2} \geq 25 \text{ mm}$)
- No backfilling required
- or:
- Gap filler: cementious Mortar M10 acc. EN 998-2
- Annular gap: 0 – 40 mm
- Depth to be filled with cementious Mortar M10: to fill over entire wall thickness
- or:
- Gap filler: Hilti CFS-S ACR
- Annular gap: 0 – 40 mm
- Depth t_{A2} to be filled with Hilti CFS-S ACR ($t_{A2} \geq 25 \text{ mm}$)
- Back filled with mineral wool, refer to Annex 2, chapter 7.2

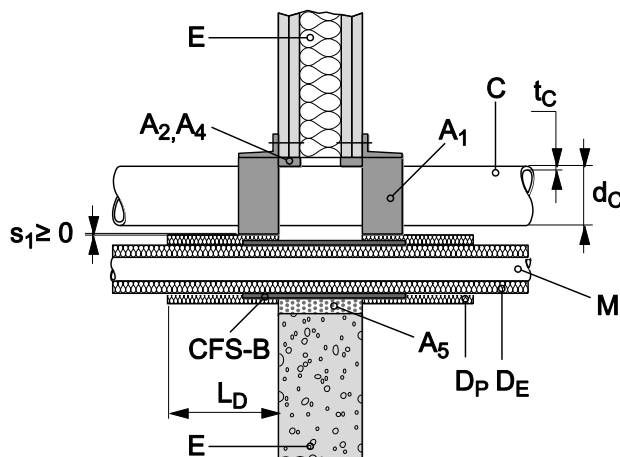

8.3.2.23.3 Pipes in flexible wall ($t_E \geq 100$ mm), pipe group 1, EI 60/90, zero distance between CFS-C EL collar and CFS-B, wrapped around an elastomeric foamed thermal insulation on aluminium composite and PP-R pipes

Situation for EI 90-U/U (refer to 3.1.11):

- Zero distance between CFS-C EL collar and CFS-B, wrapped around an elastomeric foamed thermal insulation on aluminium composite pipes ($s_1 \geq 0$ mm)
- Type of pipes: refer to 3.2.2.1; 3.2.2.2; 3.2.2.3, 3.2.2.4; 3.2.2.5; 3.2.2.8; 3.2.2.9; 3.2.2.10; 3.2.2.12
- Range of pipes: refer to 3.2.2.1; 3.2.2.2; 3.2.2.3, 3.2.2.4; 3.2.2.5; 3.2.2.8; 3.2.2.9; 3.2.2.10; 3.2.2.12

Excluded are only pipes with outside nominal diameter ($d_c \geq 110$ mm)

Flexible, elastomeric thermal insulation D_E :

- Type of material: refer to 8.2.12
- CS situation

Pipes in zero distance to CFS-C EL:

- see table below

Gap size and gap filling:

Gap filling in flexible wall application ($t_E \geq 100$ mm):

- Gap filler: Hilti CFS-S ACR or gypsum
- Annular Gap: 0 – 15 mm
- Depth t_{A2} to be filled with Hilti CFS-S ACR or gypsum ($t_{A2} \geq 25$ mm)
- No backfilling required

Gap filling in rigid wall application ($t_E \geq 100$ mm):

- Gap filler: Hilti CFS-S ACR
- Annular gap: 0 – 15 mm
- Depth t_{A2} to be filled with Hilti CFS-S ACR ($t_{A2} \geq 25$ mm)
- No backfilling required
- or:
- Gap filler: cementious Mortar M10 acc. EN 998-2
- Annular gap: 0 – 40 mm
- Depth to be filled with cementious Mortar M10: to fill over entire wall thickness
- or:
- Gap filler: Hilti CFS-S ACR
- Annular gap: 0 – 40 mm
- Depth t_{A2} to be filled with Hilti CFS-S ACR ($t_{A2} \geq 25$ mm)
- Back filled with mineral wool, refer to Annex 2, chapter 7.2

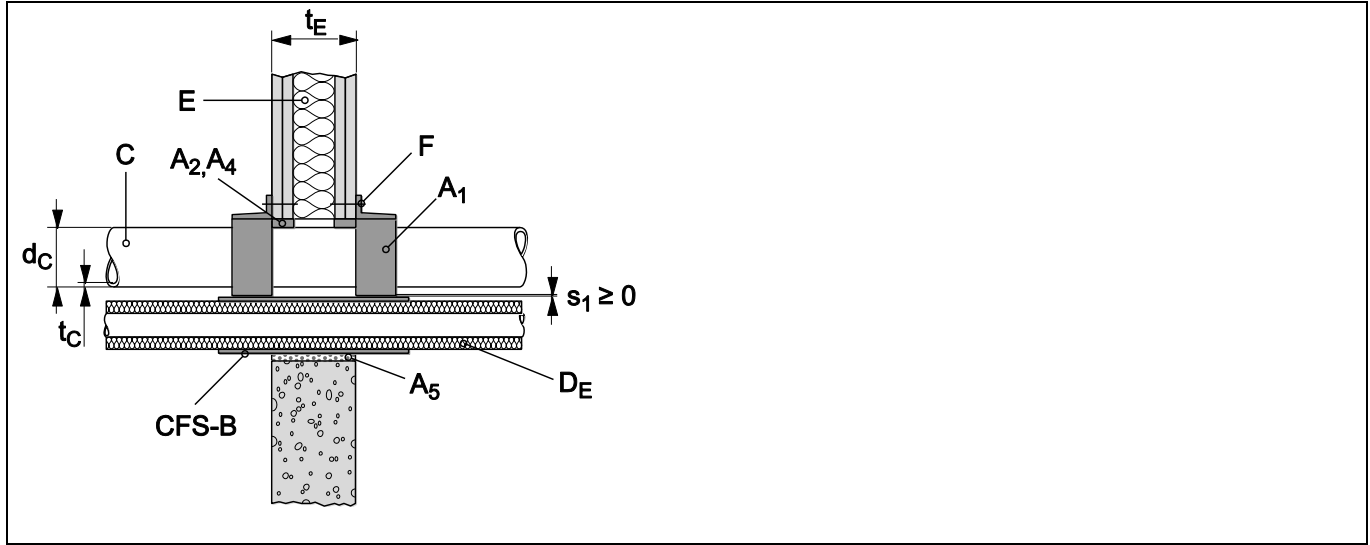

Aluminum composite pipes EI60 U/C

Pipe Ø (mm)	Wall thickness (mm)	Pipe Insulation		
		Type	Thickness (mm)	Configuration (---)
Fränkische Rohrwerke - Alpex F50 Profi – material: PE-X/Al/PE-X				
16 - 40	2,0 - 3,5	elastomeric	8,0 - 36,5	CS
Geberit Mepla – material: PE-Xb/Al/PE-Xb				
16 - 40	2,0 - 3,5	elastomeric	8,0 - 36,5	CS
Viega - SANIFIX Fosta-Rohr – material: PE-Xc/Al/PE-Xc				
16 - 40	2,2 – 3,5	elastomeric	8,0 - 36,5	CS

Aluminum composite pipes and PP-R pipes EI90 U/C

Pipe Ø (mm)	Wall thickness (mm)	Pipe Insulation		
		Type	Thickness (mm)	Configuration (---)
Aquatherm green – material: PP-R – standard: EN 15874, DIN 8077/78				
20 - 110	1,9 - 10,0	elastomeric	8,0 - 40,5	CS
Fränkische Rohrwerke - Alpex F50 Profi – material: PE-X/Al/PE-X				
16	2,0	elastomeric	8,0 - 32	CS
16 - 32	2,0 - 3,0	elastomeric	8,0 - 9,0	CS
16 - 75	2,0 - 5,0	elastomeric	32,0 - 40,5	CS

Geberit Mepla – material: PE-Xb/Al/PE-Xb				
16 - 32	2,25 - 3,5	elastomeric	8,0 - 9,0	CS
16 - 75	2,25 - 4,75	elastomeric	32,0 - 40,5	CS
Georg Fischer - Sanipex – material: PE-Xc/Al/PE-Xb				
16 - 63	2,25 - 4,5	elastomeric	9,0 - 39	CS
Kekelit Kelox – material: PE-RT/Al/PE-RT				
16 - 75	2,0 - 7,0	elastomeric	8,0 - 40,5	CS
Kekelit Ketrix – material: Cryolen Polyolefinblend (POB) – standard: EN 15847				
20 - 75	1,9 - 6,8	elastomeric	8,0 - 40,5	CS
Polo-Polymutan – material: PP-R 80 – standard: DIN 8077/78				
20 - 75	1,9/6,8 - 12,5	elastomeric	8,0 - 40,5	CS
Polo-Polymutan ML5– material: PP-R				
20 - 75	2,8 - 10,8	elastomeric	8,0 - 40,5	CS
Prineto Stabil Rohr – material: PE-Xb/Al/PE-HD				
17 - 42	2,8 - 4,6	elastomeric	8,0 - 36,5	CS
17 - 63	2,8 - 6,0	elastomeric	32,0 - 39,0	CS
Rehau Rautitan Flex – material: PE-Xa – standard: EN 151875				
16 - 63	2,2 - 8,6	elastomeric	8,0 - 39	CS
Rehau Rautitan Stabil – material: PE-Xa				
40	6,0	elastomeric	9,0 - 38,5	CS
TECEflex Verbundrohr – material: PE-Xc/Al/PE				
16 - 63	2,2 – 6,0	elastomeric	9,0 - 39	CS
Uponor Unipipe Plus – material: PE-RT/Al/PE-RT				
16 - 32	2,0 – 3,0	elastomeric	8,0 – 35,0	CS
Viega - SANIFIX Fosta-Rohr – material: PE-Xc/Al/PE-Xc				
16 - 32	2,2 – 3,2	elastomeric	8,0 – 9,0	CS
16 - 63	2,2 – 4,5	elastomeric	32,0 - 39	CS
Viega Raxofix – material: PE-Xc/Al/PE-Xc				
16 - 32	2,2 – 3,2	elastomeric	8,0 - 33,0	CS

8.3.2.23.4 Pipes in flexible wall ($t_E \geq 100$ mm), pipe group 1, EI 90, zero distance between CFS-C EL collar and CFS-B, wrapped around PE foamed insulation or PE protection tube on aluminum composite pipes

Situation for EI 90 - U/U:

- Zero distance between CFS-C EL collar and CFS-B, wrapped around PE foamed insulation or PE protection tube on aluminum composite pipes ($s_1 \geq 0$ mm)
- Type of pipes: refer to 8.3.2.1; 8.3.2.2; 8.3.2.3, 8.3.2.4; 8.3.2.5; 8.3.2.8; 8.3.2.9; 8.3.2.10; 8.3.2.12
- Range of pipes: refer to 8.3.2.1; 8.3.2.2; 8.3.2.3, 8.3.2.4; 8.3.2.5; 8.3.2.8; 8.3.2.9; 8.3.2.10; 8.3.2.12

Excluded are only pipes with outside nominal diameter ($d_c \geq 110$ mm).

Pipes in zero distance to CFS-C EL:

- see table of aluminum composite pipes below

PE foamed insulation at aluminum composite pipes:

- As preinstalled by producer or
- Refer to assessed types to 7.1.14

Gap size and gap filling:

Gap filling in flexible wall application ($t_E \geq 100$ mm):

- Gap filler: Hilti CFS-S ACR or gypsum
- Annular Gap: 0 – 15 mm
- Depth t_{A2} to be filled with Hilti CFS-S ACR or gypsum ($t_{A2} \geq 25$ mm)
- No backfilling required

Gap filling in rigid wall application ($t_E \geq 100$ mm):

- Gap filler: Hilti CFS-S ACR
- Annular gap: 0 – 15 mm
- Depth t_{A2} to be filled with Hilti CFS-S ACR ($t_{A2} \geq 25$ mm)
- No backfilling required
- or:
- Gap filler: cementious Mortar M10 acc. EN 998-2
- Annular gap: 0 – 40 mm
- Depth to be filled with cementious Mortar M10: to fill over entire wall thickness
- or:
- Gap filler: Hilti CFS-S ACR
- Annular gap: 0 – 40 mm
- Depth t_{A2} to be filled with Hilti CFS-S ACR ($t_{A2} \geq 25$ mm)
- Back filled with mineral wool, refer to Annex 2, chapter 7.2

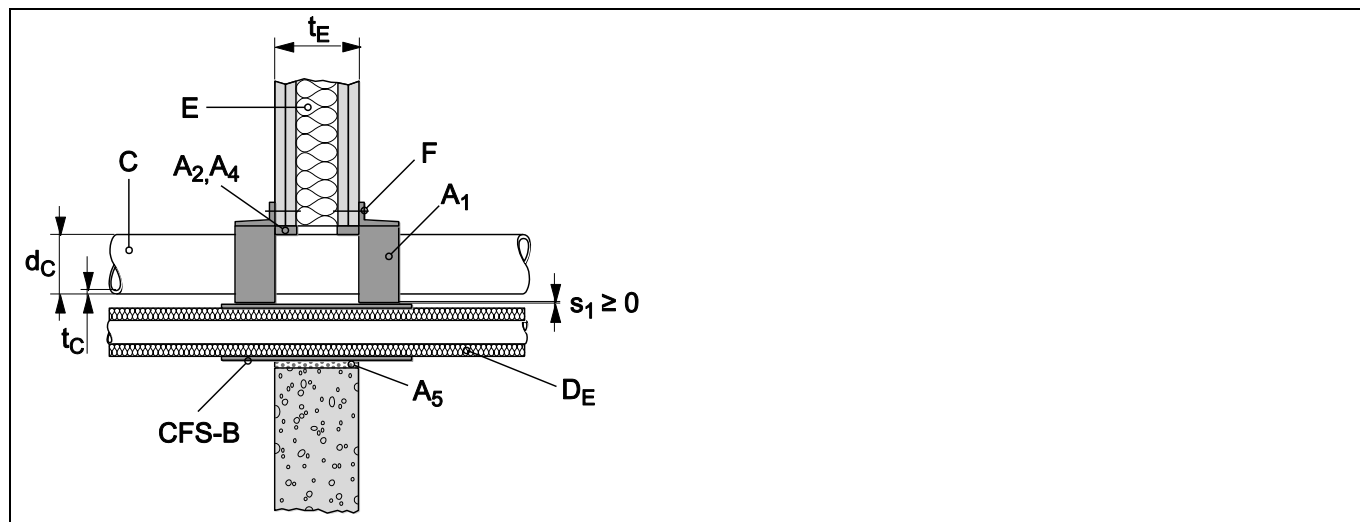

PE foamed insulation or PE protection tube on aluminum composite EI90 U/C

Pipe Ø (mm)	Wall thickness (mm)	Pipe Insulation		
		Type	Thickness (mm)	Configuration (mm)
Geberit Mepla – material: PE-Xb/Al/PE-Xb				
16 - 26	2,2 - 3,0	PE-foam	6,0 – 13,0	CS
Kekelit Kelox – material: PE-RT/Al/PE-RT				
14 - 32	2,0 - 3,0	PE-foam	4,0 – 9,0	CS
16 - 20	2,0 - 2,25	PE-HD tube		LS ≥ 250
16 - 20	2,0 - 2,25	PE Foam + PE-HD tube	4,0	CS
Uponor Unipipe MLC – material: PE-RT/Al/PE-RT				
16 - 20	2,0 - 2,25	PE-HD tube		LS ≥ 250
Uponor Unipipe Plus – material: PE-RT/Al/PE-RT				
16 - 25	2,0 - 2,5	PE foam	4,0 -10,0	CS

8.3.2.24 Pipes in flexible wall ($t_E \geq 100$ mm), pipe group 1, EI 90 – U/U, CFS-C EL collar installed on plastic pipes, sealed by using the coated board CFS-CT B 1S

Situation for EI 90 - U/U (refer to 8.2.14):

- Plastic pipes, penetrating a wall seal made of mineral wool board, could be sealed with CFS-C EL
 - Type of pipes: refer to 8.3.2.1; 8.3.2.2; 8.3.2.4; 8.3.2.5; 8.3.2.8; 8.3.2.9; 8.3.2.10; 8.3.2.12
 - Range of pipes: refer to 8.3.2.1; 8.3.2.2; 8.3.2.4; 8.3.2.5; 8.3.2.8; 8.3.2.9; 8.3.2.10; 8.3.2.12
- Excluded are only pipes with outside nominal diameter ($d_C \geq 110$ mm)
- Distance between the pipes penetrating the board is ($s_1 \geq 80$ mm)
 - Pipes have to be grouped in line only
 - The number of penetrating pipes in line is not limited.
 - Pipes are allowed with zero distance to building element ($s_3 \geq 0$ mm)
 - Gap seal around the board to building element is CFS-S ACR
 - Gap seal around the pipes to board is CFS-S ACR
 - For allowed boards refer to 8.2.14 and Annex 2, Chapter 7.2

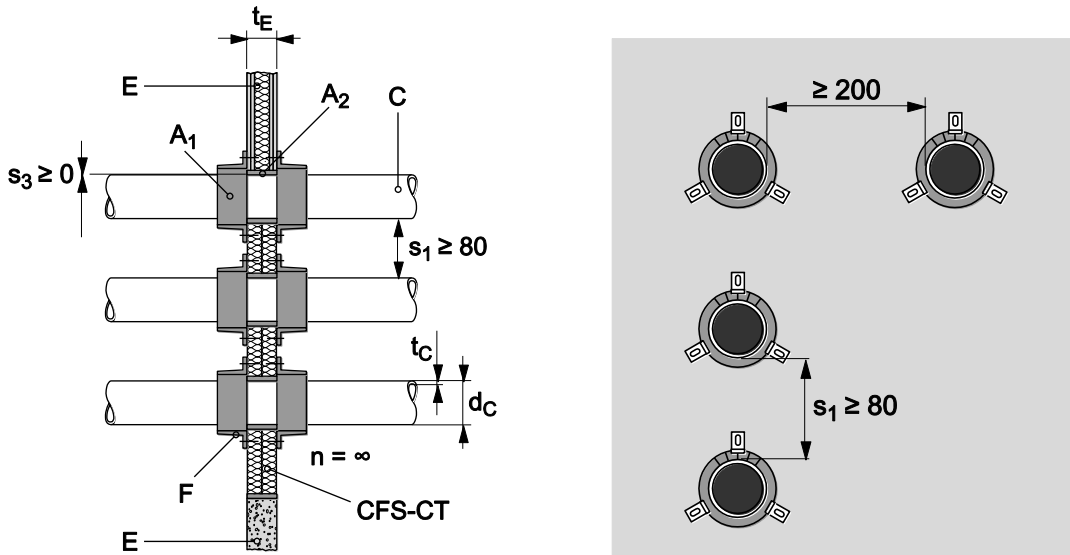

8.3.2.25 Pipes in flexible wall ($t_E \geq 100$ mm), pipe group 1, EI 90 - U/U, CFS-C EL collar to collar (zero distance)

Situation for EI 90 - U/U (refer to 8.2.9):

- Zero distance between two CFS-C EL collars, sealing two plastic pipes ($s_1 \geq 0$ mm)
 - Type of pipes: refer to 8.3.2.1; 8.3.2.2; 8.3.2.4; 8.3.2.5; 8.3.2.8; 8.3.2.9; 8.3.2.10; 8.3.2.12
 - Range of pipes: refer to 8.3.2.1; 8.3.2.2; 8.3.2.4; 8.3.2.5; 8.3.2.8; 8.3.2.9; 8.3.2.10; 8.3.2.12
- Excluded are only pipes with outside nominal diameter ($d_C \geq 110$ mm)
- Pipes have to be group in line
 - Number of pipes in line is unlimited

8.3.2.26 PP pipes acc. EN 1451-1 and DIN 8077/78, in flexible and rigid wall ($t_E \geq 100$ mm), pipe group 1, EI 120 - U/U, Pipe coupling

Situation for EI 120 - U/U:

- Pipe coupling inside the wall, half in the wall or outside the wall, covered by CFS-C EL
- Type of pipes: PP pipes acc. EN 1451-1
- Range of pipes:

Pipe Range:

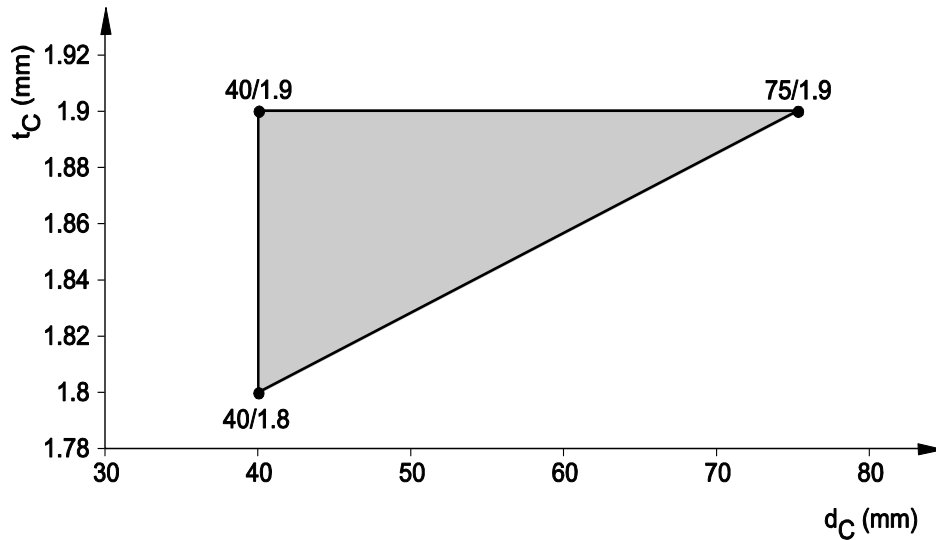

- Pipe sound decoupling: see 8.2.6

Gap size and gap filler:

In flexible wall application ($t_E \geq 100$ mm):

- Gap filler: Hilti CFS-S ACR or gypsum
- Annular gap: 0 – 15 mm
- Depth t_{A2} to be filled with Hilti CFS-S ACR or gypsum ($t_{A2} \geq 25$ mm)
- No backfilling required

In rigid wall application ($t_E \geq 100$ mm):

- Gap filler: Hilti CFS-S ACR
- Annular gap: 0 – 15 mm
- Depth t_{A2} to be filled with Hilti CFS-S ACR ($t_{A2} \geq 25$ mm)
- No backfilling required
- or:
- Gap filler: cementious Mortar M10 acc. EN 998-2
- Annular gap: 0 – 40 mm
- Depth to be filled with cementious Mortar M10: to fill over entire wall thickness
- or:
- Gap filler: Hilti CFS-S ACR
- Annular gap: 0 – 40 mm
- Depth t_{A2} to be filled with Hilti CFS-S ACR ($t_{A2} \geq 25$ mm)
- Back filled with mineral wool, refer to Annex 2, chapter 7.2

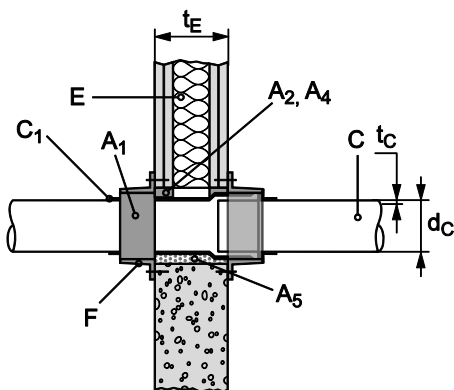

Requested number of hooks:

Pipe outside nominal diameter d_c (mm)	Acoustic Pipe Insulation Thickness t_D (mm)		
	(incoming pipe / outgoing pipe)		
	0	4	9
40	2 / 2	2 / 2	2 / 2
41 - 75	3 / 3	3 / 3	3 / 3

If pipe insulation thickness is between 0 and 4 mm use the number of hooks indicated for 4 mm.
 If pipe insulation thickness is between 4 and 9 mm use the number of hooks indicated for 9 mm.

8.3.2.27 PVC – pipes acc. EN 1452-1, EN 1329-1, EN 1453-1, EN 1566-1, DIN 8061/62, EN ISO 15493, in flexible and rigid wall ($t_E \geq 100$ mm) pipe group 1, EI 120 - U/U, Pipe Elbow 87°

Situation for EI 120 - U/U:

- 87° Elbow, Elbow partly or completely inside the wall, covered by CFS-C EL
- Range of pipes:

Pipe Range:

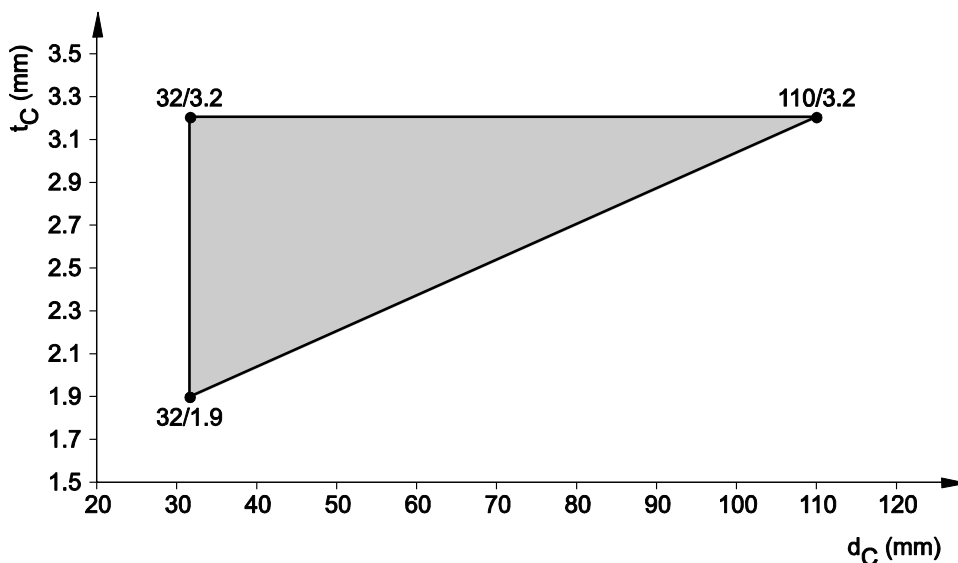

- On one side of the wall pipe runs parallel to wall with zero distance ($s_3 \geq 0$ mm).

Gap size and gap filler:

In flexible and massive wall application ($t_E \geq 100$ mm):

- Gap filler: Hilti CFS-FIL
- Annular gap: 5 – 40 mm
- Depth t_{A2} to be filled with Hilti CFS-FIL ($t_{A2} \geq 25$ mm)
- No backfilling required

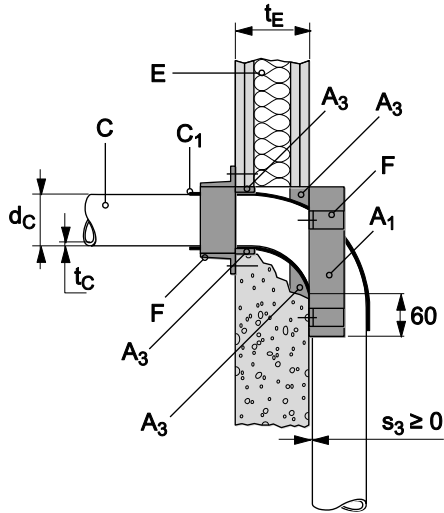

Requested number of hooks:

Pipe outside nominal diameter d_c (mm)	Acoustic Pipe Insulation Thickness t_D (mm) (no elbow side - horizontal running pipe / elbow side - vertical running pipe)		
	0	4	9
32 - 109	3 / 3	3 / 3	3 / 3
110	4 / 4	4 / 4	4 / 4

If pipe insulation thickness is between 0 and 4 mm use the number of hooks indicated for 4 mm.
 If pipe insulation thickness is between 4 and 9 mm use the number of hooks indicated for 9 mm.

8.3.2.28 **PP – pipes acc. EN 1451-1 and DIN 8077/78, in flexible and rigid wall ($t_E \geq 100$ mm) pipe group 1, EI 90 - U/U, Pipe Elbow 87°**

Situation for EI 90 - U/U:

- 87° Elbow Pipes, Elbow partly or completely inside the wall, covered by CFS-C EL
- Range of pipes: see below

Pipe Range:

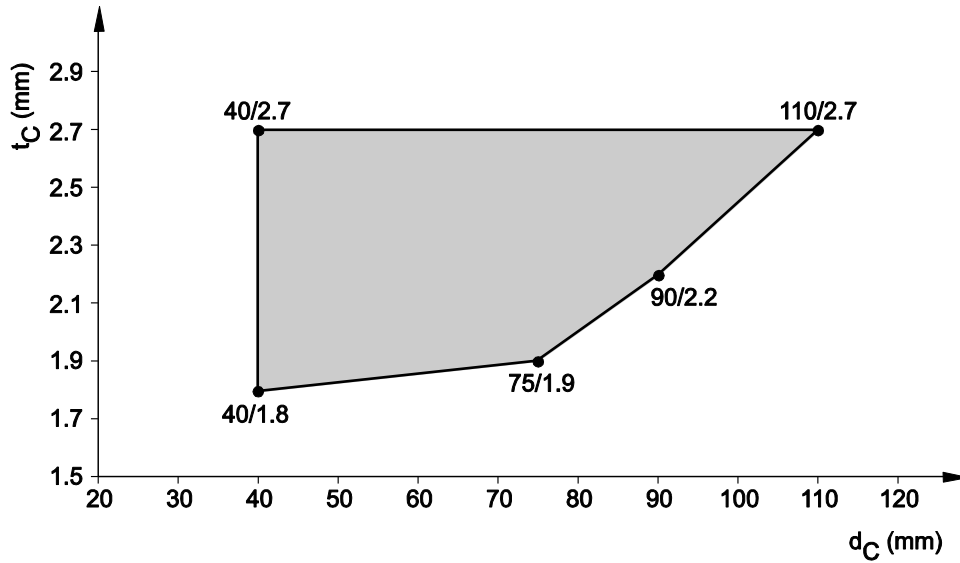

- On one side of the wall pipe runs parallel to wall with zero distance ($s_3 \geq 0$ mm).

Gap size and gap filler:

In flexible wall application ($t_E \geq 100$ mm):

- Gap filler: Hilti CFS-S ACR or gypsum
- Annular gap: 0 – 15 mm
- Depth t_{A2} to be filled with Hilti CFS-S ACR or gypsum ($t_{A2} \geq 25$ mm)
- No backfilling required

In rigid wall application ($t_E \geq 100$ mm):

- Gap filler: Hilti CFS-S ACR
- Annular gap: 0 – 15 mm
- Depth t_{A2} to be filled with Hilti CFS-S ACR ($t_{A2} \geq 25$ mm)
- No backfilling required
- or:
- Gap filler: Hilti CFS-S ACR
- Annular gap: 0 – 40 mm
- Depth t_{A2} to be filled with Hilti CFS-S ACR ($t_{A2} \geq 25$ mm)
- Back filled with mineral wool, refer to Annex 2, chapter 7.2
- or:
- Gap filler: cementious Mortar M10 acc. EN 998-2
- Annular gap: 0 – 40 mm
- Depth to be filled with cementious Mortar M10: to fill over entire wall thickness

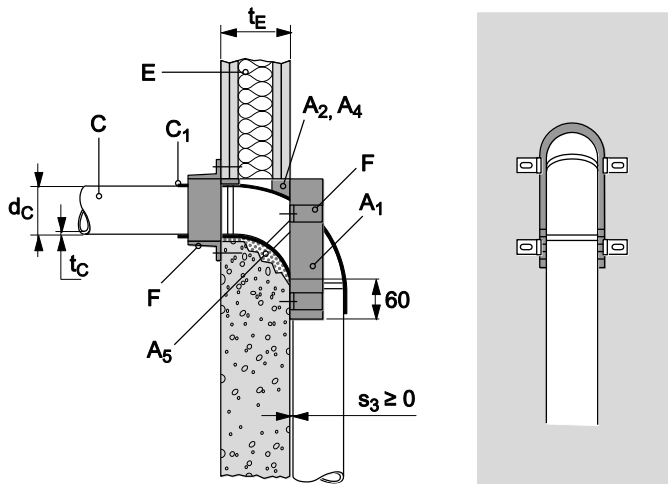

Requested number of hooks:

Pipe outside nominal diameter d_c (mm)	Acoustic Pipe Insulation Thickness t_D (mm)		
	(no elbow side - horizontal running pipe / elbow side - vertical running pipe)		
	0	4	9
40 - 74	3 / 3	3 / 3	3 / 3
75 - 109	3 / 3	3 / 3	3 / 3
110	3 / 4 (on Elbow side)	3 / 4 (on Elbow side)	3 / 4 (on Elbow side)

If pipe insulation thickness is between 0 and 4 mm use the number of hooks indicated for 4 mm.
 If pipe insulation thickness is between 4 and 9 mm use the number of hooks indicated for 9 mm.

8.4 Rigid walls

8.4.1 Specific characteristics for Rigid walls ($t_E \geq 100$ mm)

8.4.1.1 Rigid walls

The wall must have a minimum thickness of ($t_E \geq 100$ mm) and minimum density of ($\rho_E \geq 650$ kg/m³) and comprise concrete, aerated concrete, brickwork, lime malm bricks or masonry.

8.4.1.2 Annular gap filled with

Annular gap around penetrating item has to be filled with:

- Cementious mortar acc. EN 998-2 group M10 over the entire thickness of the wall or
- Hilti Firestop Acrylic Sealant CFS-S ACR (A_2) on both sides with a depth of minimum ($t_{A2} \geq 25$ mm) from the surface of the wall, backfilled with mineral wool or
- Hilti Firestop Acrylic Sealant CFS-S ACR (A_2) only with a depth of ($t_{A2} \geq 25$ mm) from the surface of the wall

Annular gap width should be:

- 0 – 40 mm (when sealed with mortar group M10 acc. EN 998-2 over the entire wall thickness)
- 0 – 40 mm (when sealed with Hilti Firestop Acrylic Sealant CFS-S ACR and mineral wool backfilling)
- 0 – 15 mm (when sealed with Hilti Firestop Acrylic Sealant CFS-S ACR only)

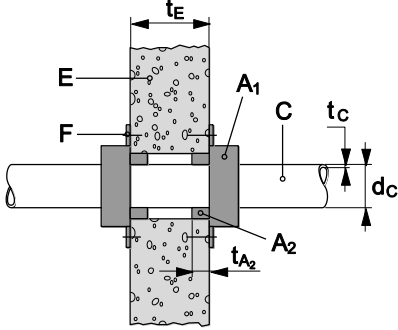
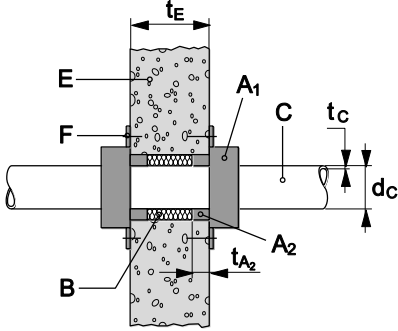
<p>Plastic pipe, penetrating a rigid wall, sealed with Hilti Firestop Collar Endless CFS-C EL. Used gap filler is CFS-S ACR only. Pipes are allowed with and without sound decoupling insulation.</p>	
<p>Plastic pipe, penetrating a rigid wall, sealed with Hilti Firestop Collar Endless CFS-C EL. Used gap filler is CFS-S ACR with mineral wool backing. Pipes are allowed with and without sound decoupling insulation.</p>	

Plastic pipe, penetrating a rigid wall, sealed with Hilti Firestop Collar Endless CFS-C EL. Used gap filler is mortar group M10 acc. EN 998-2 over the entire wall thickness.

Pipes are allowed with and without sound decoupling insulation.

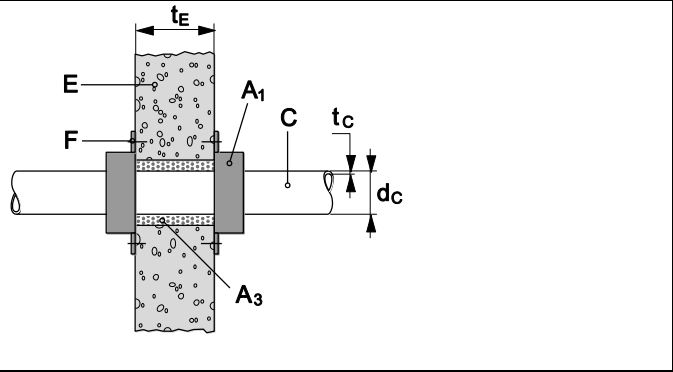

8.4.1.3 Collar fixing

Hilti Firestop Collar Endless CFS-C EL (A_1) to be fixed with hooks (F) on the wall. The required number and type of hooks is shown in 8.2.3, Tab.2. Hooks fixing in rigid walls is described in 8.2.4 and Tab.3.

Bent hooks could be pressed into the wet gap seal, made of cementitious mortar.

8.4.2 Penetration services rigid walls ($t_E \geq 100$ mm)

8.4.2.1 PE pipes acc. EN 1519-1, EN 12666-1, EN 12201-2, ABS-pipes acc. EN 1455-1 and SAN+ PVC pipes acc. EN 1565-1 in rigid wall ($t_E \geq 100$ mm), pipe group 1, EI 120 - U/U

Pipe Range:

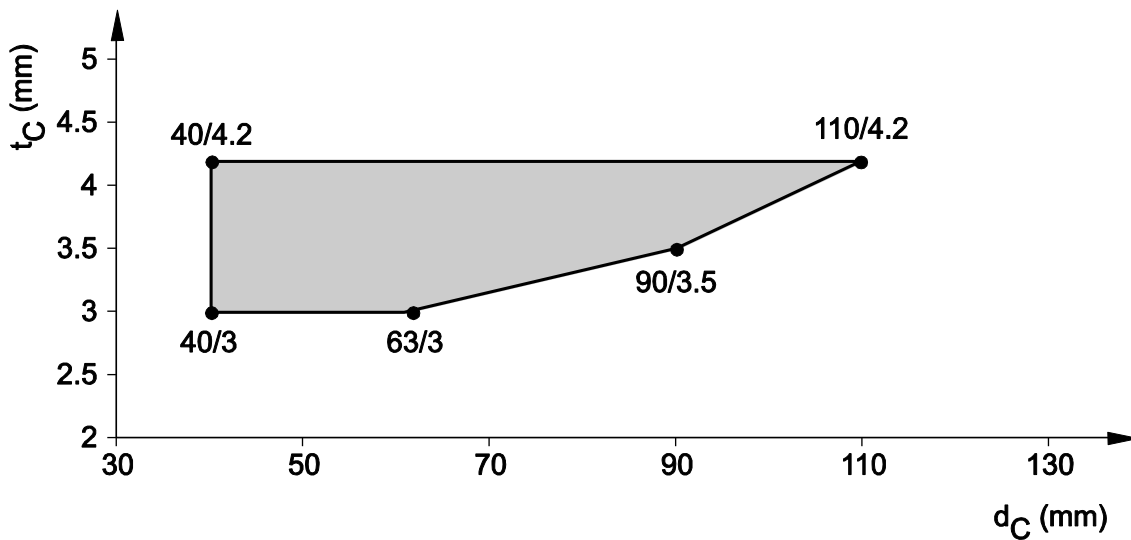

8.4.2.2 PE pipes acc. EN15494, EN 12201-2 and DIN 8074/75, in rigid wall ($t_E \geq 100$ mm), pipe group 1, EI 120, U/U

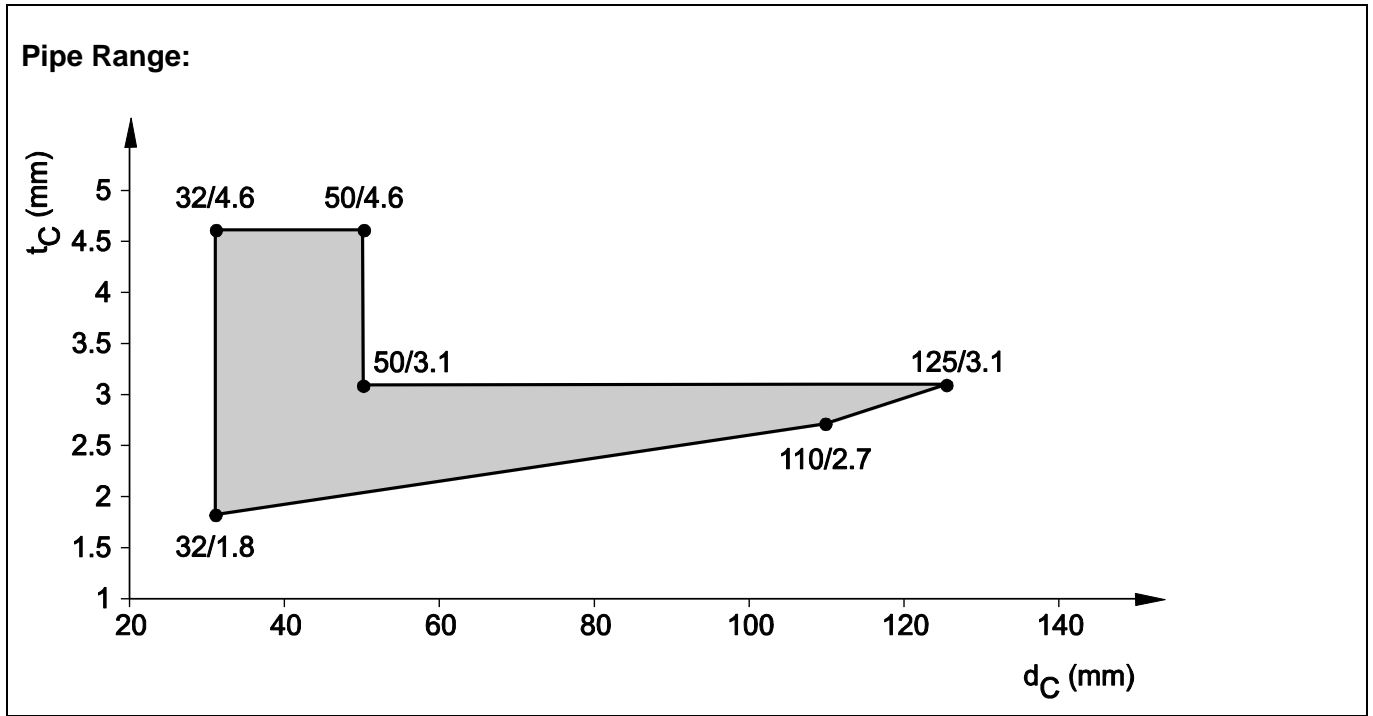

8.4.2.3 PE pipes acc. EN15494, EN 12201-2 and and DIN 8074/75, in rigid wall ($t_E \geq 100$ mm), pipe group 1, EI 120 - U/C

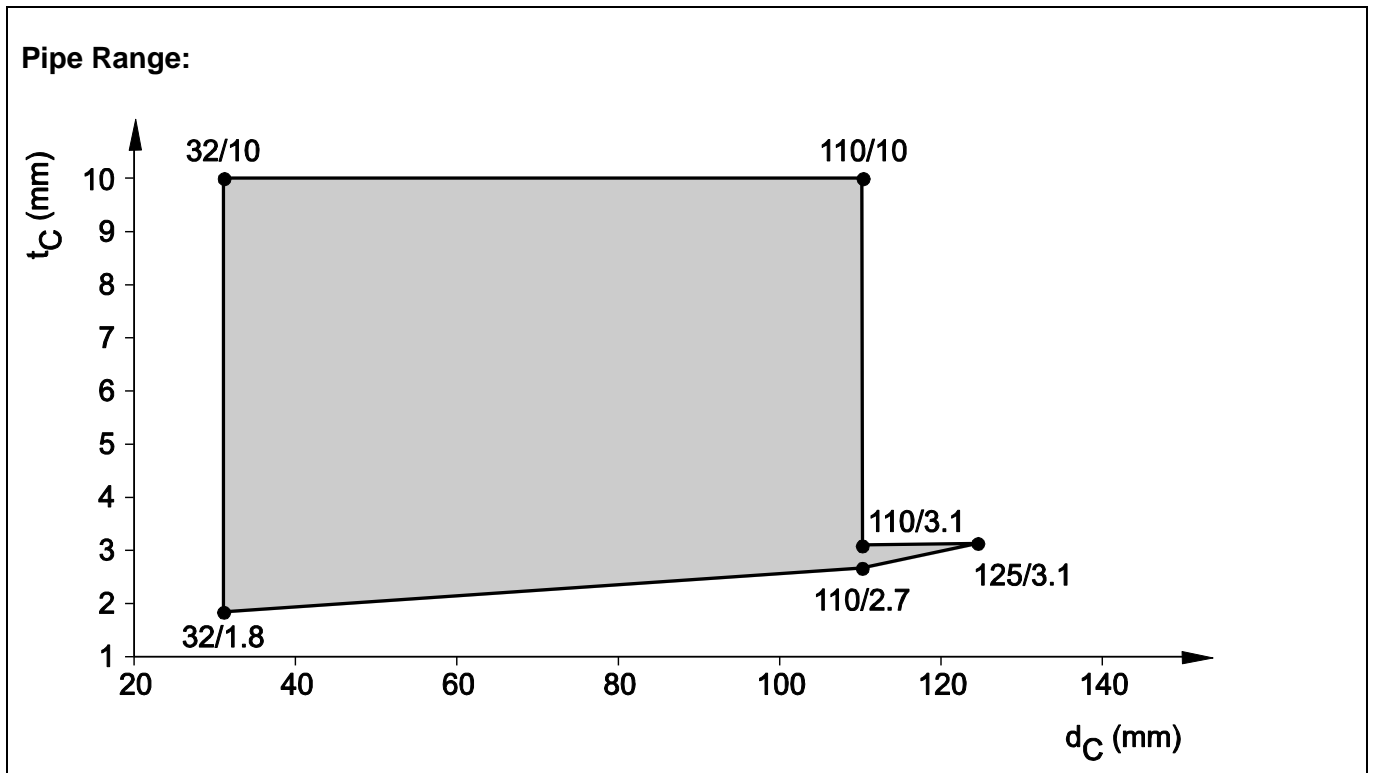

8.4.2.4 PVC pipes acc. EN 1452-1, EN 1329-1, EN 1453-1, EN1566-1, EN ISO 15493 and
 DIN 8061/62 in rigid wall ($t_E \geq 100$ mm), pipe group 1, EI 120 - U/U

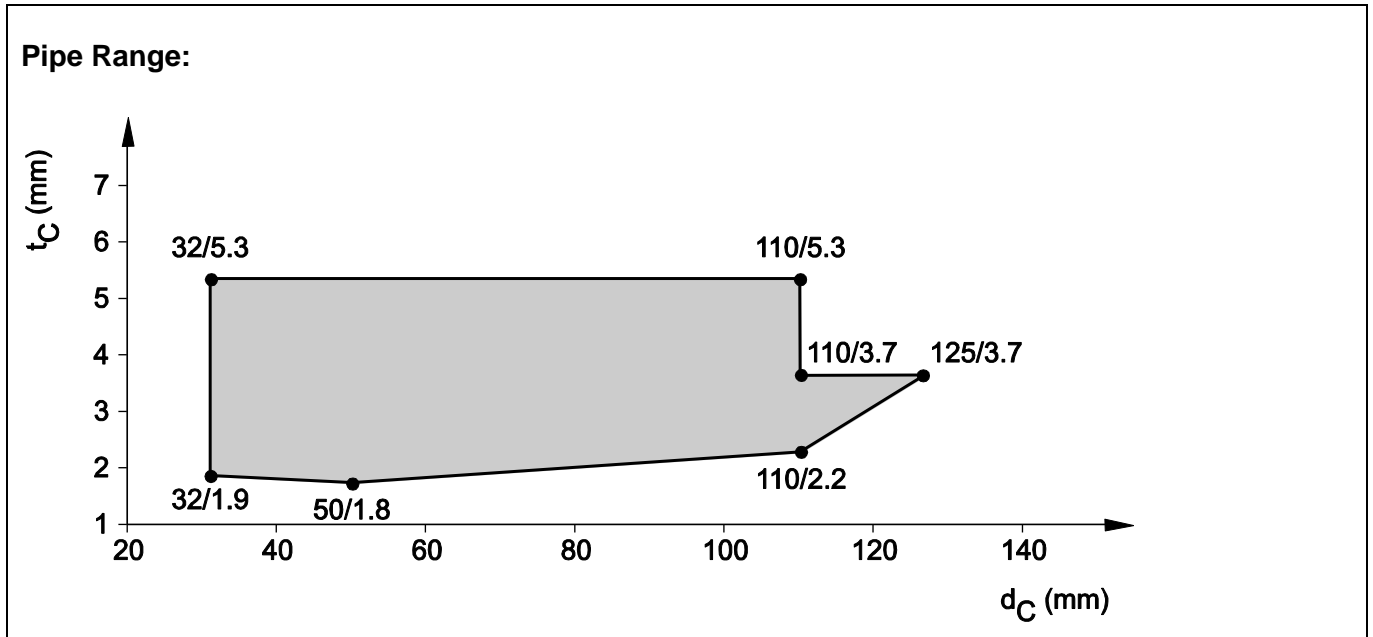

8.4.2.5 PP pipes, non-regulated, in rigid wall ($t_E \geq 100$ mm), pipe group 1, EI 120 - U/U

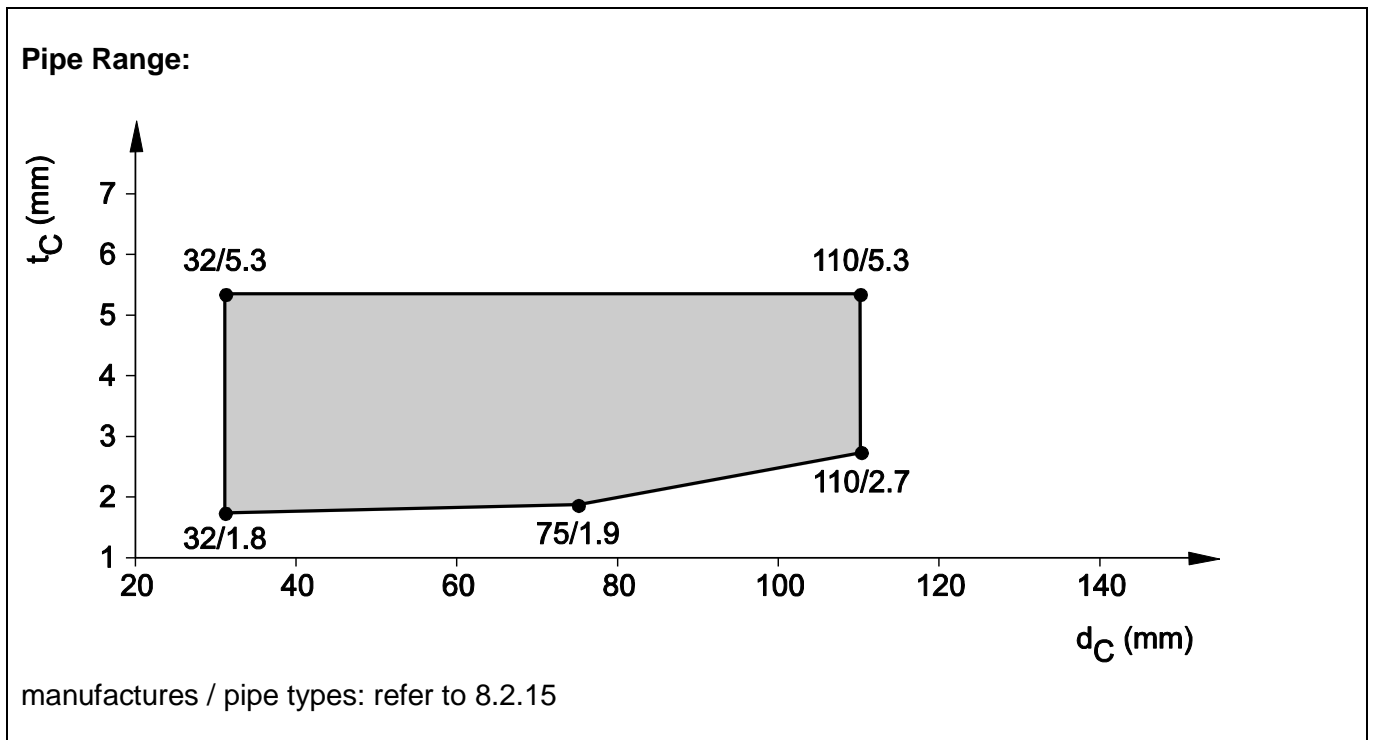

8.4.2.6 PP pipes acc. EN1451-1 and DIN 8077/78, in rigid wall ($t_E \geq 100$ mm), pipe group 1, EI 120 - U/U

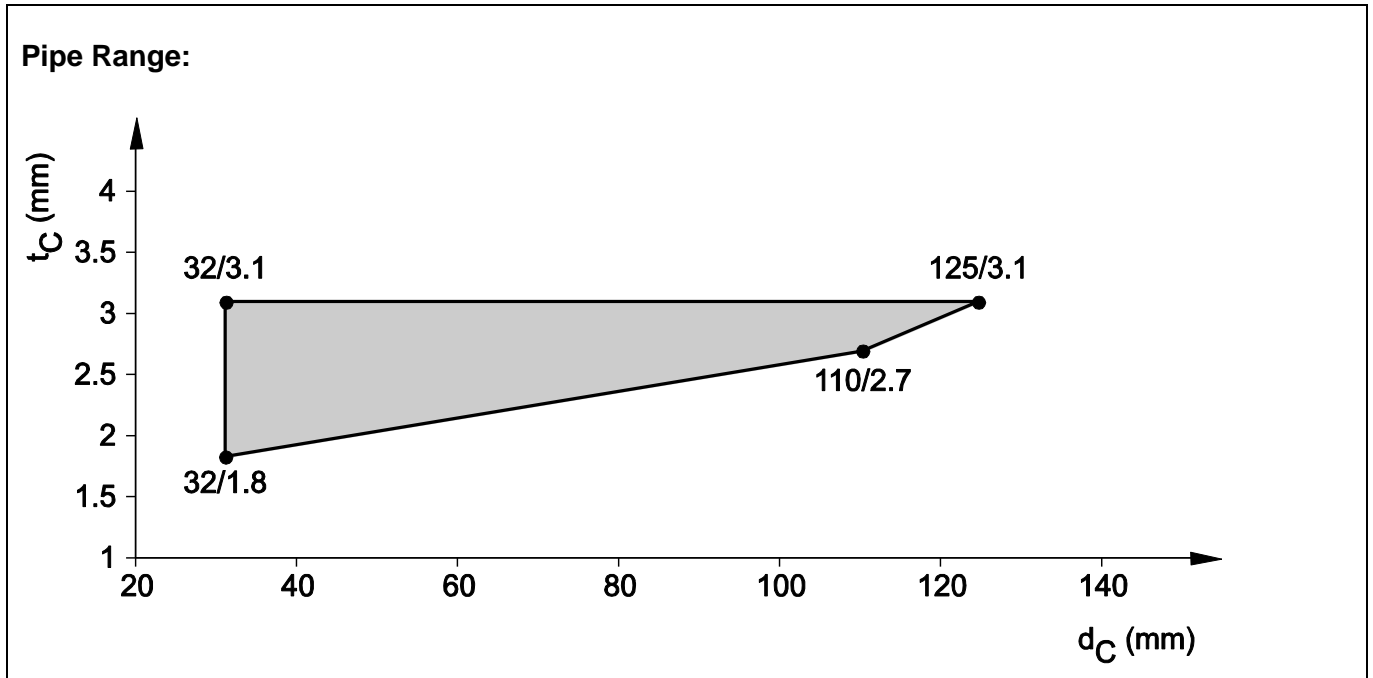

8.4.2.7 PP pipes acc. EN1451-1 and DIN 8077/78, in rigid wall ($t_E \geq 100$ mm), pipe group 1, EI 120 - U/C

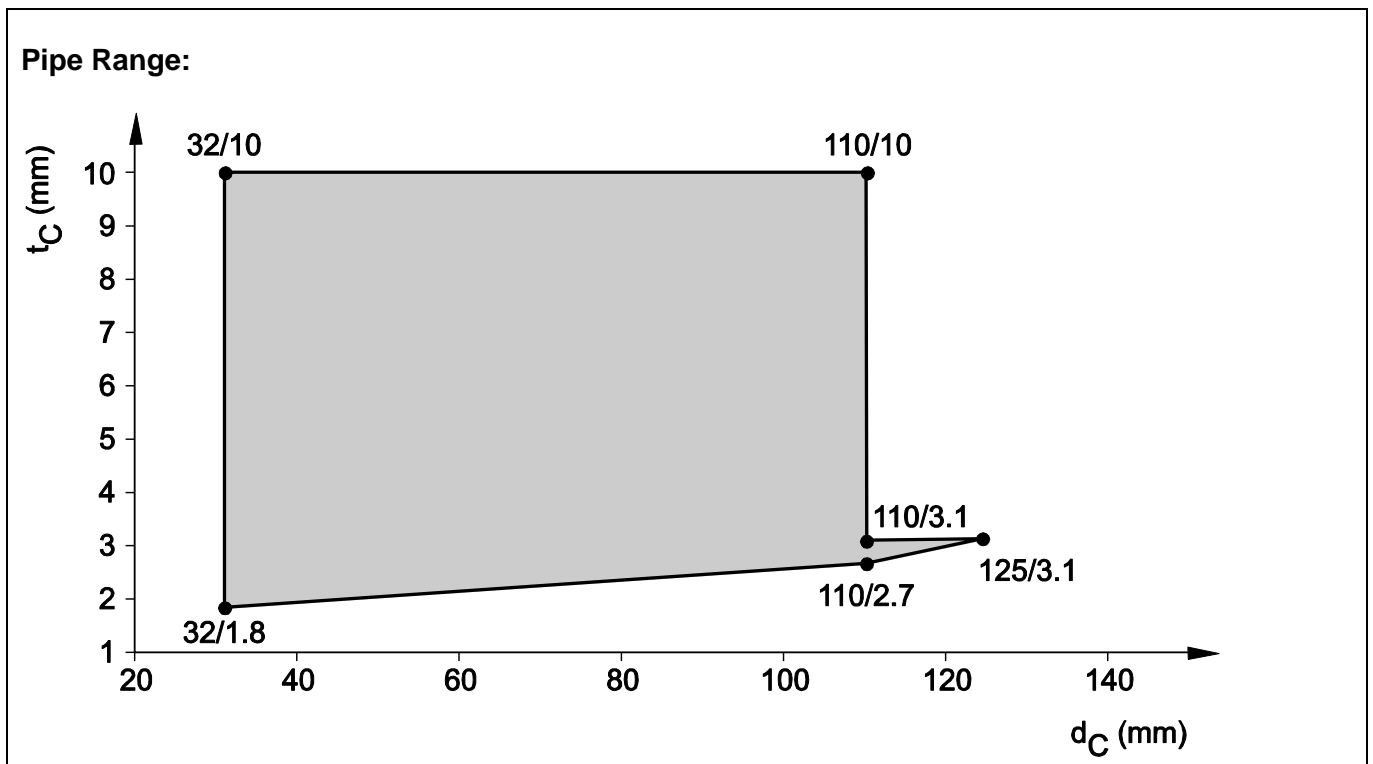

8.4.2.8 Pipes in rigid wall ($t_E \geq 100$ mm), pipe group 1, EI 120 - U/U, pipes directly mounted on the wall - zero distance pipe to wall

All pipes named in 8.4.2.1; 8.4.2.2; 8.4.2.4; 8.4.2.5; 8.4.2.6; 8.4.2.12 may be used in a *Pipe on the wall* application when penetrating a rigid wall thickness ($t_E \geq 100$ mm) with an EI120 - U/U classification.

Excluded are pipes with outside nominal diameter ($d_c \geq 110$ mm).

Only pipes in pipe group 1 (refer to 8.2.2) are tested in this situation.

The pipes run with zero distance directly on wall ($s_3 \geq 0$ mm) before penetrating a wall.

Collar CFS-C EL cannot completely cover the circumference of sealed pipe.

Pictures below show view from above for pipe-on-the-wall application.

For number of hooks refer to 8.2.4 and Tab.3.

For fixing the hooks refer to 8.2.3.

View from above:

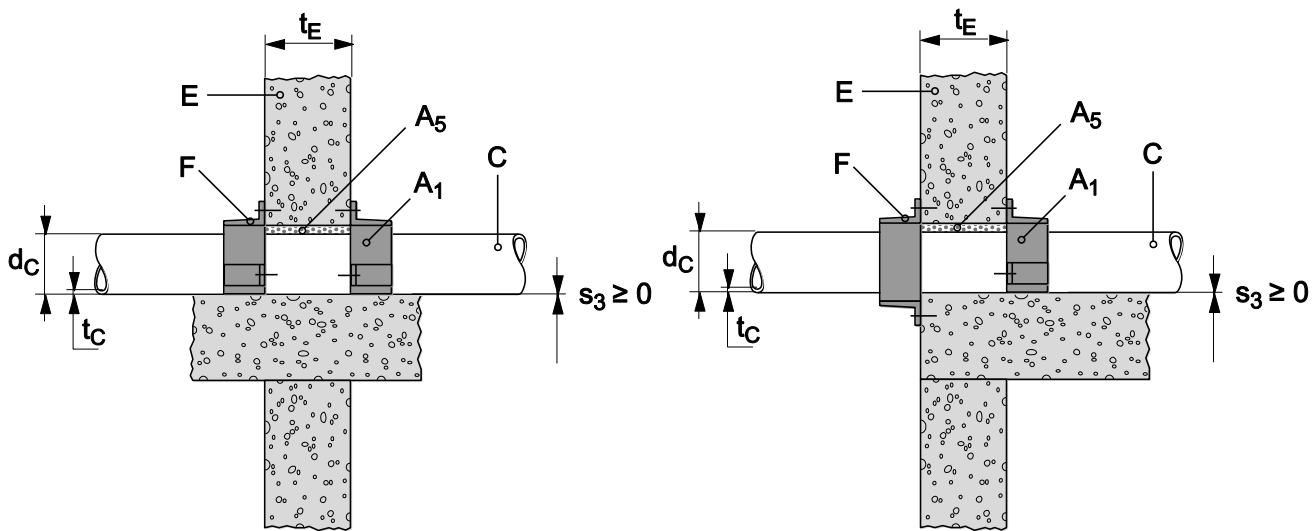

8.4.2.9 **Multiple pipe penetration, covered with foamed elastomeric thermal insulation in rigid wall ($t_E \geq 100$ mm), pipe group 1, EI 120, U/U + U/C**

Situation for multiple pipes for EI 120 classification:

- One PE pipe acc. EN 1519-1, EN 12666-1, EN 12201-2 (U/U) in zero contact ($0 \text{ mm} \leq s_1 \leq 15 \text{ mm}$) together with
- one or two pipes acc. EN 15874 or EN 15875 (pipe material PP-R or PE-X) (U/C)
- The pipes acc. EN 15874 or EN 15875 are insulated with an elastomeric foamed thermal insulation
- Collar CFS-C EL covers the two or three pipes together within one bigger jacket.

PE pipe acc. EN 1519-1, EN 12666-1, EN 12201-2 (U/U):

- Pipe outside diameter is ($40 \text{ mm} \leq d_c \leq 90 \text{ mm}$)
- Pipe wall thickness ($t_c = 3,5 \text{ mm}$)
- With or without sound decoupling isolation (for type, thickness and situation refer to 8.2.6)

PP-R or PE-X pipes acc. EN 15874 and EN 15875 (U/C):

- Pipe outside diameter is ($d_c = 40 \text{ mm}$)
- Pipe wall thickness ($t_c = 5,5 \text{ mm}$)
- Type of pipes: Aquatherm fusiolen (aquatherm green pipe S) and Rehau Rautitan flex

Elastomeric foamed thermal insulation:

- For material type refer to 8.2.12
- Insulation thickness ($9 \text{ mm} \leq t_D \leq 32 \text{ mm}$)
- Installation situation is LS and CS
- Minimum insulation length ($L_D \geq 250 \text{ mm}$) on both sides of the wall

Collar fixing:

- For number of hooks refer to 8.2.4 and Tab.3, for fixing the hooks refer to 8.2.3.

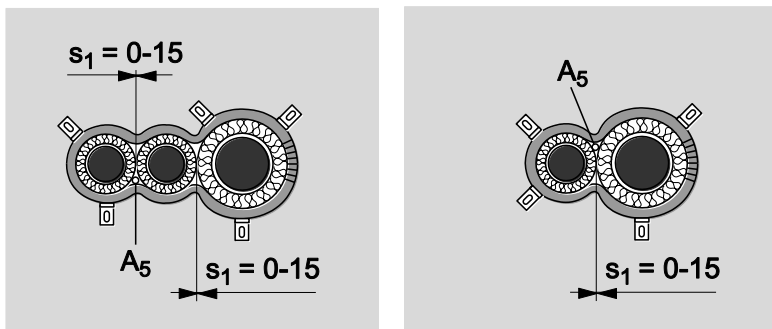

8.4.2.10 Multiple pipe penetration, covered with foamed elastomeric thermal insulation, in rigid wall ($t_E \geq 100$ mm), pipe group 1, EI 120 - U/C, zero distance to floor basement

Situation for multiple pipes for EI 120 – U/C classification:

- One pipe or two pipes are mounted directly on the floor ($s_3 \geq 0$ mm)
- Pipes are located side by side ($s_1 \geq 0$ mm)
- Collar CFS-C EL cannot cover both pipes completely

Pipes:

- PP-R or PE-X pipes acc. EN 15874 and EN 15875 (U/C):
- Type of pipes: Aquatherm fusiolen (aquatherm green pipe S) and Rehau Rautitan flex
- Pipe outside diameter is ($d_C = 40$ mm)
- Pipe wall thickness ($t_C = 5,5$ mm)

Elastomeric foamed thermal insulation:

- For material type refer to 8.2.12
- Insulation thickness is ($t_D = 25$ mm)
- Installation situation is LS and CS
- Minimum insulation length ($L_D \geq 250$ mm) on both sides of the wall

Collar fixing:

- For number of hooks refer to 8.2.4 and Tab.3, for fixing the hooks refer to 8.2.3.

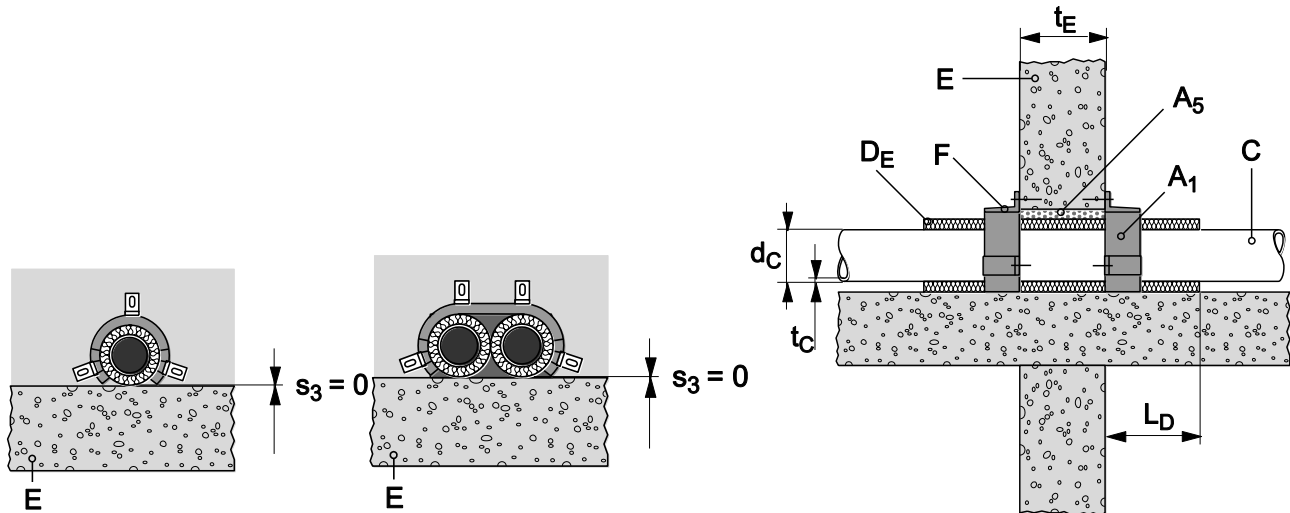

**8.4.2.11 Roof drainage, covered with foamed elastomeric thermal insulation, in rigid wall
($t_E \geq 100$ mm), pipe group 1, EI 90 or EI 120 - U/U**

Situation for roof drainage for EI90 or EI120 – U/U:

- One PE/PP-pipe (U/U) insulated with elastomeric foamed insulation, sealed with CFS-C EL
- Pipe penetrates the wall in perpendicular and inclined (45°) situation
- Any pipe inclination in between 45° and 90°

Pipe:

- Material see table below
- Pipe outside diameter see table below
- Pipe wall thickness see table below

Elastomeric foamed thermal insulation:

- For material type refer to 8.2.12
- Insulation thickness see table below
- Installation situation is LS and CS
- Minimum insulation length ($L_D \geq 250$ mm) on both sides of the wall

Gap size and Gap filler:

- Gap size is 5 mm to 40 mm
- Gap filler is CFS-FIL
- Installation depth: ($t_{A3} \geq 25$ mm) on each side of the wall

Collar fixing in pipe group 1 and 2:

- For perpendicular situation (90°): refer to 8.2.4 and Tab.3, for hook fixing refer to 8.2.3 and Tab.2

Rigid walls ($t_E \geq 100$ mm)			
Pipe material	PE	PE	PP
Norm/standard/ Producer/product	EN 1519-1, EN12666-1, EN 12201-2	Non-regulated, Geberit Silent dB20	Non-regulated, See 8.2.15
Pipe diameter d_C	($40 \leq d_C \leq 110$ mm)	($40 \leq d_C \leq 110$ mm)	-
Pipe wall thickness t_C	($t_C = 4,2$ mm)	($t_C = 6,0$ mm)	-
insulation thickness t_D	($t_D = 19$ mm)	($t_D = 19$ mm)	-
Classification	EI 120	EI 120	-
Rigid walls ($t_E \geq 150$ mm)			
Pipe material	PE	PE	PP
Norm/standard/ Producer/product	EN 1519-1, EN12666-1, EN 12201-2	Non-regulated, Geberit Silent dB20	Non-regulated, See 8.2.15
Pipe diameter d_C	See graphic 8.4.2.11 A and range given above for Rigid walls ($t_E \geq 100$ mm)	See graphic 8.4.2.11 B and range given above for Rigid walls ($t_E \geq 100$ mm)	See graphic 8.4.2.11 C and 8.4.2.11 D
Pipe wall thickness t_C			
insulation thickness t_D	($t_D = 19$ mm)	($t_D = 19$ mm)	($t_D = 19$ mm)
Classification	EI 90	EI 120	EI 90

Gap size and Gap filler:

- Gap size is 5 mm to 40 mm
- Gap filler is CFS-FIL
- Installation depth: ($t_{A3} \geq 25$ mm) on each side of the wall

Collar fixing in pipe group 1 and 2:

- For perpendicular situation (90°): refer to 8.2.4 and Tab.3, for hook fixing refer to 8.2.3 and Tab.2

Pipe Range 8.4.2.11 A:

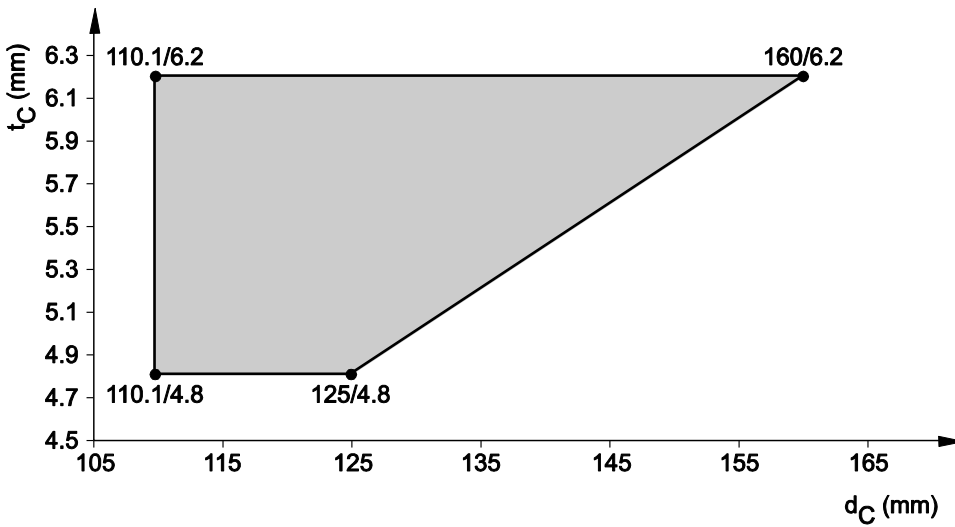

Pipe Range 8.4.2.11 B:

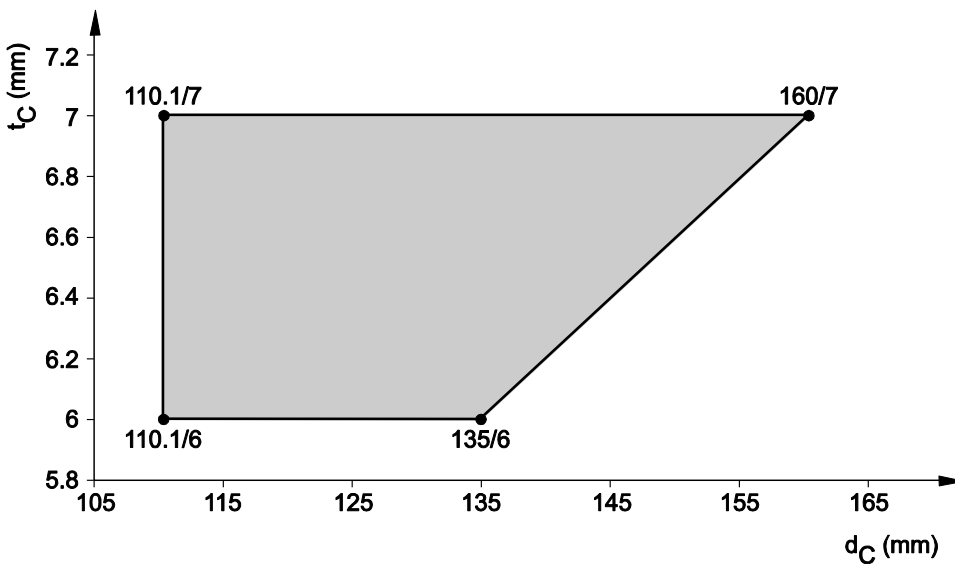

Pipe Range 8.4.2.11 C:

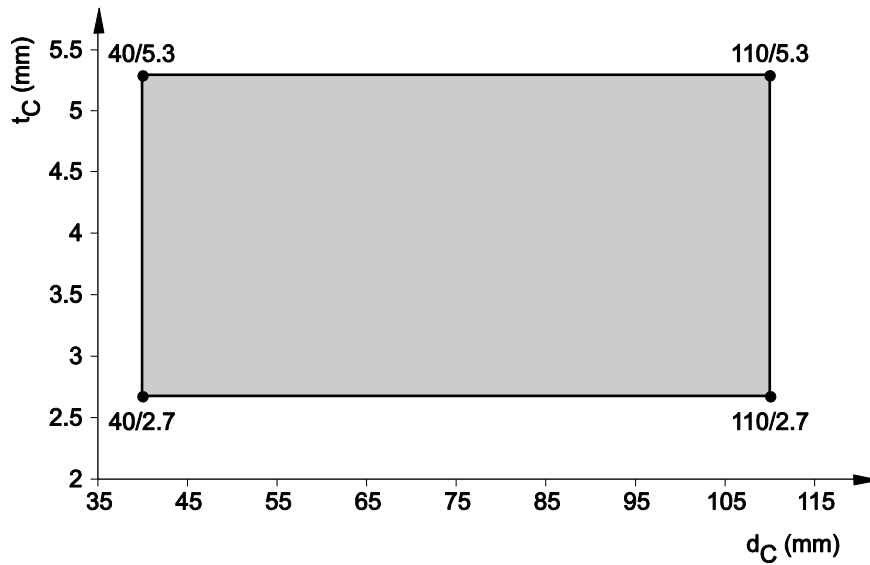

Pipe Range 8.4.2.11 D:

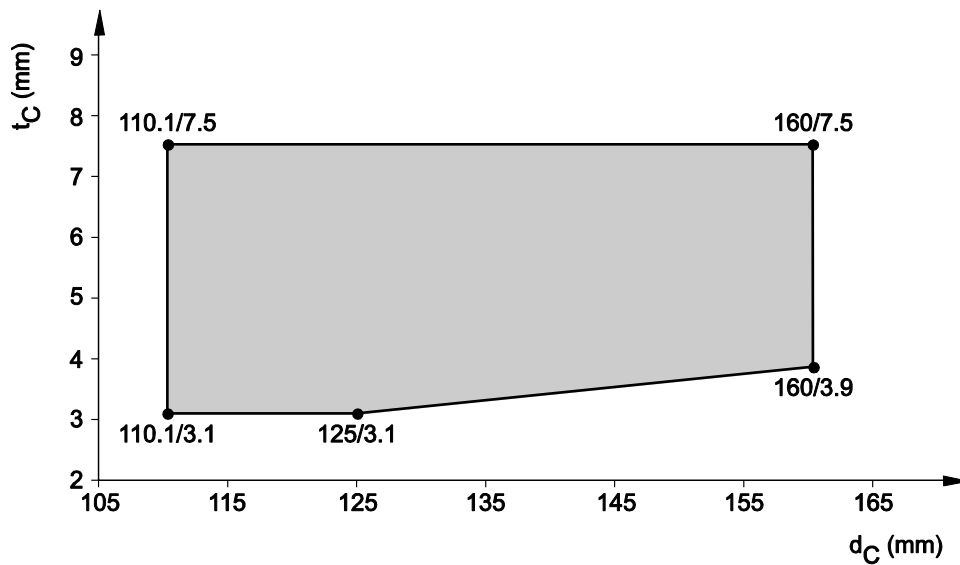

8.4.2.12 **PE pipes, non-regulated (Geberit Silent dB20), in rigid wall ($t_E \geq 100$ mm), pipe group 1, EI 120 – U/U, specific application: 2 x 45° elbow connector**

Situation for EI 120 – U/U:

- Pipe elbow connector (2 pieces, 45° each), within or partly within the wall, covered by Collar CFS-C EL
- On one side of the wall pipe runs parallel to wall ($s_3 \geq 0$ mm)

Pipe:

- Material PE, type of pipe: Geberit Silent dB20
- Elbow connector 45°: Geberit Silent dB20 based on PE, electro-welding wire inside
- Pipe outside diameter is ($d_C = 110$ mm)
- Pipe wall thickness ($t_C = 6$ mm)

Gap size and Gap filler for elbow connector 2 x 45° only:

- Gap size is 5 mm to 40 mm
- Gap filler is CFS-FIL
- Installation depth: $t_{A3} \geq 25$ mm on each side of the wall
- Backfilling with mineral wool, refer to Annex 2, chapter 7.2

Collar fixing:

- For number of hooks refer to 8.4.2.17

8.4.2.13 **PE pipes, non-regulated (Geberit Silent dB20), in rigid wall ($t_E \geq 100$ mm), pipe group 1, EI 30 - U/U, pipe coupling**

Situation for EI 30 – U/U:

- pipe coupling within or partly within the wall, covered by Collar CFS-C EL

Pipe:

- Material PE, type of pipe: Geberit Silent dB20
- Pipe coupling device: Geberit Silent dB20 based on PE, electro-welding wire inside
- Pipe outside diameter is ($d_C = 110$ mm)
- Pipe wall thickness ($t_C = 6$ mm)

Gap size and Gap filler for pipe coupling:

With CFS-S ACR:

- Gap size is 0 mm to 15 mm
- Gap filler is CFS-S ACR
- Installation depth: ($t_{A2} \geq 25$ mm) on each side of the wall
- No backfilling
or:
- Gap size is 0 mm to 40 mm
- Gap filler is CFS-S ACR
- Installation depth: ($t_{A2} \geq 25$ mm) on each side of the wall
- Backfilling with mineral wool, refer to Annex 2, chapter 7.2

With cementious mortar:

- Gap size is (0 mm to 40 mm), Installation depth: over the entire thickness
- Gap filler is mortar group M10 acc. EN 998-2

Collar fixing:

- For number of hooks for pipe coupling: refer to 8.4.2.18

8.4.2.14 Reuse of oddments of CFS-C EL, in rigid wall ($t_E \geq 100$ mm)

Situation:

- Reuse of oddments EI 120 - U/U for pipe group 1
- Reuse of oddments EI 90 - U/U for pipe group 2

Pipe range:

- For pipe group 1 – refer to 8.4.2.1; 8.4.2.2; 8.4.2.4; 8.4.2.5; 8.4.2.6; 8.4.2.12
- For pipe group 2 - refer to 8.4.2.20; 8.4.2.23; 8.4.2.24; 8.4.2.25; 8.4.2.26; 8.4.2.30

Installation details:

- For installation details – refer to 8.2.7

Number of hooks:

- For number of hooks – refer to 8.2.4 and 8.2.7

8.4.2.15 Hooks for CFS-C EL, fixed in rigid wall ($t_E \geq 100$ mm) with wet mortar

Situation:

- Hooks in wet mortar in pipe group 1: EI 120 - U/U
- Hooks in wet mortar in pipe group 2: EI 120 - U/U

Pipe range:

- For pipe group 1 – refer to 8.4.2.1; 8.4.2.2; 8.4.2.4; 8.4.2.5; 8.4.2.6; 8.4.2.12
- For pipe group 2 - refer to 8.4.2.20; 8.4.2.23; 8.4.2.24; 8.4.2.25; 8.4.2.26; 8.4.2.30

Installation details:

- For installation details– refer to 8.2.3

number of hooks:

- For number of hooks – refer to 8.2.4 and Tab.3

8.4.2.16 PE pipes according EN 12201 (Wavin W) sealed with CFS-C EL, in rigid wall ($t_E \leq 100$ mm), pipe group 1, EI 120 - U/C

Situation:

- Isolated PE pipes acc. EN 12201 for EI 120 - U/U

Pipe Range:

- Refer to graphic below
- Material type: PE acc. EN 12201 – Wavin W

Elastomeric foamed thermal insulation:

- For material type refer to 8.2.12
- Insulation thickness is ($t_D = 9$ mm)
- Installation situation is LS and CS
- Minimum insulation length ($L_D \geq 250$ mm) on both sides of the wall

Pipe Range:

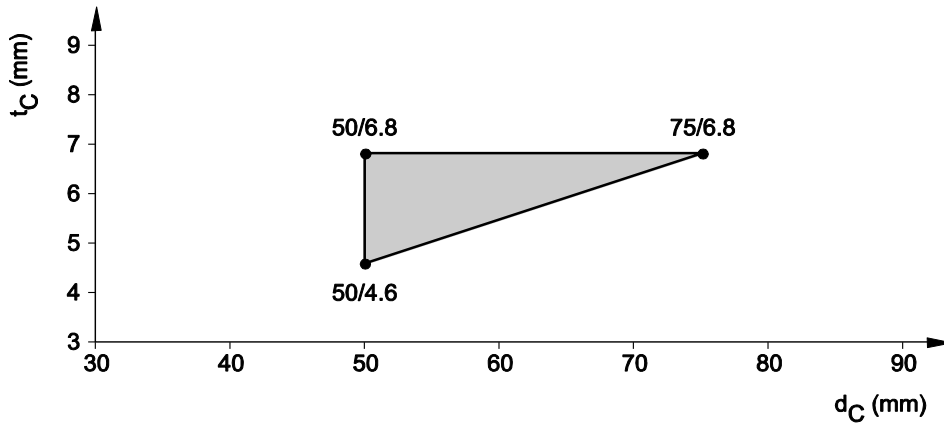

8.4.2.17 PP pipes, non-regulated, gap sealed with CFS-FIL, in rigid wall ($t_E \geq 100$ mm), pipe group 1, EI 90 - U/U, elbow pipe 87°

Situation:

- Elbow connector (87°) for non-regulated PP pipes, installed inside the wall or partly inside the wall, sealed with Collar CFS-C EL for EI 90 – U/U classification
- On one side the pipe may run parallel to the wall having a zero distance to wall ($s_3 \geq 0$ mm)

Pipe range:

- For pipe group 1 – refer to 8.4.2.5
- For pipe material – refer to 8.2.15

Gap size and Gap filler:

- Gap size is 5 mm to 40 mm
- Gap filler is CFS-FIL
- Installation depth: $t_{A3} \geq 25$ mm on each side of the wall
- Backfilling with mineral wool, refer to Annex 2, chapter 7.2

Collar fixing / number of hooks:

Pipe outside nominal diameter d_c (mm)	Acoustic Pipe Insulation Thickness t_D (mm) (no elbow side - vertical running pipe / elbow side - horizontal running pipe)		
	0	4	9
32	2 / 2	2 / 2	2 / 2
50	2 / 2	2 / 2	2 / 3
75	3 / 3	3 / 3	3 / 3
90	3 / 3	3 / 3	3 / 3
110	3 / 4	3 / 4	3 / 4

If pipe insulation thickness is between 0 and 4 mm use the number of hooks indicated for 4 mm.
 If pipe insulation thickness is between 4 and 9 mm use the number of hooks indicated for 9 mm.

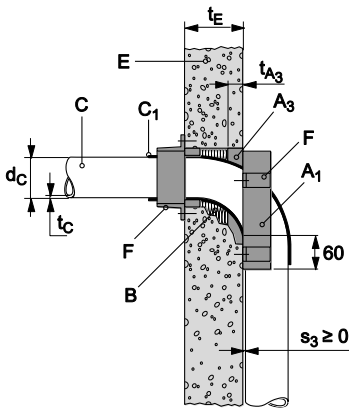

8.4.2.18 PP pipes, non-regulated, gap sealed with CFS-FIL, in rigid wall ($t_E \geq 100$ mm), pipe group 1, EI 120 - U/U, elbow pipe 2 x 45°

Situation:

- Elbow connector (2 x 45°) for non-regulated PP pipes installed inside the wall or partly inside the wall, sealed with Collar CFS-C EL for EI120 – U/U classification
- On one side the pipe may run parallel to the wall having a zero distance to wall ($s_3 \geq 0$ mm).

Pipe range:

- For pipe group 1 – refer to 8.4.2.5
- For pipe material – refer to 8.2.15

Gap size and Gap filler:

- Gap size is 5 mm to 40 mm
- Gap filler is CFS-FIL
- Installation depth $t_{A3} \geq 25$ mm on each side of the wall
- Backfilling with mineral wool, refer to Annex 2, chapter 7.2

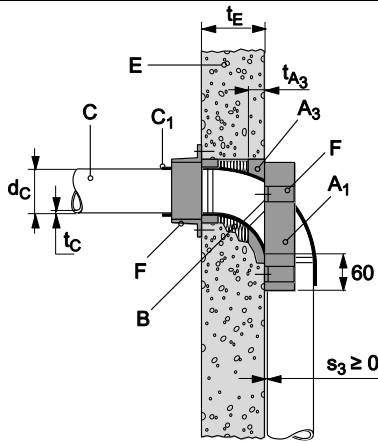

Collar fixing / number of hooks:

Pipe outside nominal diameter d_C (mm)	Acoustic Pipe Insulation Thickness t_D (mm)		
	(no elbow side - horizontal running pipe / elbow side - vertical running pipe)		
	0	4	9
32	2 / 2	2 / 2	2 / 2
50	2 / 2	2 / 2	2 / 3
75	3 / 3	3 / 3	3 / 3
90	3 / 3	3 / 3	3 / 3
110	3 / 4	3 / 4	3 / 4

If pipe insulation thickness is between 0 and 4 mm use the number of hooks indicated for 4 mm.
 If pipe insulation thickness is between 4 and 9 mm use the number of hooks indicated for 9 mm.

8.4.2.19 Pipes in rigid wall ($t_E \geq 100$ mm), pipe group 1, EI 120 - U/U, pipes directly mounted in the corner - zero distance pipe to one wall and one floor

Situation:

- Pipes directly mounted in the corner, sealed with Collar CFS-C EL for EI120 – U/U classification
- Zero distance ($s_3 \geq 0$ mm) pipe to one wall and one floor at same time
- Collar CFS-C EL covers completely the circumference of sealed pipe
- Some building material from affected building elements (from wall and floor) have to be removed to give free access for the collar

Pipe range:

- For pipe group 1 only
 - For pipe material – refer to 8.4.2.1; 8.4.2.2; 8.4.2.4; 8.4.2.5; 8.4.2.6; 8.4.2.12
 - For pipe dimension - refer to 8.4.2.1; 8.4.2.2; 8.4.2.4; 8.4.2.5; 8.4.2.6; 8.4.2.12
- Excluded are pipes with outside nominal diameter ($d_C \geq 110$ mm)

Gap size and Gap filler:

With CFS-S ACR:

- Gap size is 0 mm to 15 mm
 - Gap filler is CFS-S ACR
 - Installation depth: ($10 \text{ mm} \leq t_{A3} \leq 20 \text{ mm}$) on each side of the wall
 - No backfilling
- or:
- Gap size is 0 mm to 40 mm
 - Gap filler is CFS-S ACR
 - Installation depth: ($t_{A3} \geq 25 \text{ mm}$) on each side of the wall
 - Backfilling with mineral wool, refer to Annex 2, chapter 7.2

With cementious mortar:

- Gap size is (0 mm to 40 mm)
- Gap filler is mortar group M10 acc. EN 998-2
- Installation depth: over the entire thickness of the wall

Number of hooks:

- For number of hooks – refer to 3.1.4

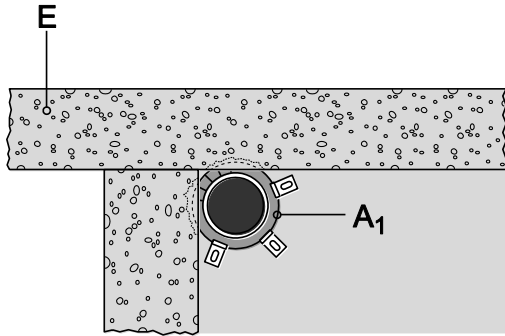

**8.4.2.20 PE pipes acc. EN 1519-1, EN 12201-2 and EN 12666-1, in rigid wall ($t_E \geq 150$ mm),
pipe group 2, EI 120 - U/U**

Pipe Range:

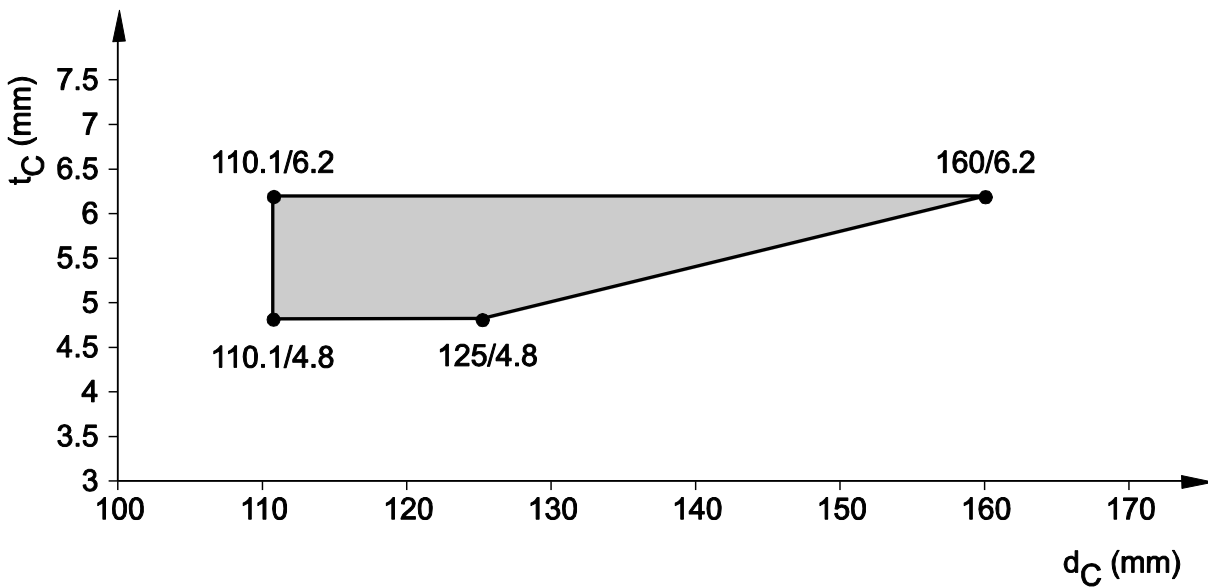

8.4.2.21 **ABS pipes acc. EN 1455-1, EN 15493 and SAN+PVC-pipes acc. EN 1565-1, in rigid wall ($t_E \geq 150$ mm), pipe group 2, EI 90 - U/U**

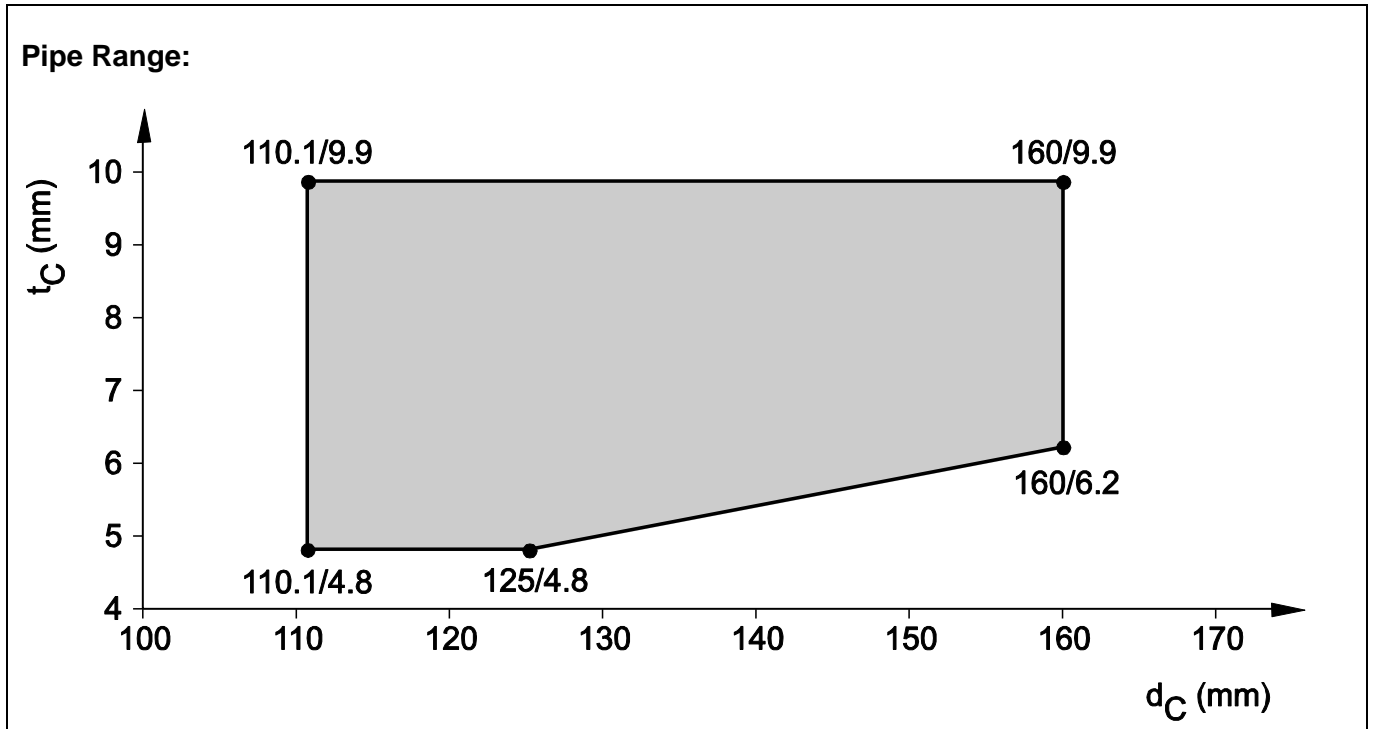

8.4.2.22 **ABS pipes acc. EN 1455-1, EN 15493 and SAN+PVC-pipes acc. EN 1565-1, in rigid wall ($t_E \geq 150$ mm), pipe group 2, EI 120 - U/C**

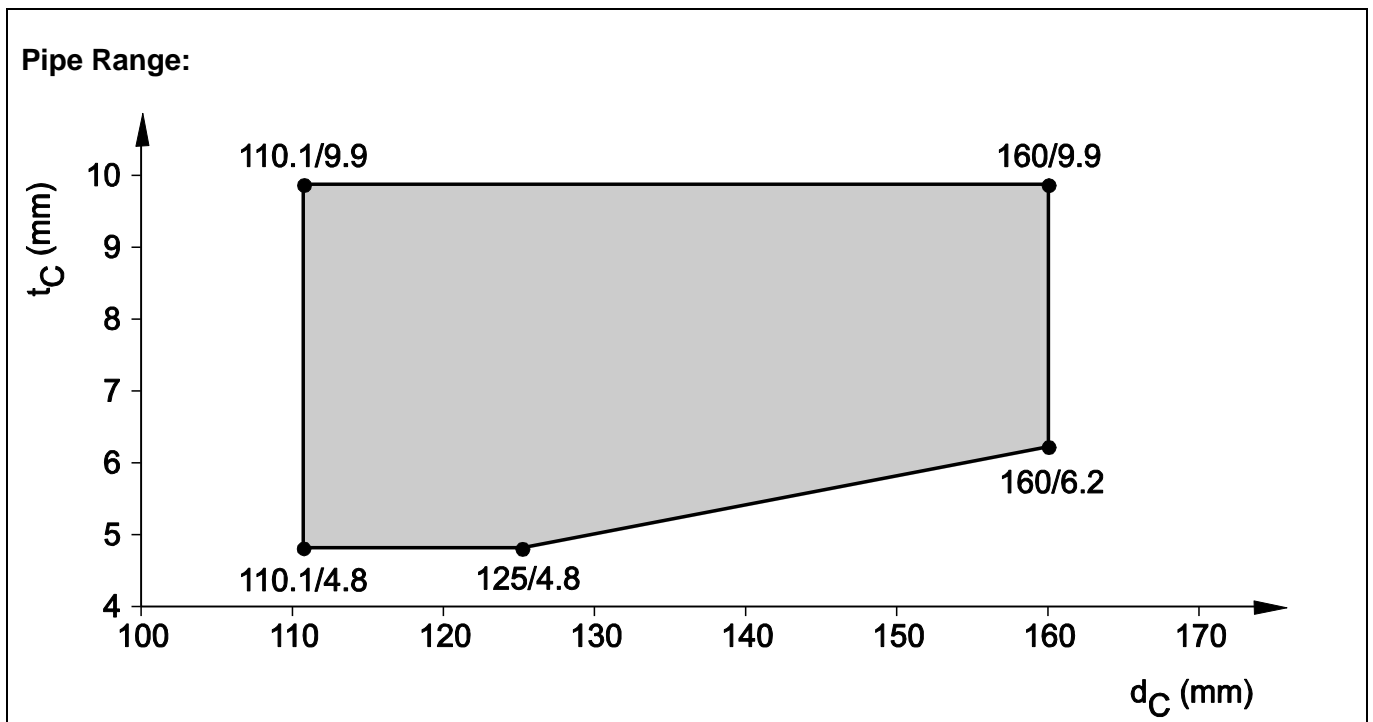

8.4.2.23 PE pipes acc. EN 15494, EN 12201-2 and DIN 8074/75, in rigid wall ($t_E \geq 150$ mm),
pipe group 2, EI 120 - U/U

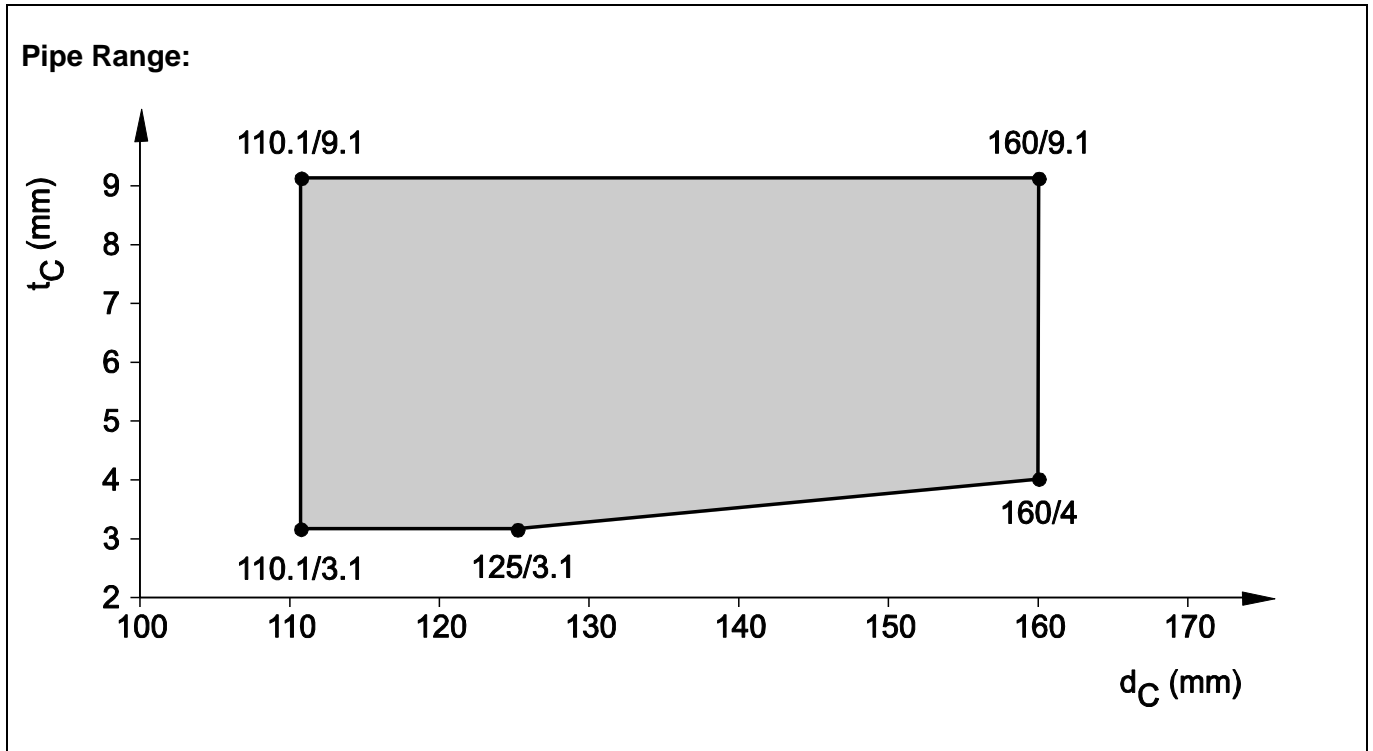

8.4.2.24 PVC pipes acc. EN 1452-1, EN 1329-1, EN 1453-1, EN1566-1, EN ISO 15493 and
DIN 8061/62, in rigid wall ($t_E \geq 150$ mm), pipe group 2, EI 120 - U/U

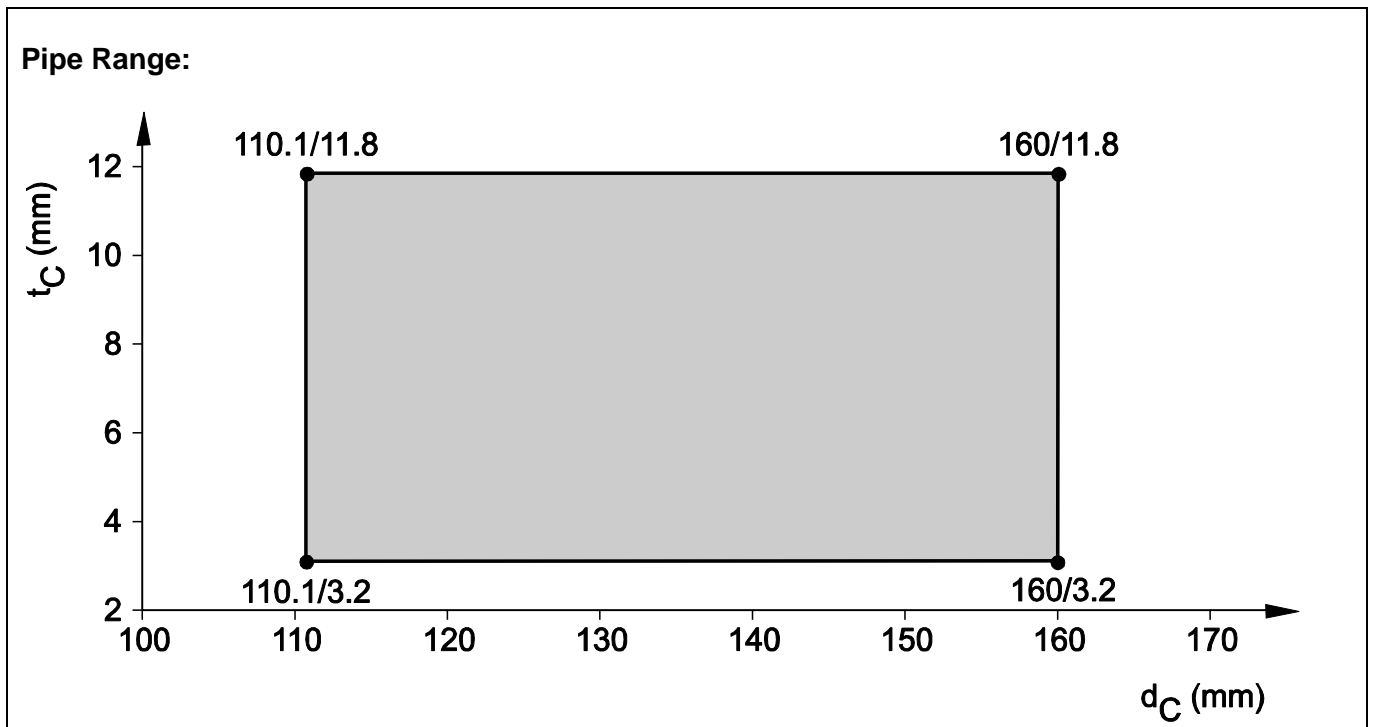

8.4.2.25 PP pipes, non-regulated, in rigid wall ($t_E \geq 150$ mm), pipe group 2, EI 120 - U/U

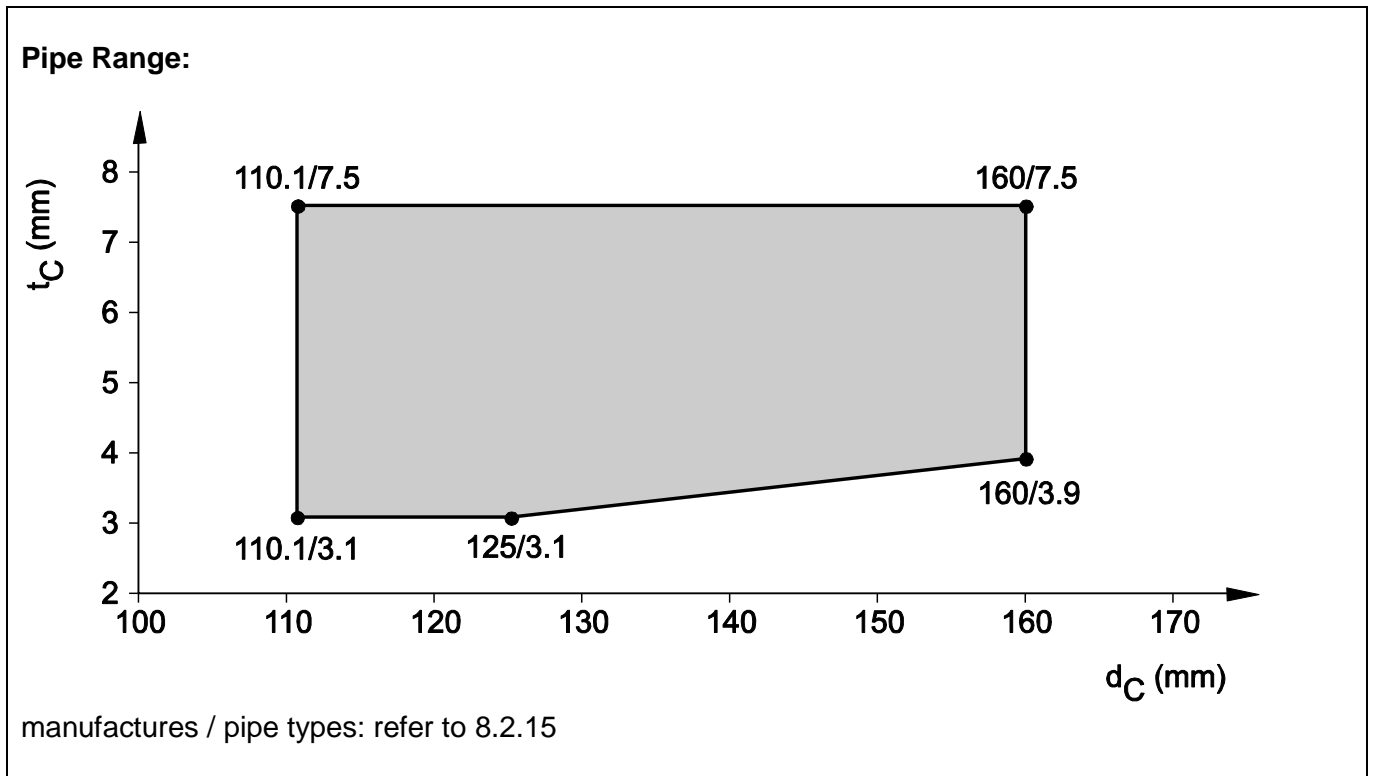

8.4.2.26 PP pipes acc. EN 1451-1 and DIN 8077/78, in rigid wall ($t_E \geq 150$ mm), pipe group 2, EI 120 - U/U

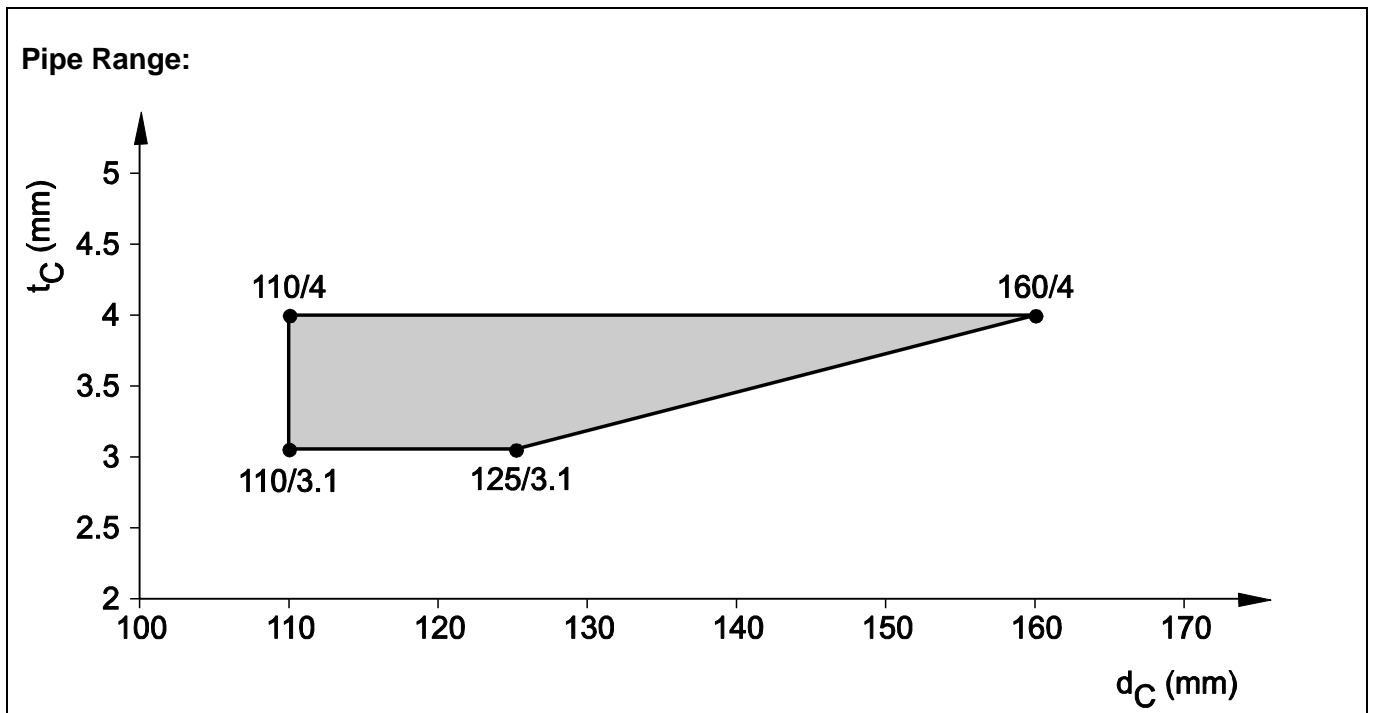

8.4.2.27 PP pipes acc. EN 1451-1 and DIN 8077/78, in rigid wall ($t_E \geq 150$ mm), pipe group 2,
EI 30 - U/U

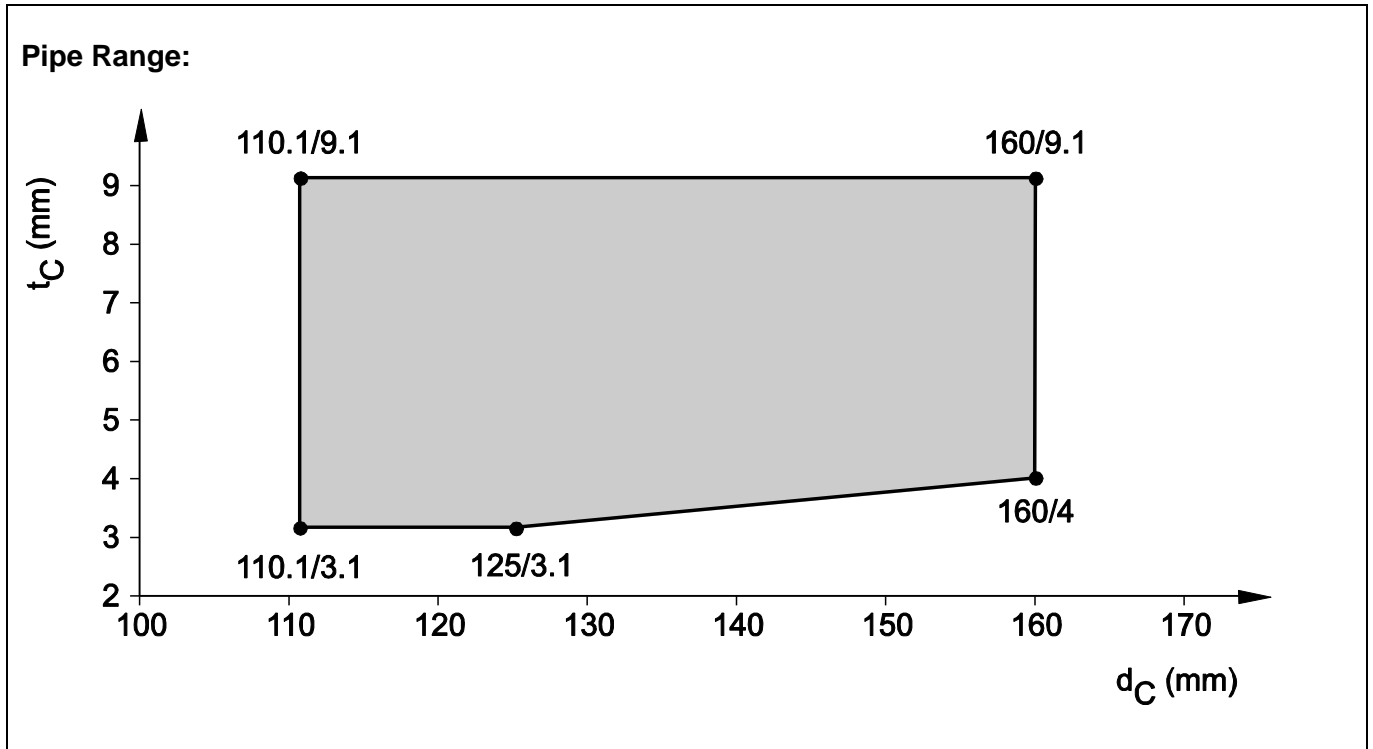

8.4.2.28 PP pipes acc. EN 1451-1 and DIN 8077/78, in rigid wall ($t_E \geq 150$ mm), pipe group 2,
EI 120 - U/C

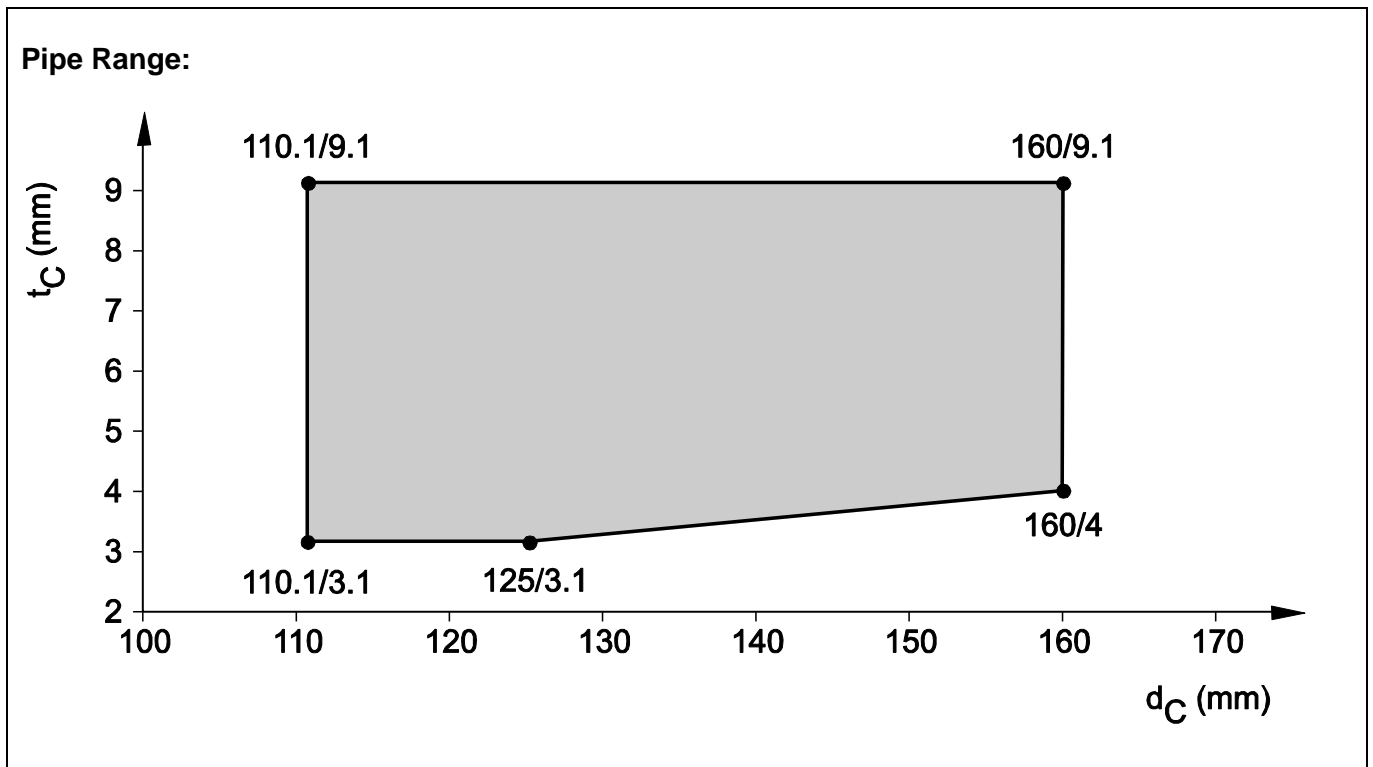

8.4.2.29 **Pneumatic dispatch system, PVC pipe acc. DIN 6660, in rigid wall ($t_E \geq 150$ mm),
pipe group 2, EI 90 - U/U**

Situation for EI 90 - U/U:

- PVC pipe acc. DIN 6660
- Pipe diameter ($110,1 \text{ mm} \leq d_C \leq 160 \text{ mm}$)
- Pipe wall thickness ($t_C = 3,2 \text{ mm}$)
- Pipe inclination: 90°
- Mixed penetration is allowed: pipe together with three cables, see below
- Cable in direct contact to pipe (single or bunched cables allowed)

Maximum cable size is:

- NYM-J 3 x 2,5 mm²
- J-Y (St) Y 6 x 2 x 0,6 mm²
- 2 x 2,5 mm²

8.4.2.30 **PE-pipes, non-regulated, (Geberit Silent dB20), in rigid wall ($t_E \geq 150$ mm), pipe group 2,
EI 120 - U/U**

Pipe Range:

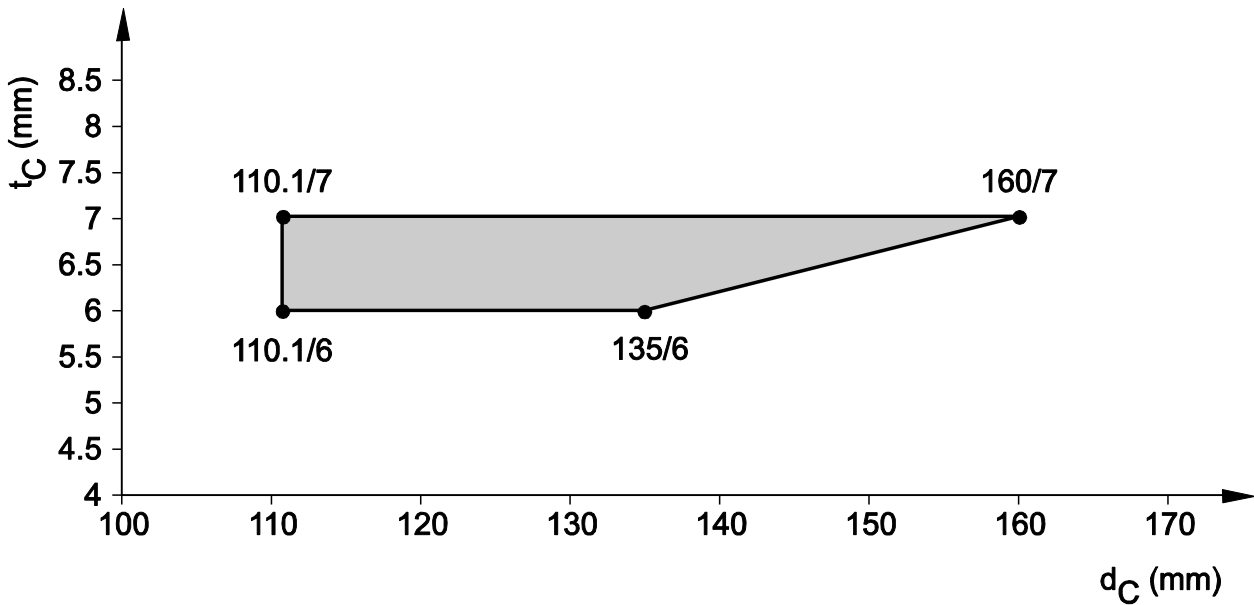

8.4.2.31 **PVC- pipes, non-regulated (Friatec Friaphon), in rigid wall ($t_E \geq 150$ mm), pipe group 2, EI 120 - U/U**

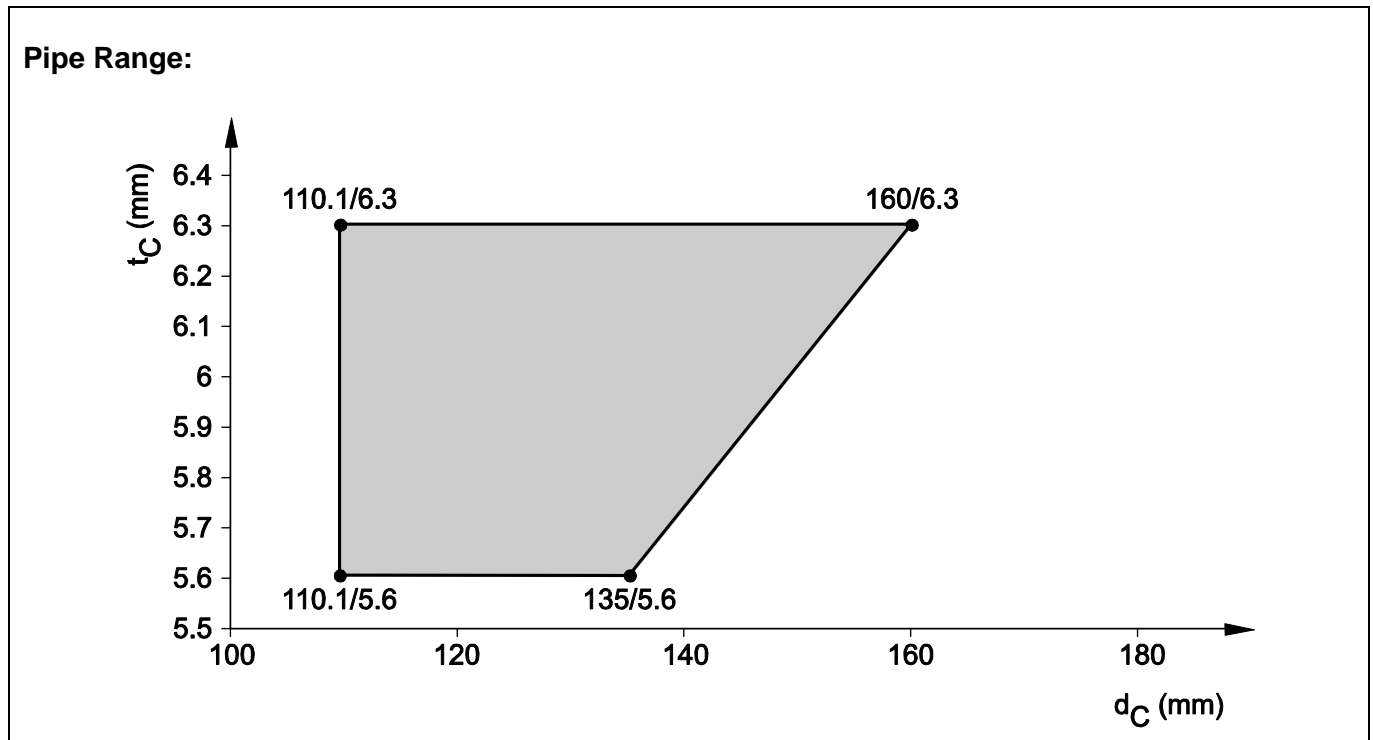

8.4.2.32 **Pipes in rigid wall ($t_E \geq 150$ mm), zero distance collar to collar, pipe group 2, EI 90 - U/U**

Situation for EI 90 - U/U (refer to 8.2.9):

- Zero distance between two CFS-C EL collars, sealing two plastic pipes ($s_1 \geq 0$ mm)
- Pipes have to be grouped in line only
- Max. 2 pipes side by side ($s_1 \geq 0$ mm) in one group
- Minimum distance group to group has to be ($s_2 \geq 60$ mm)
- Number of groups is unlimited

Type of pipes:

- refer to 8.4.2.20, 8.4.2.23, 8.4.2.24, 8.4.2.25, 8.4.2.26, 8.4.2.30

Range of pipes:

- refer to 8.4.2.20, 8.4.2.23, 8.4.2.24, 8.4.2.25, 8.4.2.26, 8.4.2.30

8.4.2.33 PP pipes acc. EN 1451-1 in rigid wall ($t_E \geq 150$ mm) pipe group 1, EI 120 - U/U,
 Pipe coupling

Situation for EI 120 - U/U:

- Pipe coupling inside the wall, half in the wall or outside the wall, covered by CFS-C EL
- Type of pipes: PP pipes acc. EN 1451-1
- Pipe insulation: see 8.2.6

Pipe range:

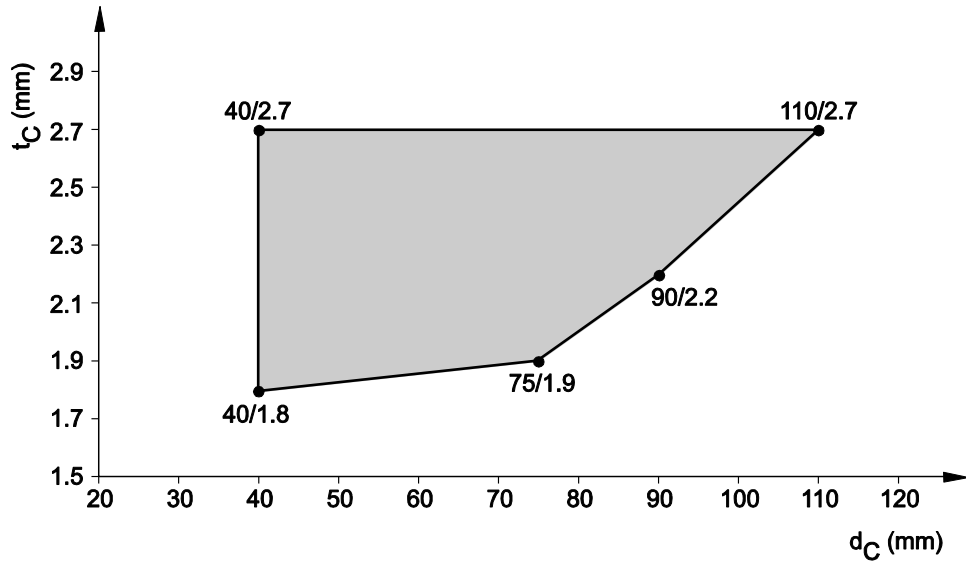

Gap size and gap filler:

In rigid wall application ($t_E \geq 150$ mm):

- Gap filler: Hilti CFS-FIL
- Annular gap: 5 – 40 mm
- Depth t_{A2} to be filled with Hilti CFS-FIL: ($t_{A2} \geq 25$ mm)
- No backfilling required

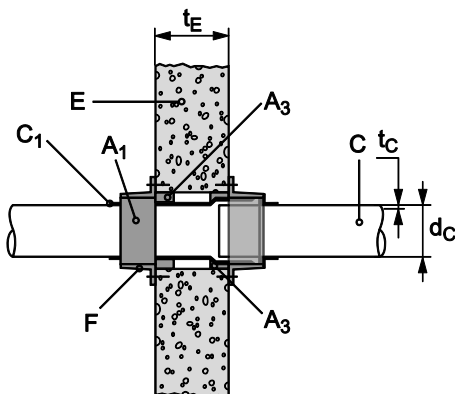

Requested number of hooks:

Pipe outside nominal diameter d_c (mm)	Acoustic Pipe Insulation Thickness t_D (mm) (incoming pipe / outgoing pipe)		
	0	4	9
40	2 / 2	2 / 2	2 / 2
41 - 75	3 / 3	3 / 3	3 / 3
76 - 90	3 / 3	3 / 3	3 / 3
91 - 110	3 / 4 (on coupling)	3 / 4	3 / 4

If pipe insulation thickness is between 0 and 4 mm use the number of hooks indicated for 4 mm.
If pipe insulation thickness is between 4 and 9 mm use the number of hooks indicated for 9 mm.

8.4.2.34 Wavin Tigris PE-X - One pipes in rigid wall ($t_E \geq 70$ mm) pipe group 1, EI 90 - U/C

Situation for EI 90 - U/C:

- Pipe (C) penetrates perpendicular the wall
- Single penetration (C) or bunched pipes
- In rigid walls ($t_E \geq 70$ mm), density ≥ 550 kg/m³
- Pipes may be sealed for single side fire load and double side fire load

Type and dimension of pipes:

- Type: Wavin Tigris PE-X-One R-I-R insulated
- For pipe dimension refer to table below
- Insulation: PE-foam, CS, for dimension refer to table below, for material refer to 8.2.13
- Additional Protection: R-I-R Hardcover, PE-HD, CS and CI, covering pipe and insulation

Nr.	Material Standard	Pipe diameter (mm)	Pipe wall thickness (mm)	Pipe insulation thickness (mm)
1	PE-X in PE Hardcover	12	2,0	9
2	PE-X in PE Hardcover	15	2,5	10
3	PE-X in PE Hardcover	18	2,5	10 - 20
4	PE-X in PE Hardcover	22	3,0	10 - 20

Gap size and Gap filler:

With mortar M10 acc. EN 998-2 (A₅):

- Annular gap width ($0 \leq s_3 \leq 15$ mm)
- Installation depth: over the entire thickness of the wall

With CFS-S ACR or CFS-IS (A₂):

- Annular gap width ($0 \leq s_3 \leq 15$ mm)
- Installation depth: min. 25 mm from both sides
- With or without backfilling B (mineral wool, density ≥ 40 kg/m³), reaction to fire class: min. A2-s1, d0

For cluster or linear arrangements:

- Triangular clusters and pipes in line (horizontal / vertical)
- Number of pipes in cluster: defined by max. collar diameter / perimeter length see below
- Minimum distance between clustered pipes: $s_2 \geq 0$ mm

Collar seal CFS-C EL:

- CFS-C EL fits tightly around the cluster or linear arrangement
- Max. collar diameter: 80 mm
- Max. collar perimeter length: 550 mm
- Fixing with 3 hooks for single and multiple penetration (clusters)

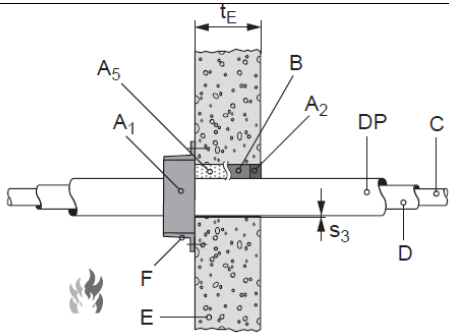

8.4.2.34 A:

Wavin Tigris PE-X-One R-I-R insulated with single-side fire load

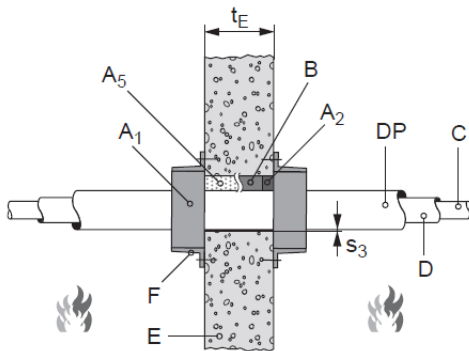

8.4.2.34 B:

Wavin Tigris PE-X-One R-I-R insulated with double-side fire load

8.5 Rigid floor

8.5.1 Specific characteristics for Rigid floor ($t_E \geq 150$ mm)

8.5.1.1 Rigid floor:

The floor must have a minimum thickness of 150 mm with a minimum density of $\rho_E \geq 650$ kg/m³ and comprise concrete, aerated concrete or masonry.

8.5.1.2 Annular gap

Annular gap around penetrating item has to be filled with:

- Cementitious mortar acc. EN 998-2 group M10 over the entire thickness of the floor or
- Hilti Firestop Acrylic Sealant CFS-S ACR (A_2) on top side of floor only with a depth of minimum ($t_{A2} \geq 25$ mm), backfilled with mineral wool or
- Hilti Firestop Acrylic Sealant CFS-S ACR (A_2) only, installation depth ($t_{A2} \geq 25$ mm), installed on both sides of floor

Annular gap width should be:

- 0 – 40 mm (when sealed with mortar group M10 acc. EN 998-2 over the entire wall thickness)
- 0 – 40 mm (when sealed with Hilti Firestop Acrylic Sealant CFS-S ACR and mineral wool backfilling)
- 0 – 15 mm (when sealed with Hilti Firestop Acrylic Sealant CFS-S ACR only)

8.5.1.3 Collar fixing

Hilti Firestop Collar Endless CFS-C EL (A_1) has to be fixed with hooks (F) on the bottom side of the floor. A collar seal is requested from the lower side only.

The requested number and type of hooks is shown in 8.2.4 and Tab.3.

Hooks fixing in rigid floor is described in 8.2.3 and Tab.2.

Bended hooks could be pressed into the wet gap seal, made of cementitious mortar. For details regarding Integrity and insulation in pipe group 1 and pipe group 2 refer to 8.5.2

Mortar must be fully cured before fire rating is available.

Plastic pipe, penetrating a rigid floor, sealed with Hilti Firestop Collar Endless CFS-C EL. Used gap filler is mortar group M10 acc. EN 998-2 over the entire wall thickness.

Plastic pipe could be covered or uncovered by an acoustical insulation.

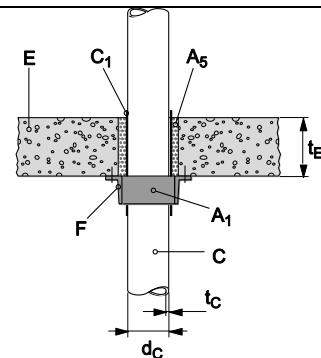

<p>Plastic pipe, penetrating a rigid floor, sealed with Hilti Firestop Collar Endless CFS-C EL. Used gap filler is CFS-S ACR in a thickness of ($t_{A2} \geq 25$ mm) from the upper surface of the floor only, backfilled with mineral wool.</p> <p>Plastic pipe could be covered or uncovered by an acoustical insulation.</p>	
<p>Plastic pipe, penetrating a rigid floor, sealed with Hilti Firestop Collar Endless CFS-C EL. Used gap filler is CFS-S ACR in a thickness of ($t_{A2} \geq 25$ mm) from both surfaces of the floor, no backfilling is requested.</p> <p>Plastic pipe could be covered or uncovered by an acoustical insulation.</p>	

8.5.2 Penetration services in rigid floor ($t_E \geq 150$ mm)

8.5.2.1 PE pipes acc. EN 1519-1, EN 12201-2 and EN 12666-1 in rigid floor ($t_E \geq 150$ mm), pipe group 1, EI 120 - U/U

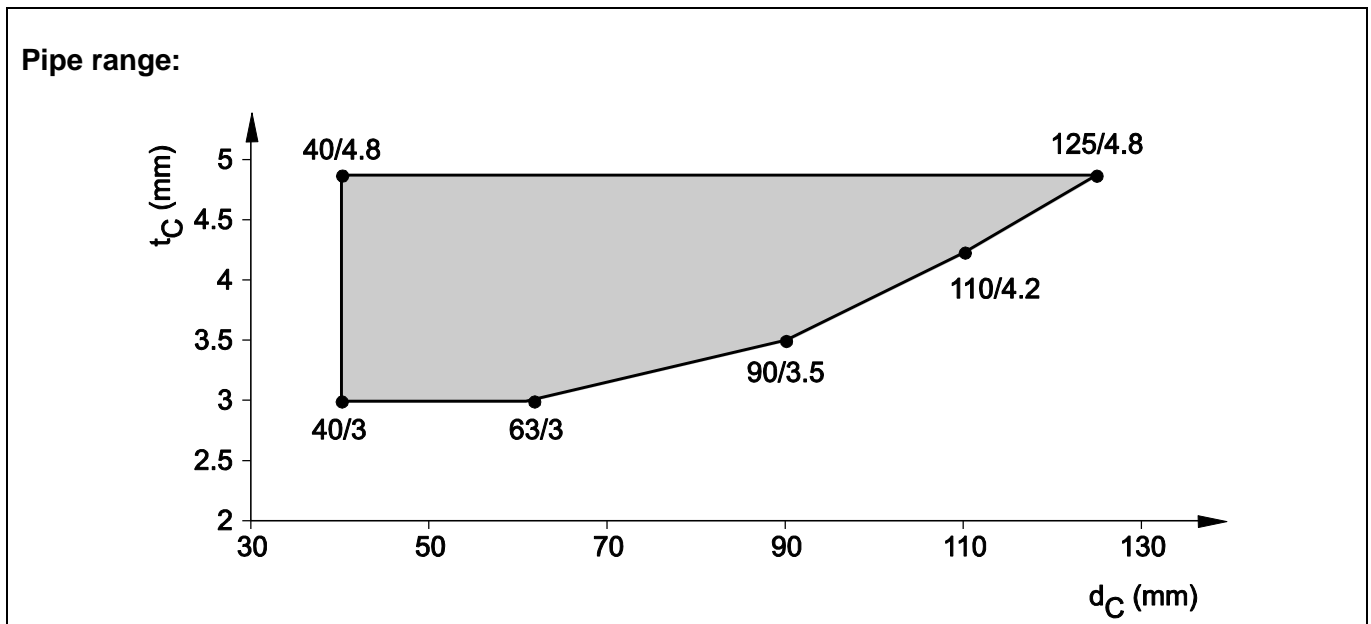

8.5.2.2 **ABS pipes acc. EN 1455-1, EN 15493 and SAN+PVC-pipes acc. EN 1565-1, in rigid floor ($t_E \geq 150$ mm), pipe group 1, EI 120 - U/U**

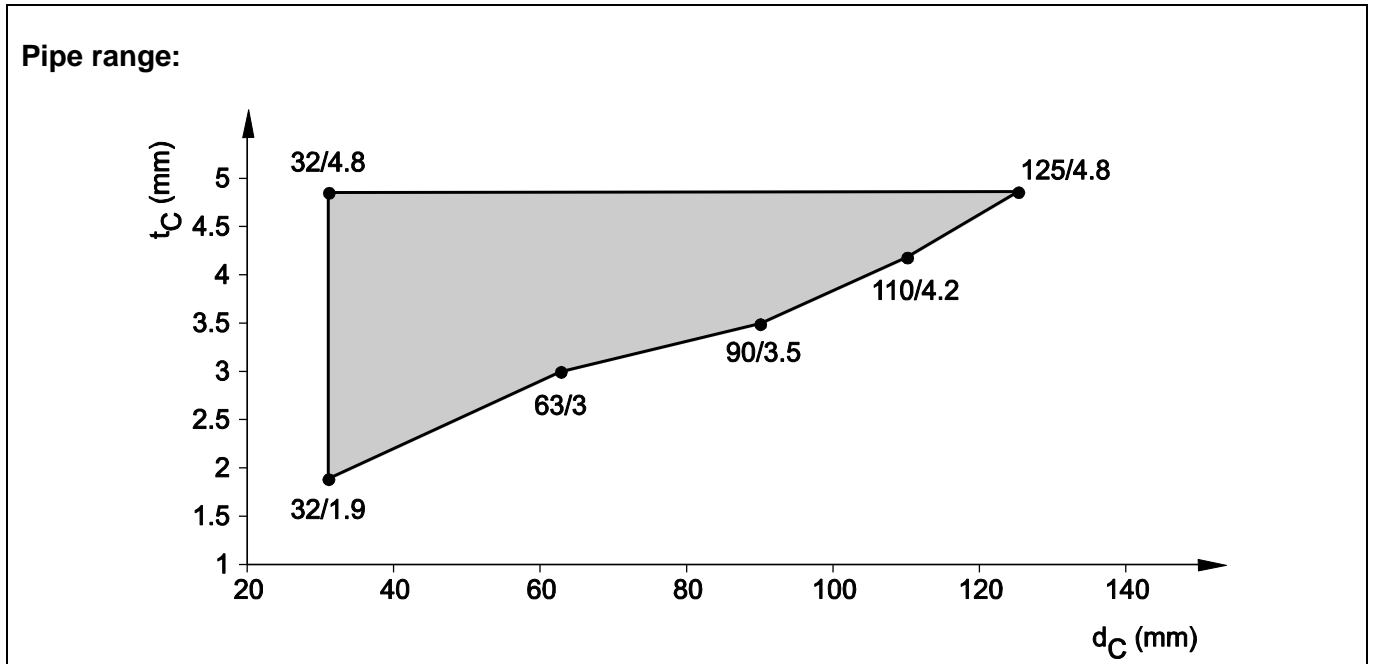

8.5.2.3 **PE pipes acc. EN 15494, EN 12201-2 and DIN 8074/75 in rigid floor ($t_E \geq 150$ mm), pipe group 1, EI 120 - U/U**

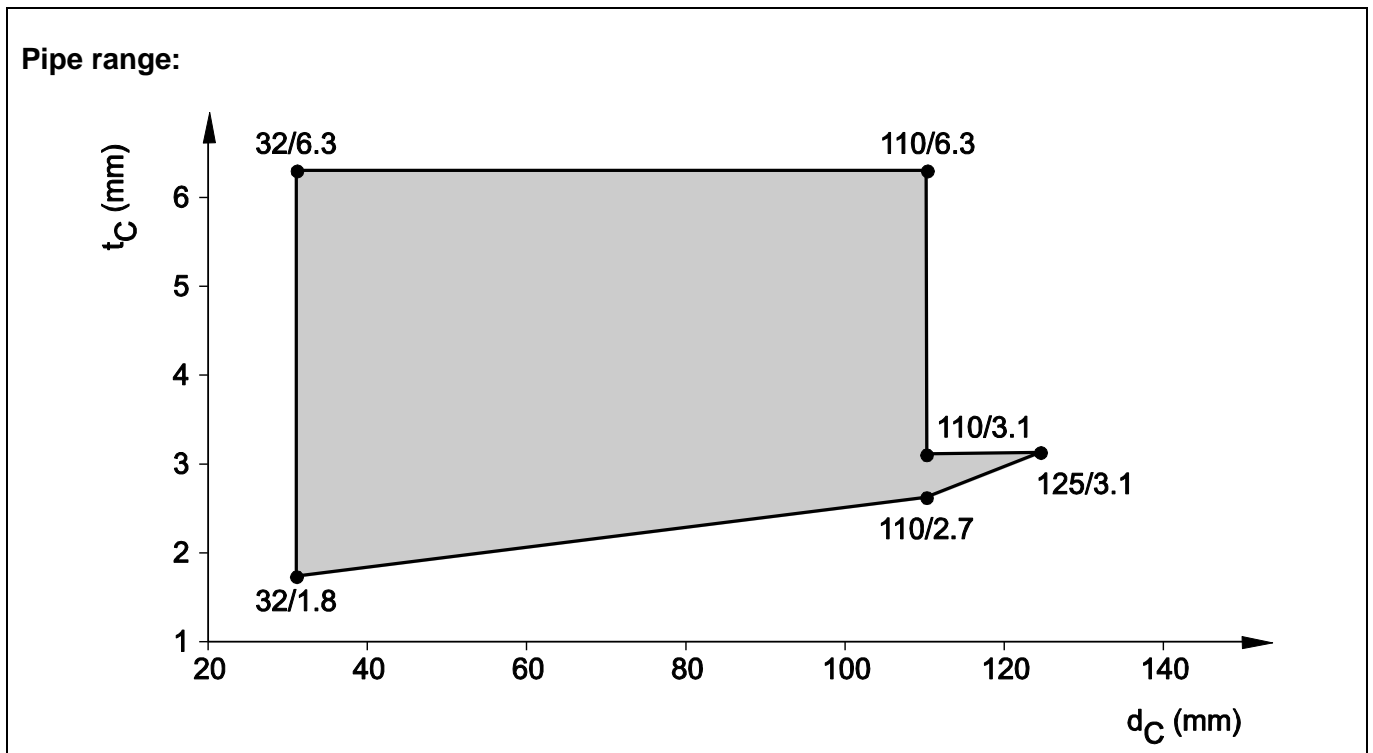

8.5.2.4 PVC pipes acc. EN 1452-1, EN 1329-1, EN 1453-1, EN 1566-1, EN ISO 15493 and
DIN 8061/62 in rigid floor ($t_E \geq 150$ mm), pipe group 1, EI 120 - U/U

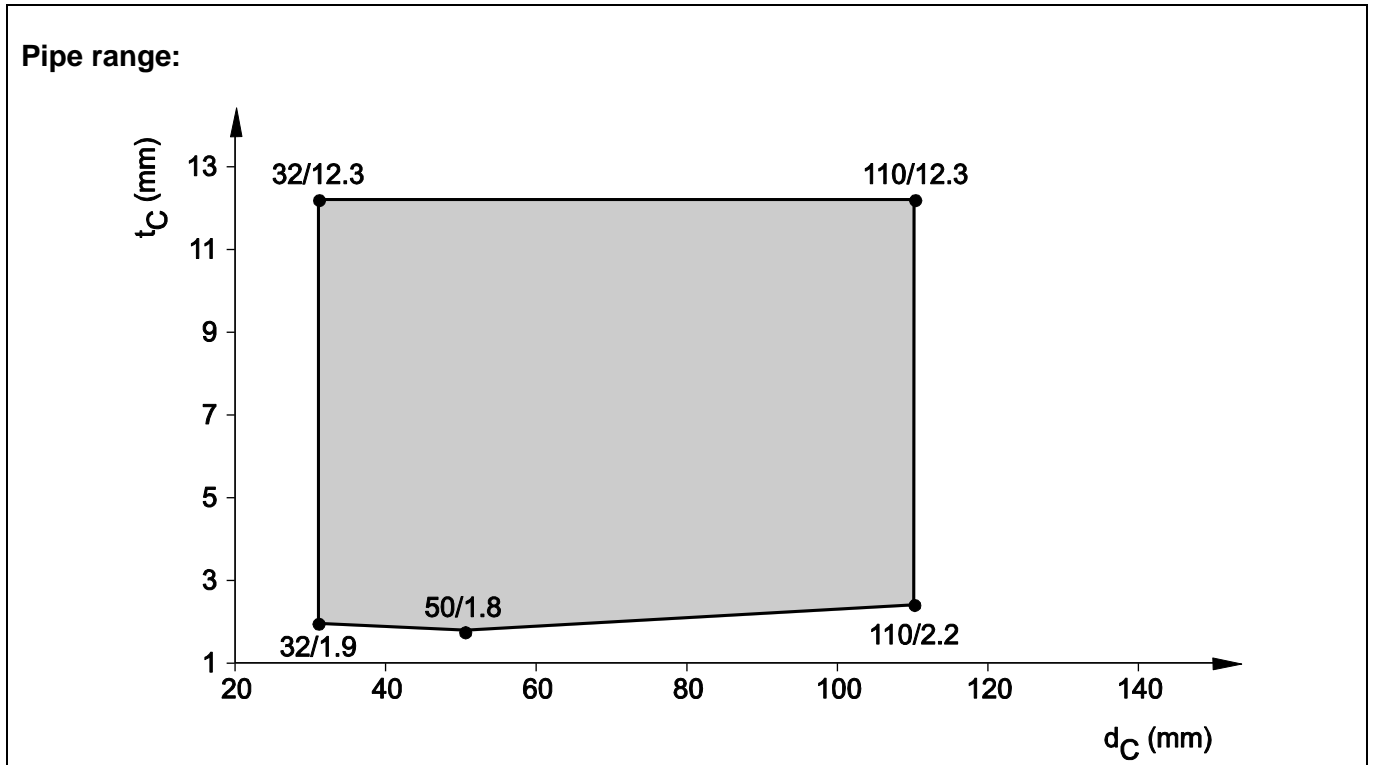

8.5.2.5 PVC pipes acc. EN 1452-1, EN 1329-1, EN 1453-1, EN 1566-1, EN ISO 15493 and
DIN 8061/62, in rigid floor ($t_E \geq 150$ mm), pipe group 1, EI 90 - U/U

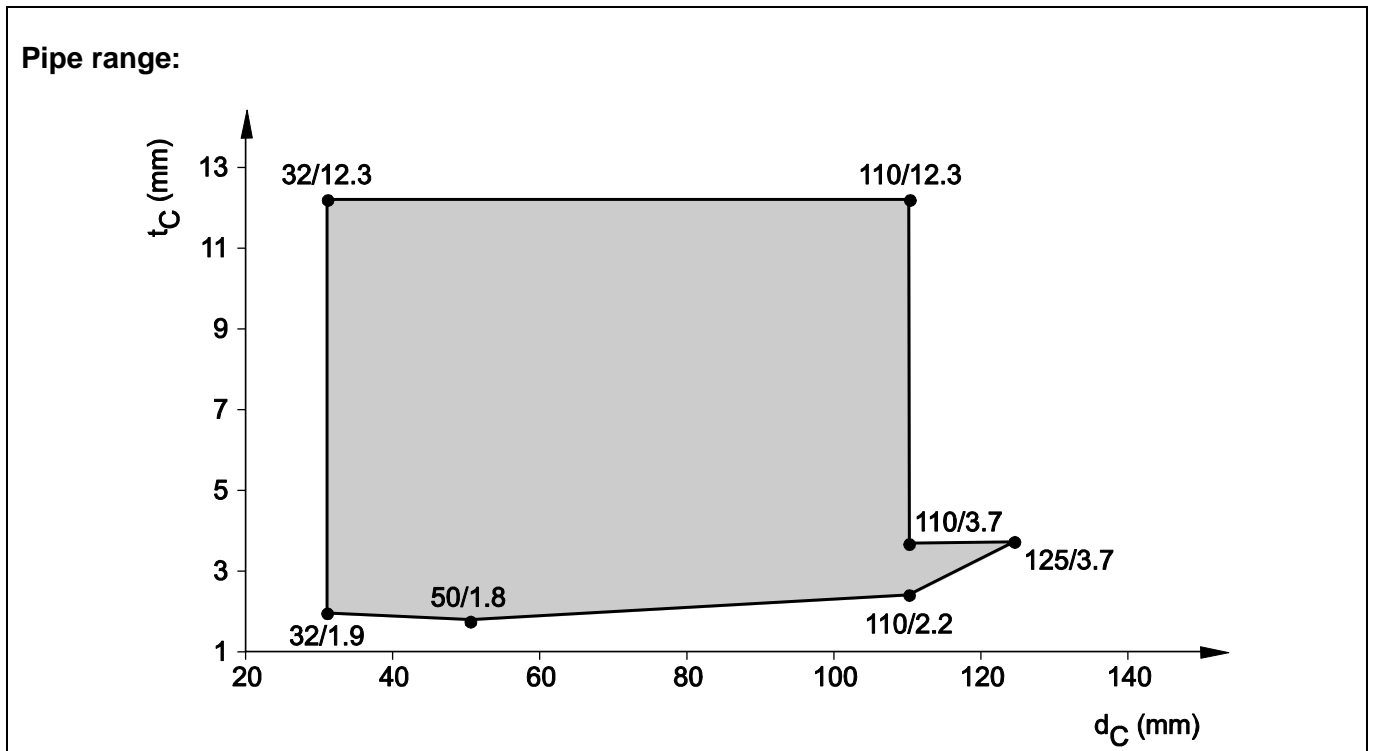

8.5.2.6 **PP pipes, non-regulated, pipe types: refer to 8.2.15, in rigid floor ($t_E \geq 150$ mm), pipe group 1, EI 120 - U/U**

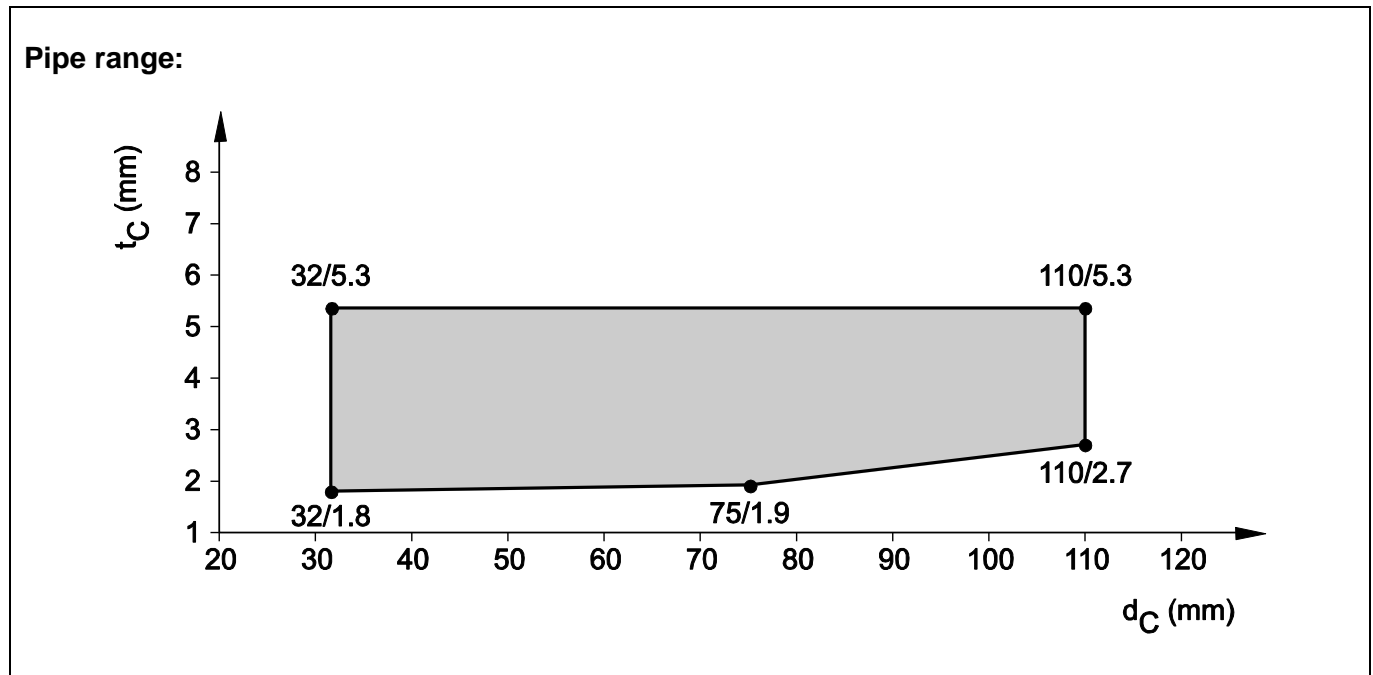

8.5.2.7 **PP pipes acc. EN 1451-1 and DIN 8077/78, in rigid floor ($t_E \geq 150$ mm), pipe group 1, EI 120 - U/U**

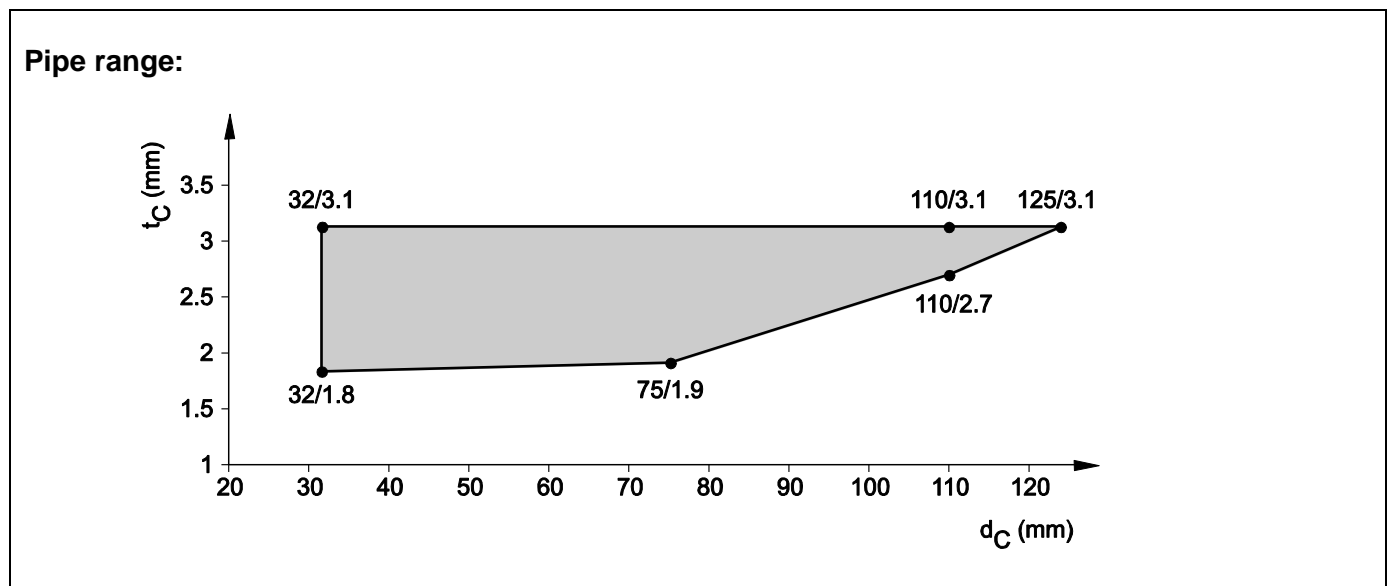

8.5.2.8 **PP pipes acc. EN 1451-1 and DIN 8077/78, in rigid floor ($t_E \geq 150$ mm), pipe group 1, EI 90 - U/U**

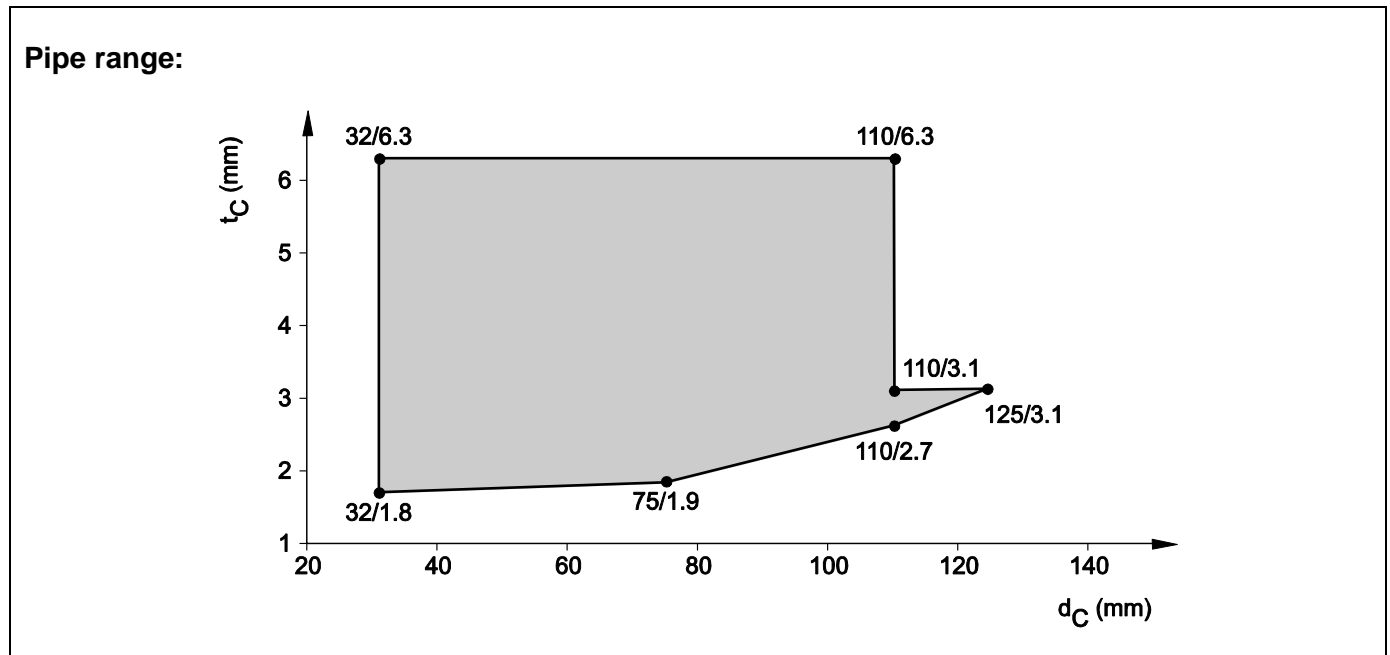

8.5.2.9 **PP pipes acc. EN 1451-1 and DIN 8077/78, in rigid floor ($t_E \geq 150$ mm), pipe group 1, EI 120 - U/C**

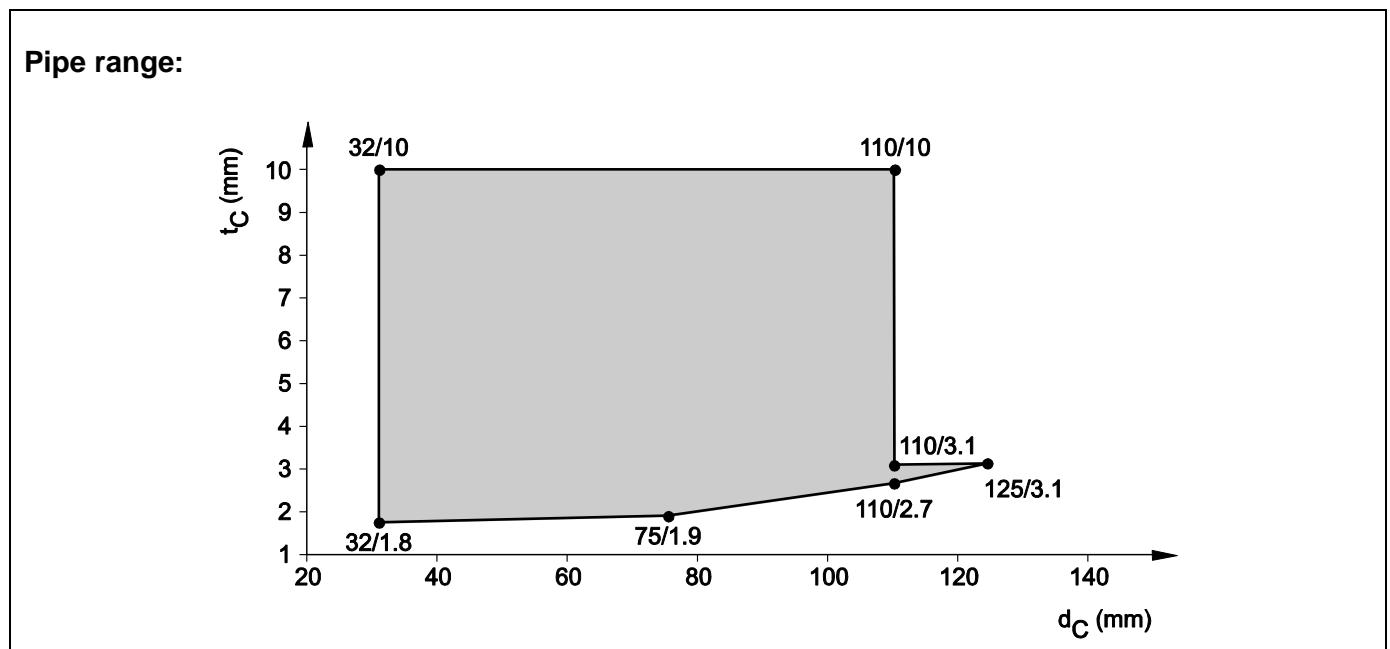

8.5.2.10 PE pipes, non-regulated (Geberit Silent dB20), in rigid floor ($t_E \geq 150$ mm), pipe group 1, EI 120 - U/U

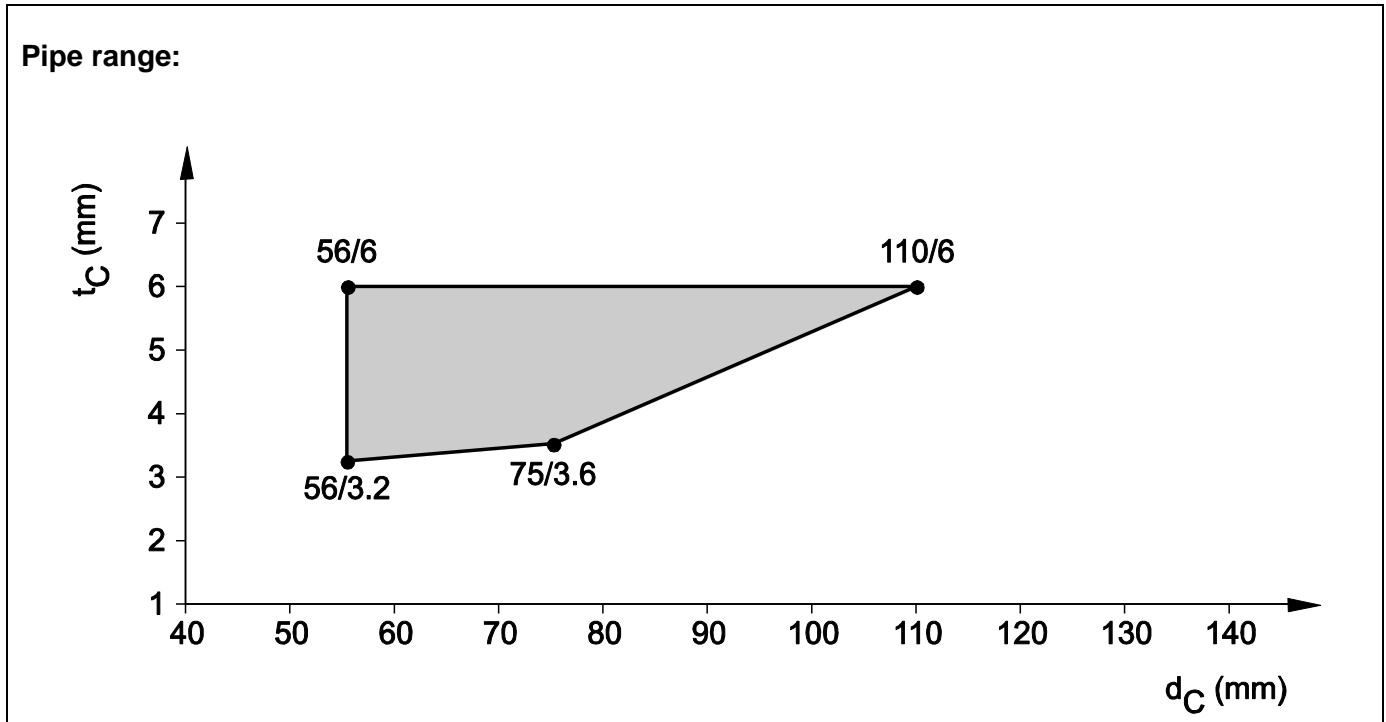

8.5.2.11 PVC-pipes, non-regulated (Friatec Friaphon), in rigid floor ($t_E \geq 150$ mm), pipe group 1, EI 180 - U/U

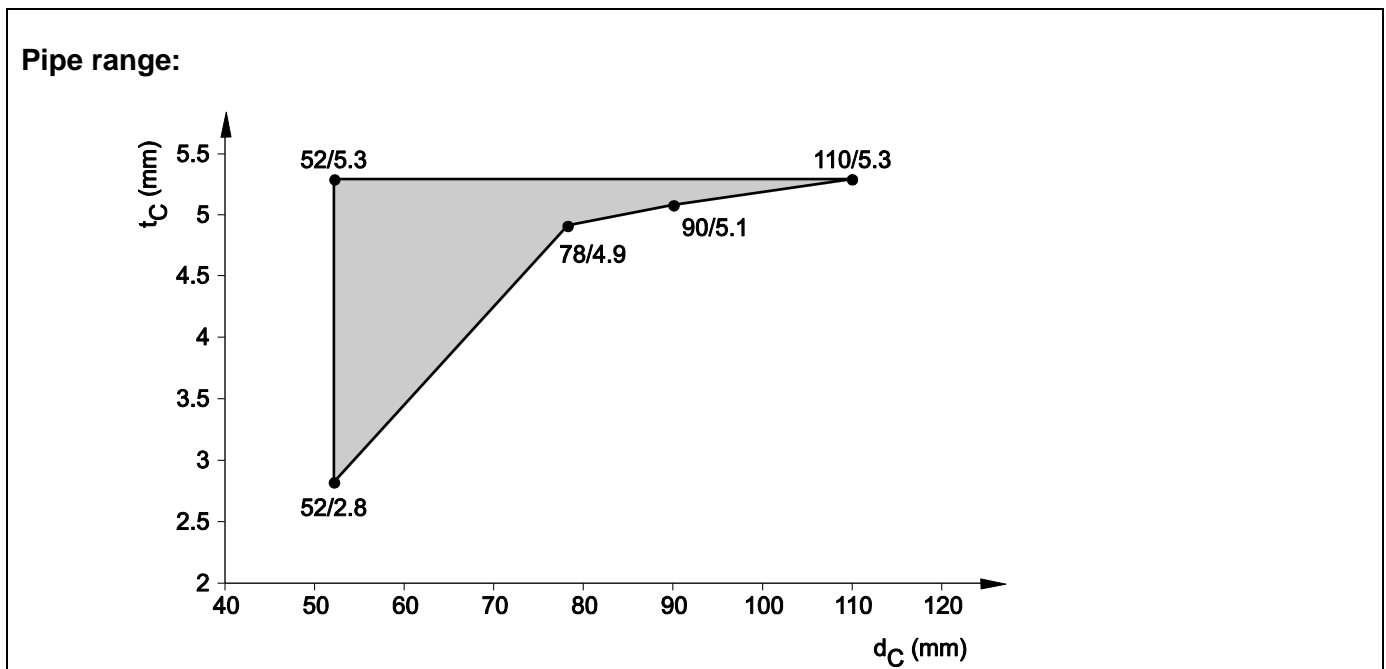

8.5.2.12 **Pneumatic dispatch system, PVC-U pipes acc. DIN 6660, in rigid floor ($t_E \geq 150$ mm), pipe group 1, EI 120 - U/U, Pipe inclination: ($45^\circ \leq$ pipe inclination $\leq 90^\circ$)**

Situation for EI 120-U/U:

- PVC pipe acc. DIN 6660
- Pipe diameter ($d_C \leq 110$ mm)
- Pipe wall thickness ($t_C = 2,3$ mm)
- Pipe inclination: ($45^\circ \leq$ pipe inclination $\leq 90^\circ$)
- Mixed penetration is allowed: pipe together with maximum three cables, see below
- Cable in direct contact to pipe (single or bunched cables tested)

Maximum cable size is:

- NYM-J 3 x 2,5 mm²
- J-Y (St) Y 6 x 2 x 0,6 mm²
- 2 x 2,5 mm²

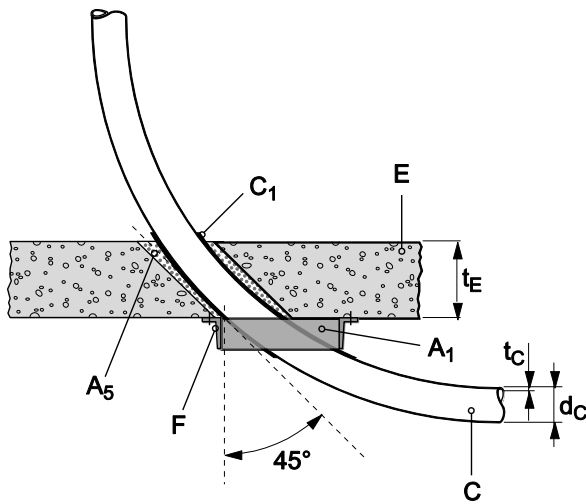

8.5.2.13 **PE pipes, non-regulated (Geberit Silent dB20), in rigid floor ($t_E \geq 150$ mm), pipe group 1, EI 120 - U/U, straight (90°), 2 x 45° elbow pipe connector**

Situation for Geberit Silent dB20 EI 120 - U/U:

- Pipe elbow connector (2 pieces each of 45°) made of PE only with electric welding wire inside
- Pipe elbow connector (2 x 45°) is allowed to be inside the floor or directly above/below the floor, covered by CFS-C EL on the bottom side of floor only
- By using 2 x 45° elbow device the penetrating pipe may run horizontal on soffit in zero distance to basement ($s_3 \geq 0$ mm)

Pipe:

- Material PE, type of pipe: Geberit Silent dB20
- Elbow connector 45° : Geberit Silent dB20 based on PE, electro-welding wire inside
- Pipe outside diameter is ($d_C = 110$ mm)
- Pipe wall thickness ($t_C = 6$ mm)

Gap size and Gap filler:

- Refer to 8.5.1.2

Number of hooks for 2 x 45° elbow application:

- Refer to 8.5.2.32

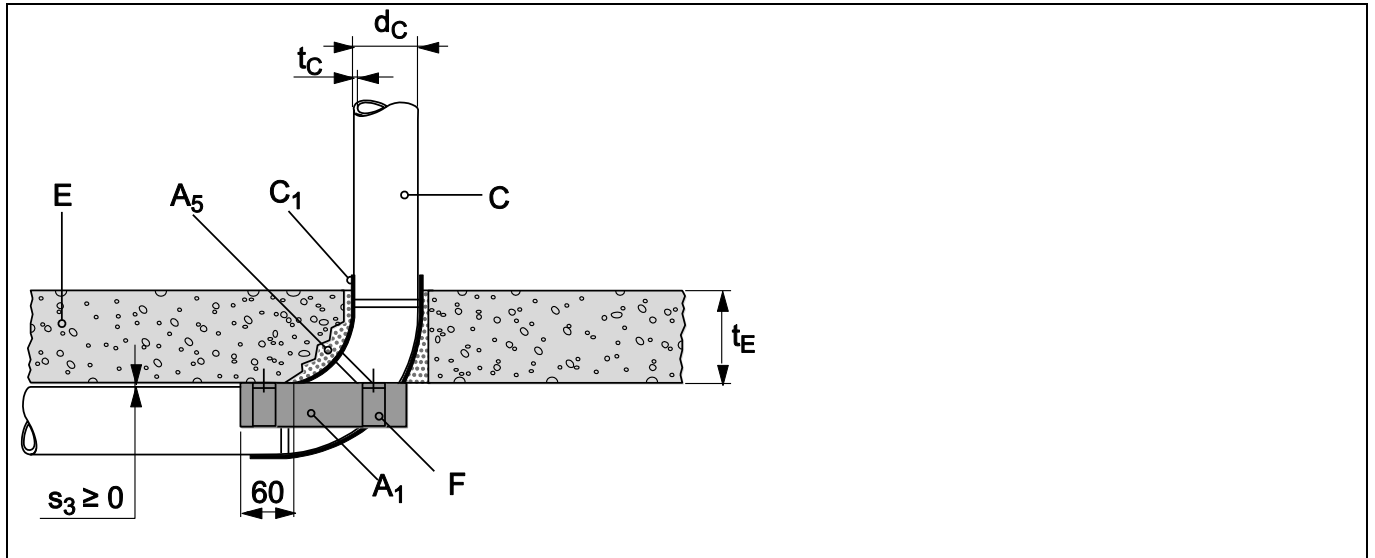

8.5.2.14 PE pipes, non-regulated (Geberit Silent dB20), in rigid floor ($t_E \geq 150$ mm), pipe group 1, EI 120 - U/U straight (90°), pipe coupling

Situation for Geberit Silent dB20 EI 120-U/U:

- Pipe coupling made of PE, with electric welding wire inside
- Perpendicular installation

Pipe:

- Material PE, type of pipe: Geberit Silent dB20
- Pipe coupling: Geberit Silent dB20 based on PE, electro-welding wire inside
- Pipe outside diameter is ($d_c = 110$ mm)
- Pipe wall thickness ($t_c = 6$ mm)

Gap size and Gap filler:

- Refer to 8.5.1.2

Number of hooks for pipe coupling application:

- refer to 8.5.2.35

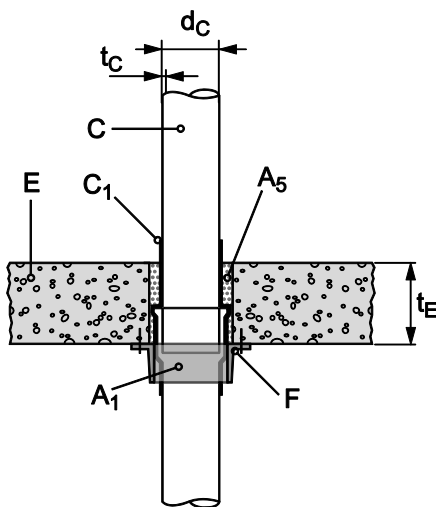

8.5.2.15 PE pipes acc. EN 1519-1, EN 12201-2 and EN 12666-1, in rigid floor ($t_E \geq 150$ mm),
pipe group 2, EI 120 - U/U

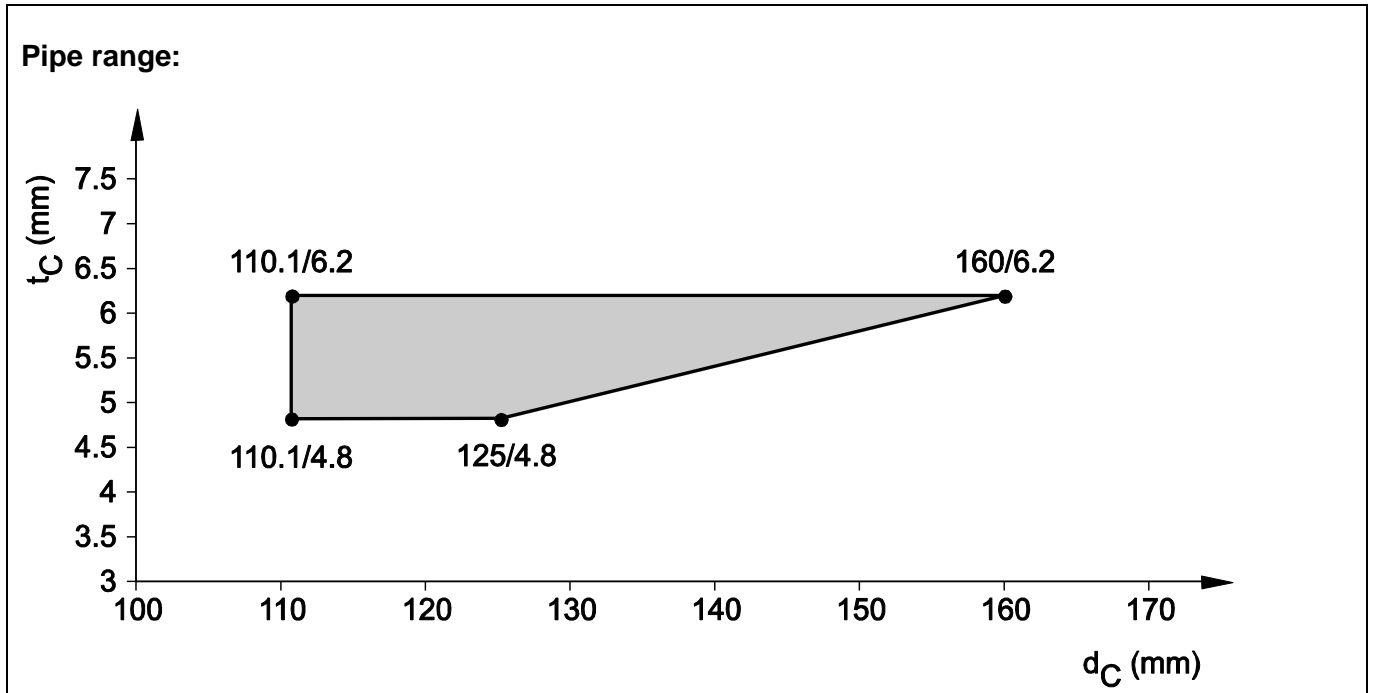

8.5.2.16 ABS pipes acc. EN 1455-1, EN 15493 and SAN+PVC-pipes acc. EN 1565-1, in rigid floor
($t_E \geq 150$ mm), pipe group 2, EI 120 - U/U

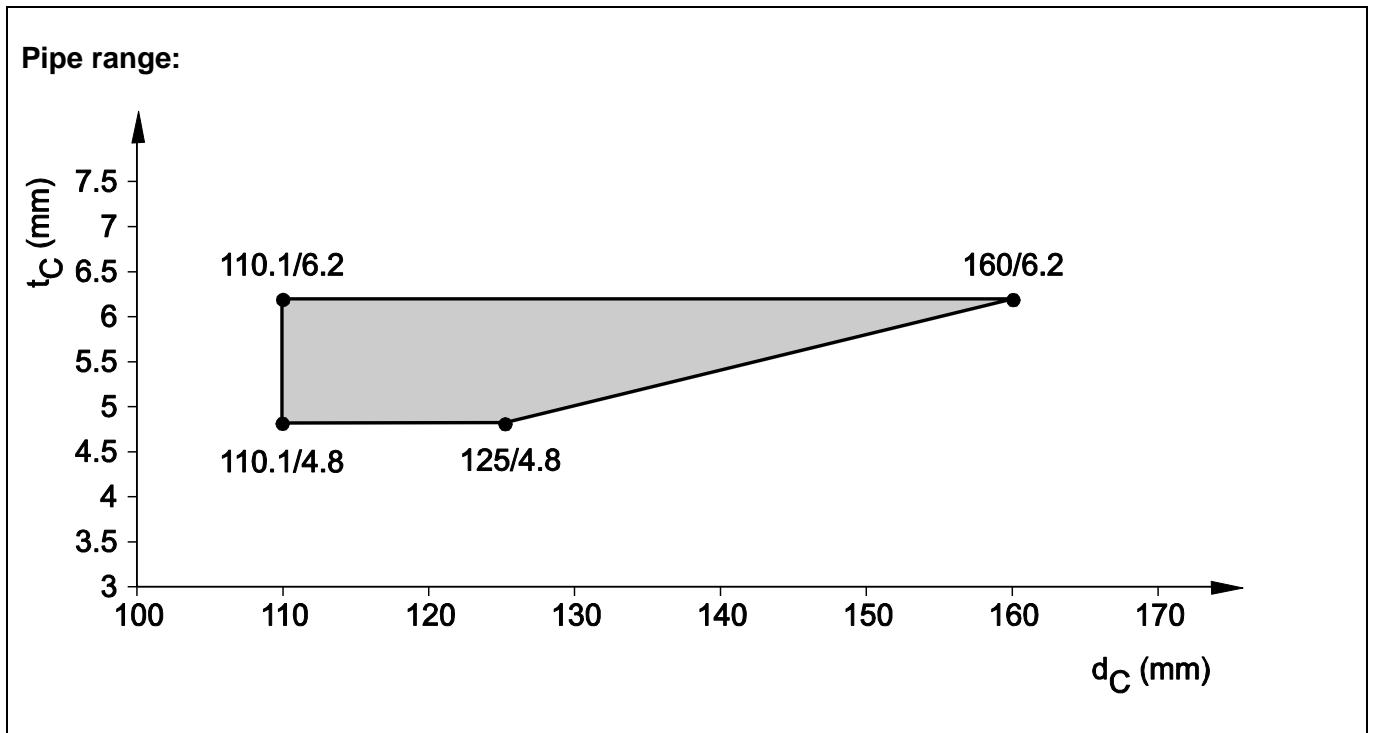

8.5.2.17 **ABS pipes acc. EN 1455-1, EN 15493 and SAN+PVC-pipes acc. EN 1565-1, in rigid floor ($t_E \geq 150$ mm), pipe group 2, EI 60 - U/U**

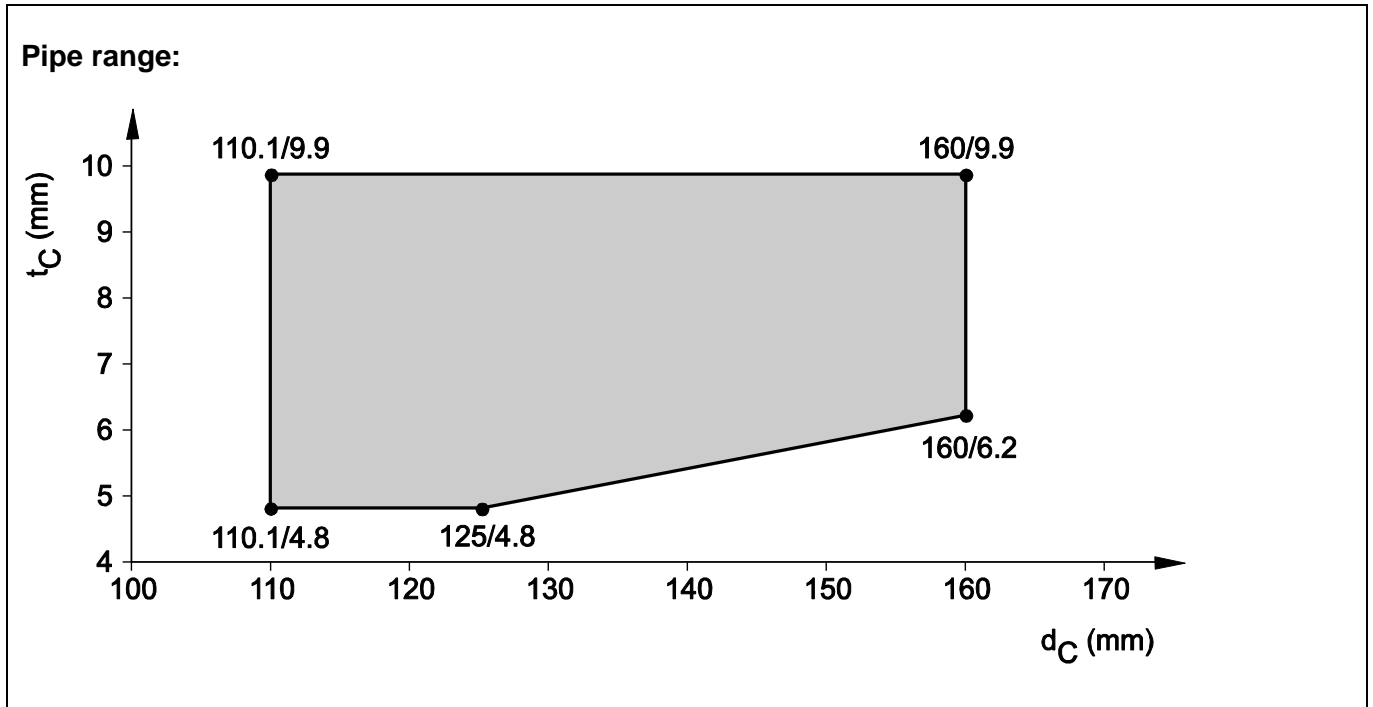

8.5.2.18 **PE pipes acc. EN 15494, EN 12201-2 and DIN 8074/75, in rigid floor ($t_E \geq 150$ mm), pipe group 2, EI 90 - U/U**

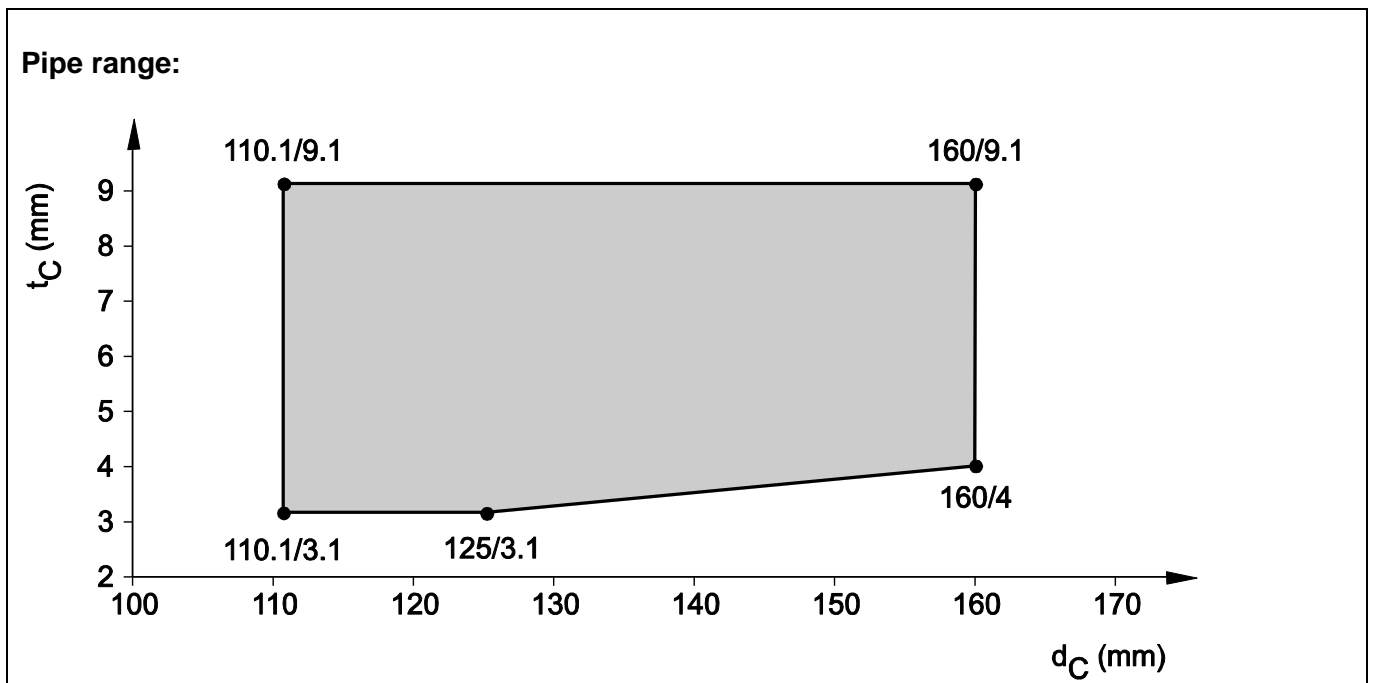

8.5.2.19 PE pipes acc. EN 15494, EN 12201-2 and DIN 8074/75, in rigid floor ($t_E \geq 150$ mm),
pipe group 2, EI 120 - U/C

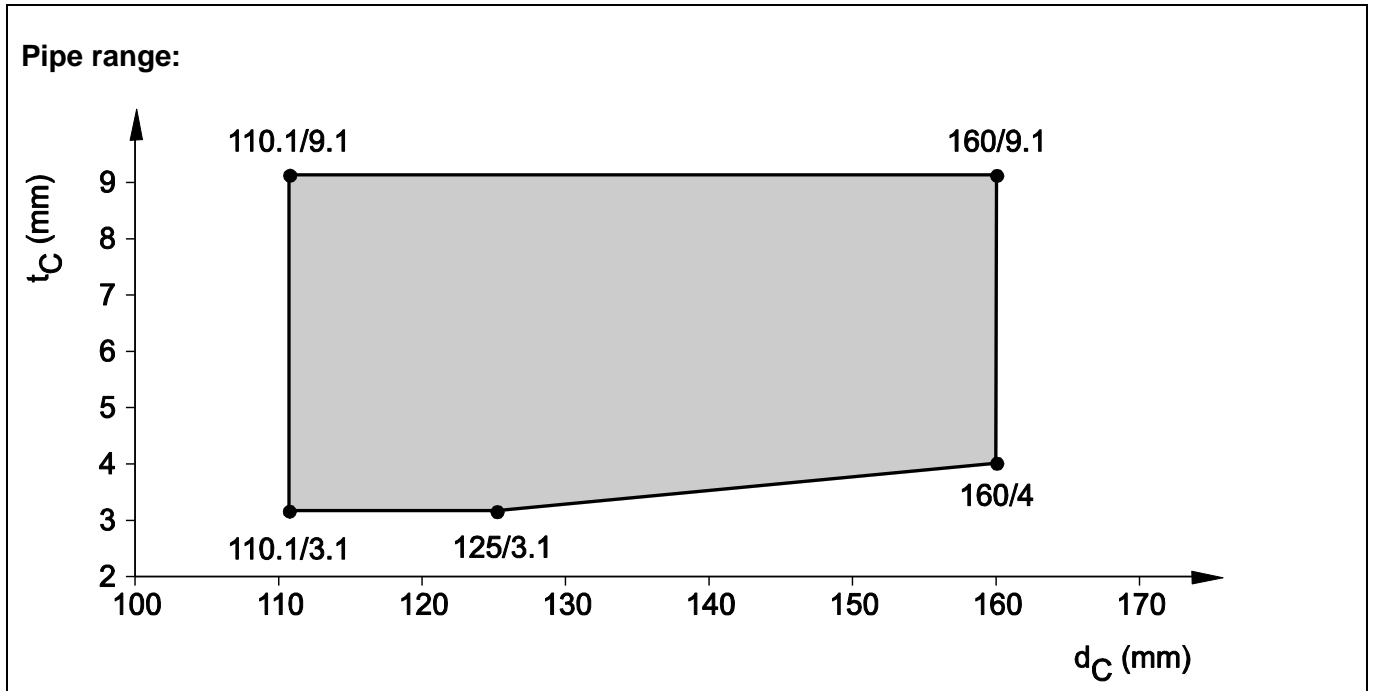

8.5.2.20 PE pipes acc. EN 15494, EN 12201-2 and DIN 8074/75, in rigid floor ($t_E \geq 150$ mm),
pipe group 2, EI 120 - U/U

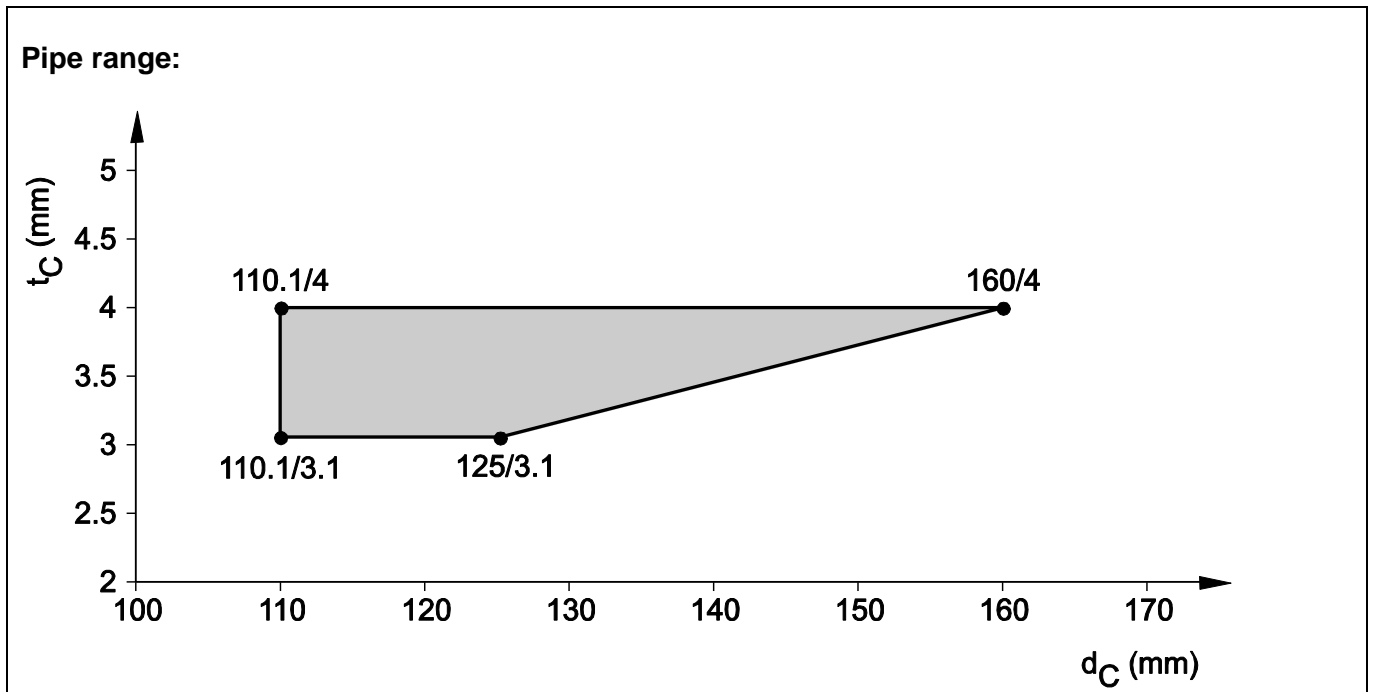

8.5.2.21 PVC pipes acc. EN 1452-1, EN 1453-1, EN 1566-1, EN 1329-1, EN ISO 15493 and
DIN 8061/62, in rigid floor ($t_E \geq 150$ mm), pipe group 2, EI 90 - U/U

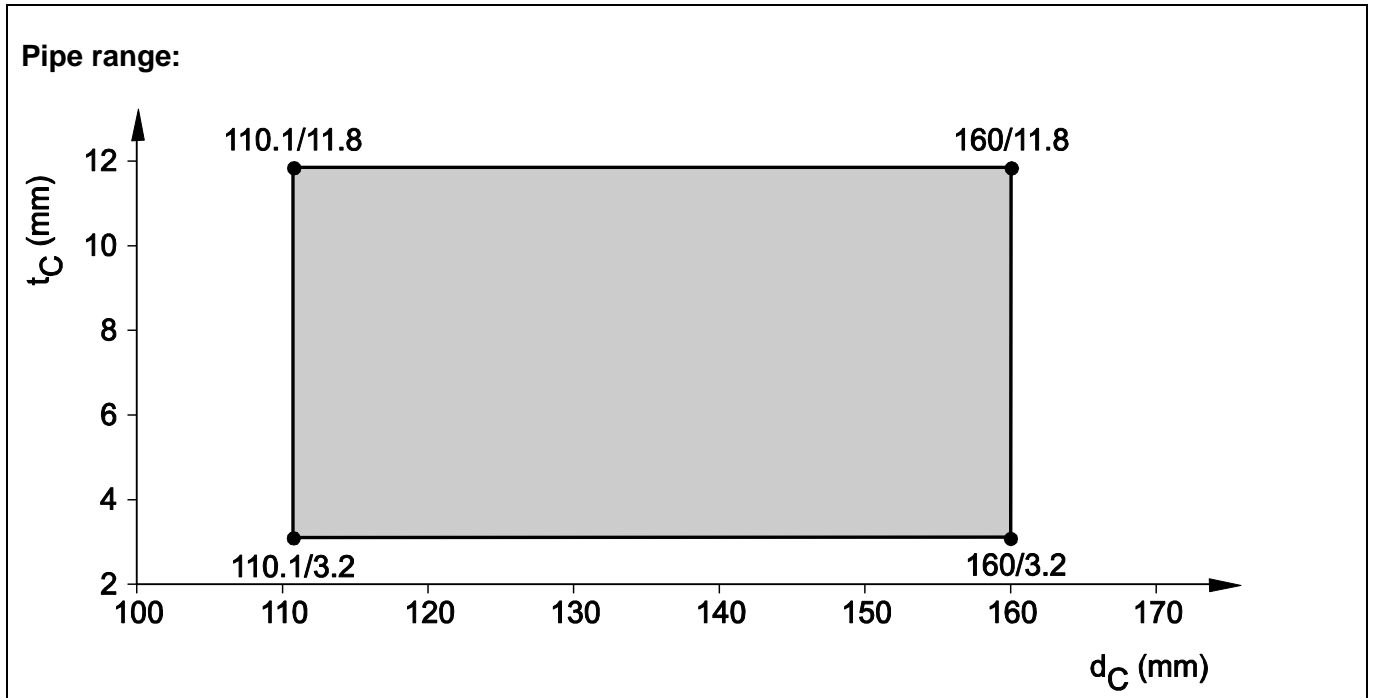

8.5.2.22 PP pipes, non-regulated, in rigid floor ($t_E \geq 150$ mm), pipe group 2, EI 120 - U/U

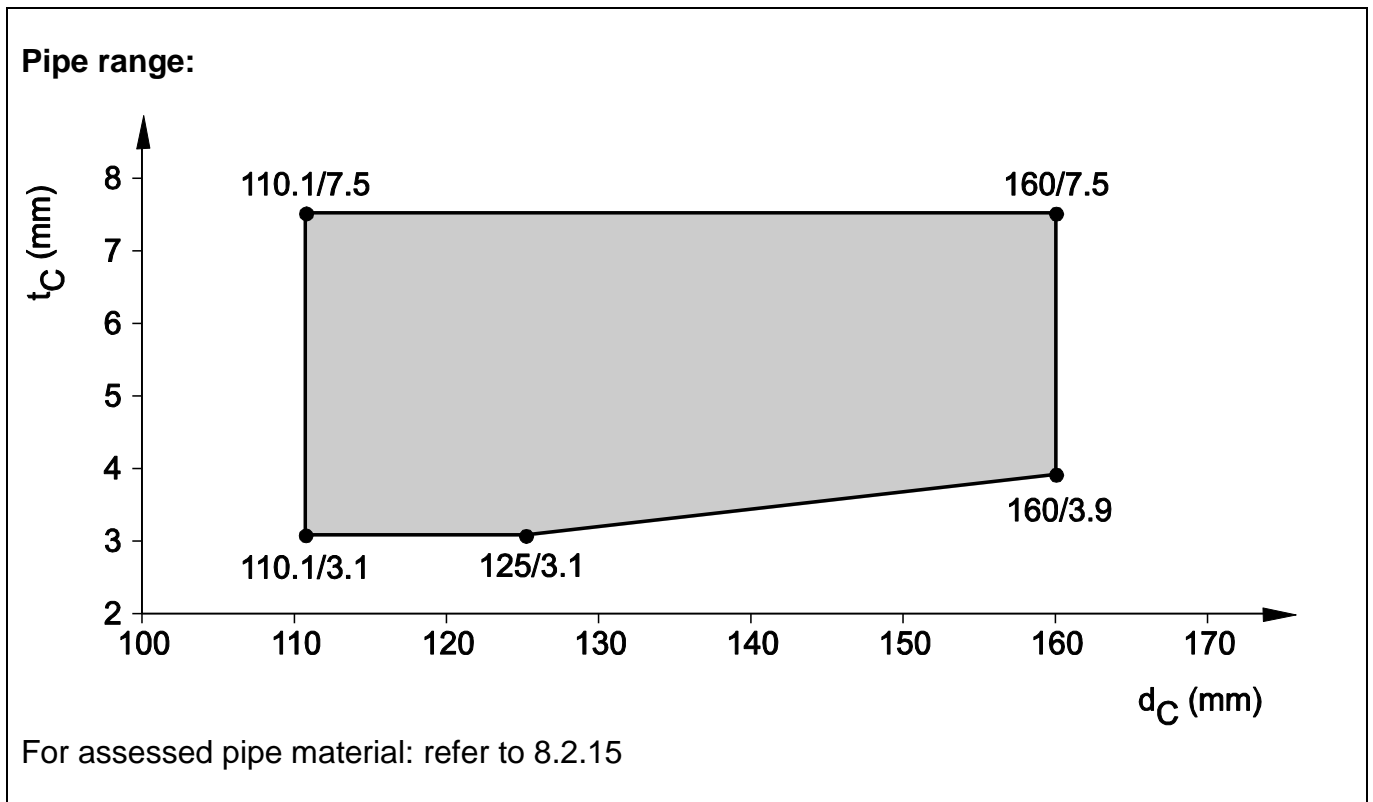

8.5.2.23 **PP pipes acc. EN 1451-1 and DIN 8077/78, in rigid floor ($t_E \geq 150$ mm), pipe group 2, EI 120 - U/U**

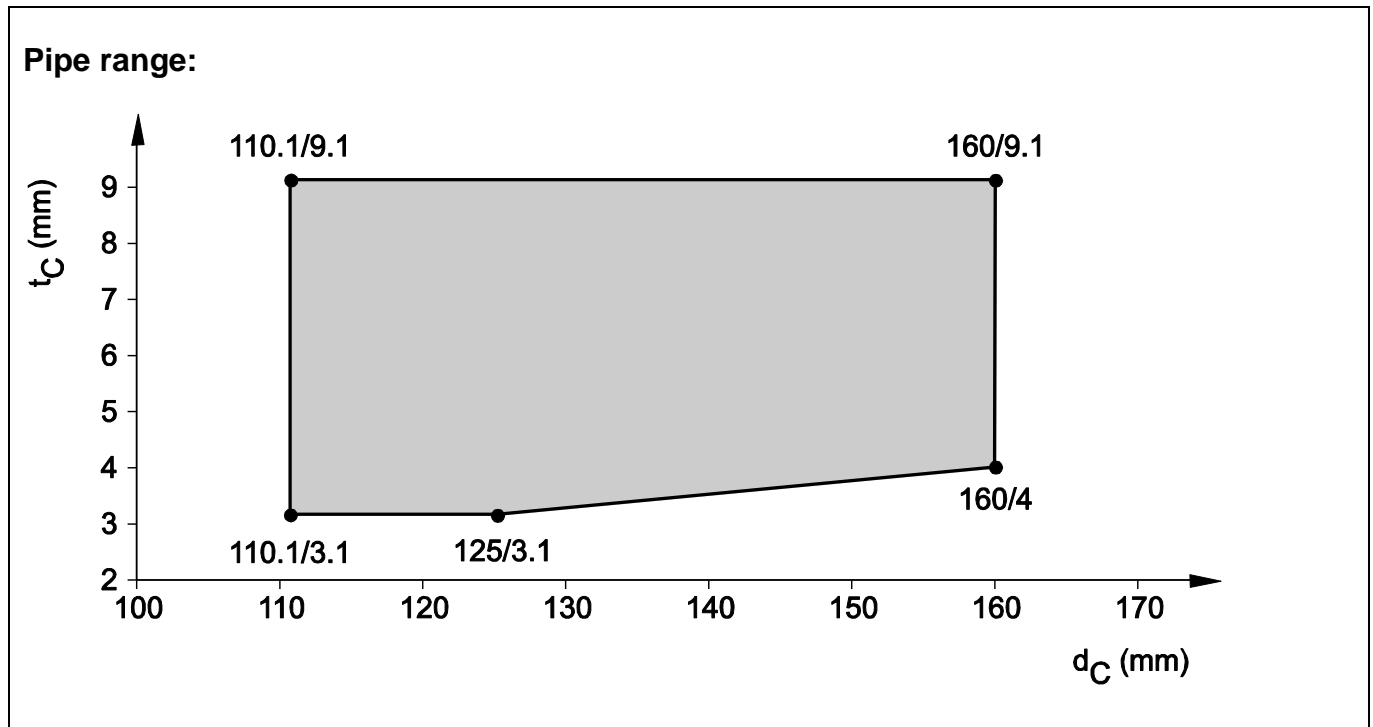

8.5.2.24 **Pneumatic dispatch system, PVC-U pipes acc. DIN 6660, in rigid floor ($t_E \geq 150$ mm), pipe group 2, EI 120 - U/U, straight (90°) installed**

Situation for EI 120-U/U:

- PVC pipe acc. DIN 6660
- Pipe diameter ($110,1 \leq d_C \leq 160$ mm)
- Pipe wall thickness ($t_C = 3,2$ mm)
- Pipe inclination: 90°
- Mixed penetration is allowed: pipe together with maximum three cables, see below
- Cable in direct contact to pipe (single or bunched cables allowed)

Maximum cable size is:

- NYM-J 3 x 2,5 mm²
- J-Y (St) Y 6 x 2 x 0,6 mm²
- 2 x 2,5 mm²

8.5.2.25 PE pipes, non-regulated (Geberit Silent dB20), in rigid floor ($t_E \geq 150$ mm), pipe group 2, EI 120 - U/U

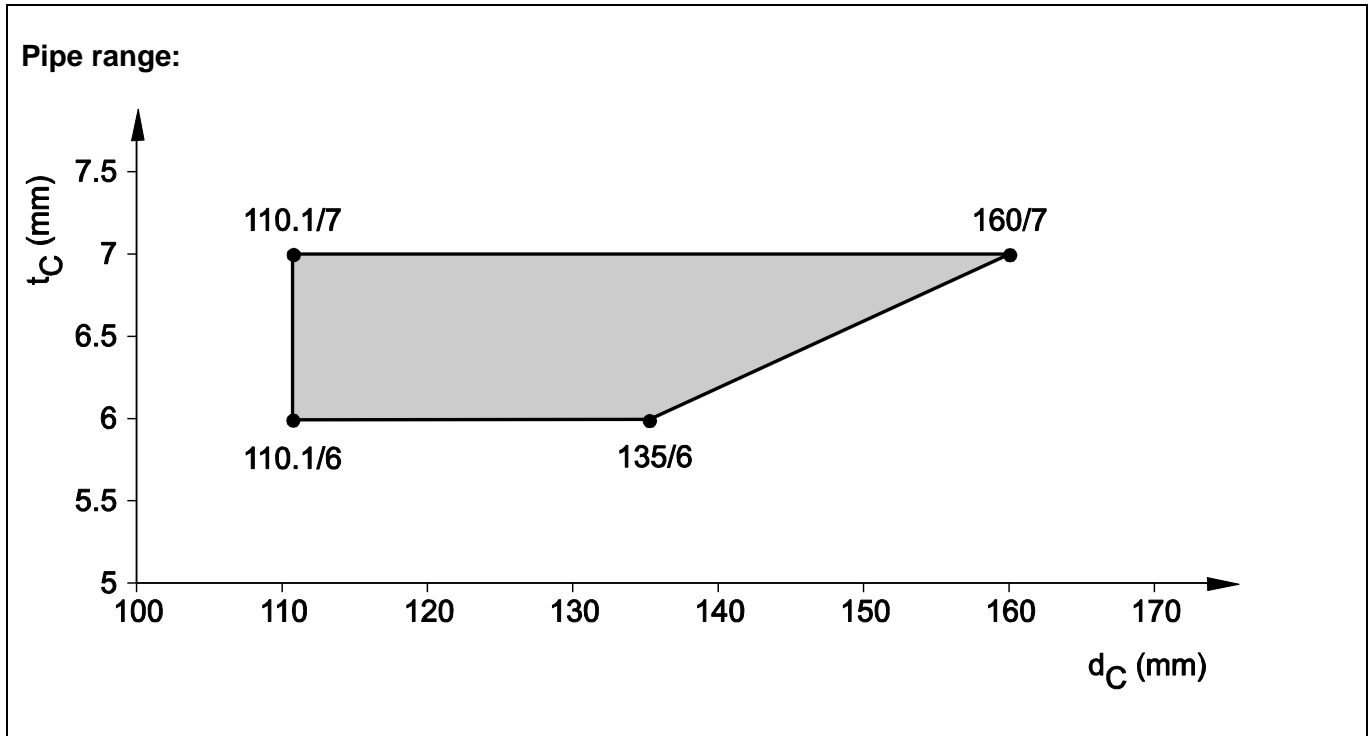

8.5.2.26 PVC pipes acc. EN 1452-1, EN 1329-1, EN 1453-1, EN 1566-1, EN ISO 15493 and DIN 8061/62, in rigid floor ($t_E \geq 150$ mm), pipe group 2, EI 120 - U/C situation

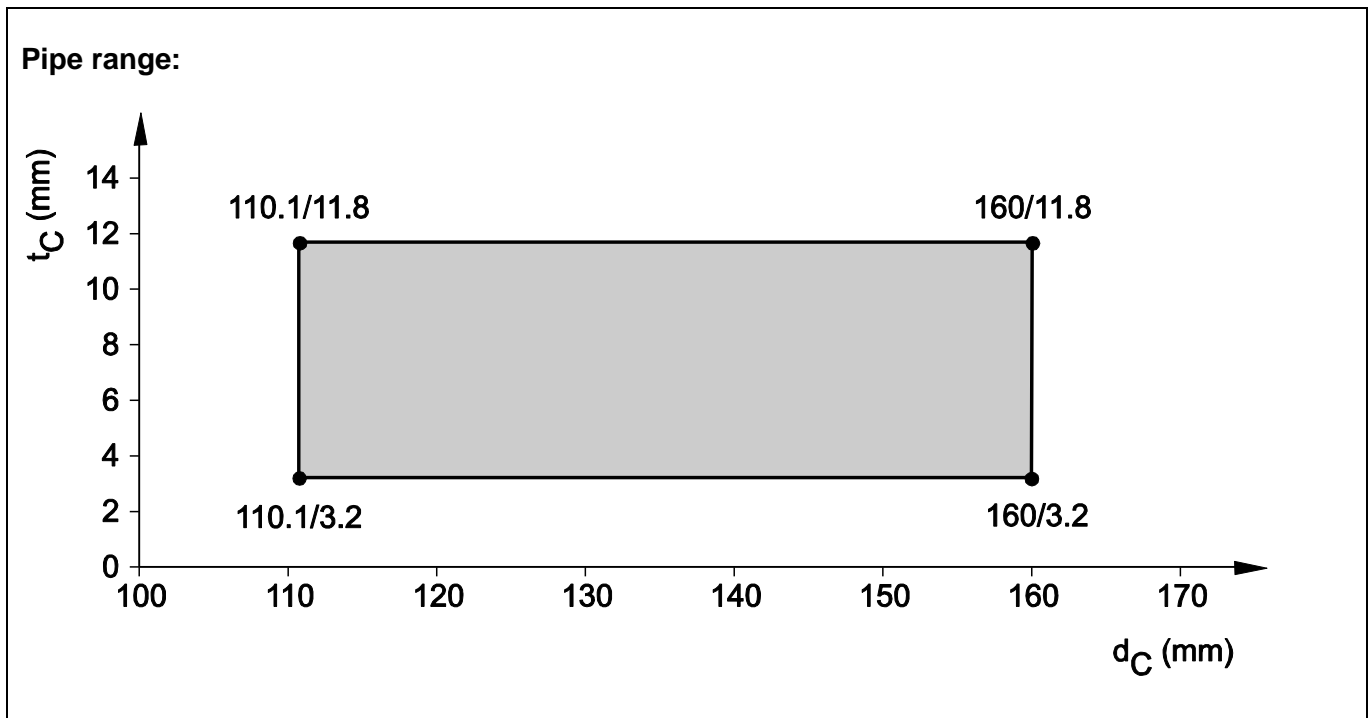

8.5.2.27 **PVC pipes, non-regulated (Friatec Friaphon), in rigid floor ($t_E \geq 150$ mm), pipe group 2, EI 180 - U/U**

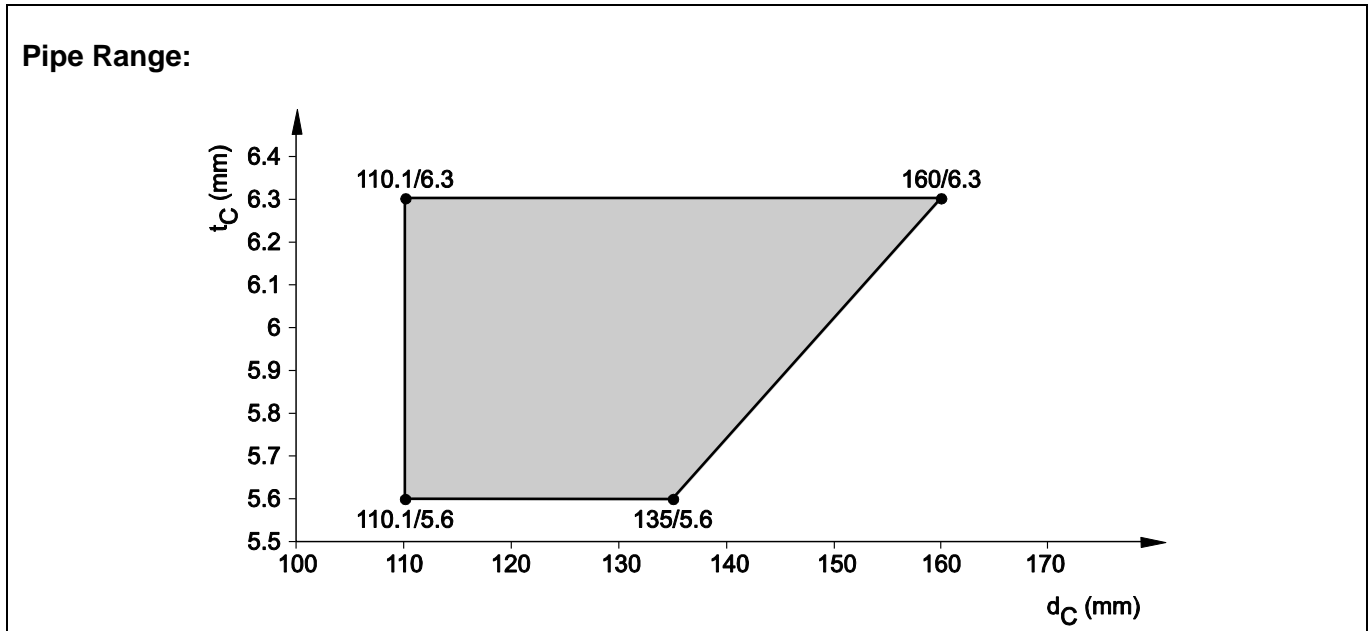

8.5.2.28 **PE-X - pipes acc. EN 15875 (Rehau Rautitan flex), insulated, in rigid floor ($t_E \geq 150$ mm), pipe group 1, EI 120 - U/C**

Situation for EI 120-U/U:

- PE-X acc. EN 15875 (Rehau Rautitan flex)
- Pipe diameter ($16 \text{ mm} \leq d_C \leq 32 \text{ mm}$)
- Pipe wall thickness ($2,2 \text{ mm} \leq t_C \leq 4,4 \text{ mm}$)
- Pipe inclination: 90°

Flexible, elastomeric thermal insulation D_E :

- Type of material: refer to 8.2.12
- Thickness of D_E : ($9 \text{ mm} \leq t_D \leq 25 \text{ mm}$)
- Insulation length: ($L_D \geq 250 \text{ mm}$) on pipes on both sides of the floor
- LS/CS situation

8.5.2.29 **PP-R - pipes acc. EN 15874 (Aquatherm fusiolen = aquatherm green pipe S), insulated, in rigid floor ($t_E \geq 150$ mm), pipe group 1, EI 120 - U/C**

Situation for EI 120-U/U:

- PP-R - pipes acc. EN 15874 Aquatherm fusiolen = aquatherm green pipe S
- Pipe diameter ($16 \text{ mm} \leq d_C \leq 32 \text{ mm}$)
- Pipe wall thickness ($2,2 \text{ mm} \leq t_C \leq 4,4 \text{ mm}$)
- Pipe inclination: 90°

Flexible, elastomeric thermal insulation D_E :

- Type of material: refer to 8.2.12
- Thickness of D_E : ($9 \text{ mm} \leq t_D \leq 25 \text{ mm}$)
- Insulation length: ($L_D \geq 250 \text{ mm}$) on pipes on both sides of the floor
- LS/CS situation

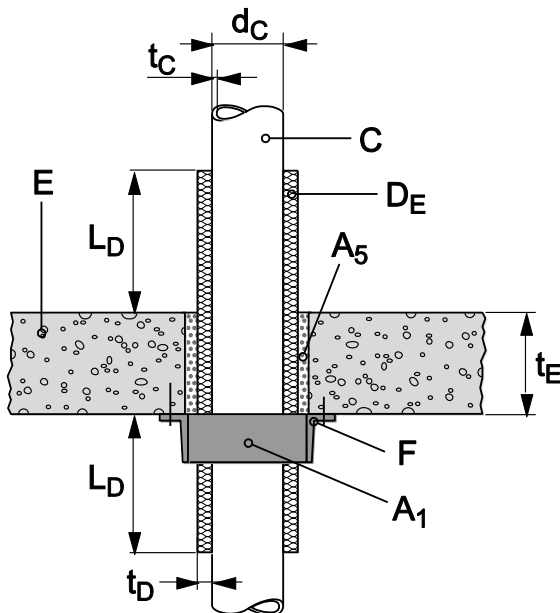

8.5.2.30 **Multiple penetration, thermal insulated, in rigid floor ($t_E \geq 150$ mm), pipe group 1, EI 120 - U/U and U/C**

Situation for multiple pipes for EI 120 – U/C classification:

- One PE pipe acc. EN 1519-1, EN 12666-1, EN 12201-2 (U/U) in zero contact ($0 \text{ mm} \leq s_1 \leq 15 \text{ mm}$) together with
- One or two pipes acc. EN 15874 or EN 15875 (pipe material PP-R or PE-X) (U/C)
- The pipes acc. EN 15874 or EN 15875 are insulated with an elastomeric foamed thermal insulation
- Collar CFS-C EL covers the two or three pipes together within **one** bigger jacket

PE pipe acc. EN 1519-1, EN 12666-1, EN 12201-2 (U/U):

- Pipe outside diameter is ($40 \text{ mm} \leq d_C \leq 90 \text{ mm}$)
- Pipe wall thickness thickness ($t_C = 3,5 \text{ mm}$)
- With or without sound decoupling isolation (for type, thickness and situation refer to 3.1.6)

PP-R or PE-X pipes acc. EN 15874 and EN 15875 (U/C):

- Pipe outside diameter is ($d_c = 40 \text{ mm}$)
- Pipe wall thickness ($t_c = 5,5 \text{ mm}$)
- Type of pipes: Aquatherm fusiolen = aquatherm green pipe S and Rehau Rautitan flex

Elastomeric foamed thermal insulation:

- For material type refer to 8.2.12
- Insulation thickness is ($9 \text{ mm} \leq t_D \leq 32 \text{ mm}$)
- Installation situation is LS and CS
- Minimum insulation length ($L_D \geq 250 \text{ mm}$) on both sides of the floor

Collar fixing:

- For number of hooks refer to 8.2.4 and Tab.3, for fixing the hooks refer to 8.2.3.

View from above:

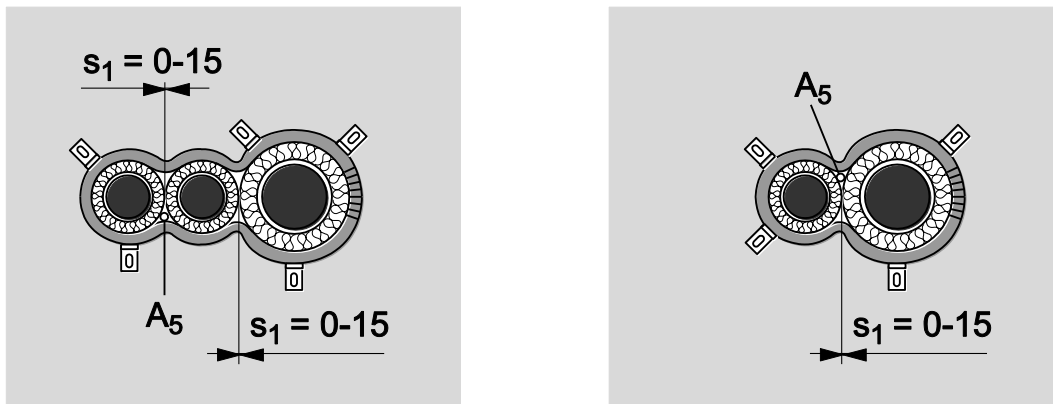

8.5.2.31 Reuse of oddments of CFS-C EL, in rigid floor ($t_E \geq 150 \text{ mm}$), pipe group 1 and 2, EI 120 - U/U

Situation:

- reuse of oddments EI 120 - U/U for pipe group 1
- reuse of oddments EI 120 - U/U for pipe group 2

Pipe material and pipe range:

- For pipe group 1 - refer to 8.5.2.1; 8.5.2.2; 8.5.2.3; 8.5.2.4; 8.5.2.6; 8.5.2.7, 8.5.2.10; 8.5.2.11
 - For pipe group 2 - refer to 8.5.2.14; 8.5.2.15; 8.5.2.19; 8.5.2.21; 8.5.2.22; 8.5.2.24; 8.5.2.26
- Excluded from assessed pipe range (PG1) are pipes with outside nominal diameter ($d_c \geq 110 \text{ mm}$).

Installation details

- For installation details – refer to 8.2.7

Number of hooks:

- For number of hooks – refer to 8.2.4 and 8.2.7

8.5.2.32 Hooks fixed in wet mortar for CFS-C EL, in rigid floor ($t_E \geq 150$ mm), pipe group 1 and 2, EI 120 – U/U

Situation:

- reuse of oddments EI 120 - U/U for pipe group 1
- reuse of oddments EI 120 - U/U for pipe group 2

Pipe material and pipe range:

- For pipe group 1 - refer to 8.5.2.1; 8.5.2.2; 8.5.2.3; 8.5.2.4; 8.5.2.6; 8.5.2.7, 8.5.2.10; 8.5.2.11
 - For pipe group 2 - refer to 8.5.2.14; 8.5.2.15; 8.5.2.19; 8.5.2.21; 8.5.2.22; 8.5.2.24; 8.5.2.26
- Excluded from assessed pipe range (PG1) are pipes with outside nominal diameter ($d_c \geq 110$ mm).

Installation details

- For installation details – refer to 8.2.3

Number of hooks:

- For number of hooks – refer to 8.2.4

8.5.2.33 Pipes in rigid floor ($t_E \geq 150$ mm), pipe group 1, EI 90 - U/U, Inclined Pipes 45°

Situation for EI 90-U/U:

- Pipe inclination ($45^\circ \leq \text{inclination} \leq 90^\circ$)

Pipe range and pipe material:

- refer to 8.5.2.1; 8.5.2.2; 8.5.2.3; 8.5.2.5; 8.5.2.6; 8.5.2.7; 8.5.2.8; 8.5.2.10; 8.5.2.11
- Excluded are only pipes with an outside nominal diameter ($d_c \geq 110$ mm)

Gap size and Gap filling:

- Gap filler: Hilti CFS-S ACR
- Annular Gap: 0 – 15 mm
- Depth t_{A2} to be filled with Hilti CFS-S ACR: ($t_{A2} \geq 25$ mm)
- No backfilling required
- or:
- Gap filler: Hilti CFS-S ACR
- Annular Gap: 0 – 40 mm
- Depth t_{A2} to be filled with Hilti CFS-S ACR: ($t_{A2} \geq 25$ mm) on the upper side of the floor only
- Backfilling required, refer to Annex 2, chapter 7.2
- or:
- Gap filler: cementious Mortar M10 acc. EN 998-2
- Annular Gap: 0 – 40 mm
- Depth to be filled with cementious Mortar M10: to fill over entire floor thickness

Number of hooks:

Pipe outside nominal diameter d_c (mm)	Acoustic Pipe Insulation Thickness t_D (mm) (identical on both sides of the flexible wall/rigid wall)		
	0	4	9
32	3	3	3
50	3	3	3
75	3	4	4
90	4	4	5
110	5	5	5

If pipe insulation thickness is between 0 and 4 mm use the number of hooks indicated for 4 mm.
If pipe insulation thickness is between 4 and 9 mm use the number of hooks indicated for 9 mm.

8.5.2.34 All PP pipes non-regulated, in rigid floor ($t_E \geq 150$ mm), pipe group 1, EI 120 - U/U, elbow pipes 87°

Situation for EI 120-U/U:

- Elbow connector (87°) for non-regulated PP pipes
- Elbow connector (87°) installed inside the wall or partly inside the wall, sealed with Collar CFS-C EL
- On one side the pipe may run parallel to the floor having a zero distance to wall ($s_3 \geq 0$ mm)

Pipe range and pipe material:

- For pipe range - refer to 8.5.2.6
- For pipe material - refer to 8.2.15

Gap size and Gap filling:

- Gap filler: Hilti CFS-S ACR
- Annular gap: 0 – 15 mm
- Depth t_{A2} to be filled with Hilti CFS-S ACR: ($t_{A2} \geq 25$ mm)
- No backfilling required
or:
- Gap filler: Hilti CFS-S ACR
- Annular gap: 0 – 40 mm
- Depth t_{A2} to be filled with Hilti CFS-S ACR: ($t_{A2} \geq 25$ mm) on the upper side of the floor only
- Backfilling required, refer to Annex 2, chapter 7.2
or:
- Gap filler: cementious Mortar M10 acc. EN 998-2
- Annular gap: 0 – 40 mm
- Depth to be filled with cementious Mortar M10: to fill over entire floor thickness

Collar fixing:

- Refer to 8.2.3

Number of hooks:

Pipe outside nominal diameter d_c (mm)	Acoustic Pipe Insulation Thickness t_D (mm) (no elbow side - vertical running pipe / elbow side - horizontal running pipe)		
	0	4	9
32	2 / 2	2 / 2	2 / 2
50	2 / 2	2 / 2	2 / 3
75	3 / 3	3 / 3	3 / 3
90	3 / 3	3 / 3	3 / 3
110	3 / 4	3 / 4	3 / 4

If pipe insulation thickness is between 0 and 4 mm use the number of hooks indicated for 4 mm.
 If pipe insulation thickness is between 4 and 9 mm use the number of hooks indicated for 9 mm.

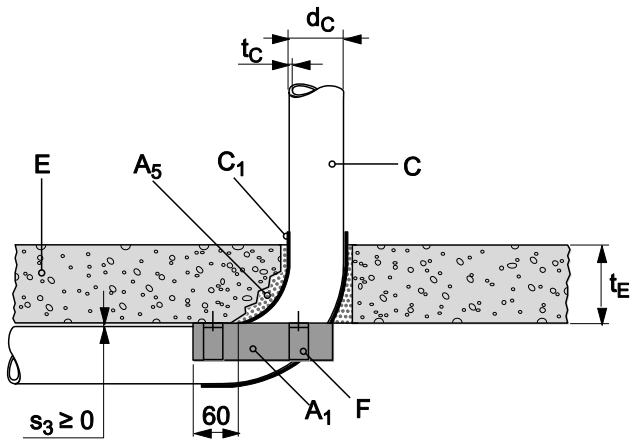

8.5.2.35 All PP pipes non-regulated, in rigid floor ($t_E \geq 150$ mm), pipe group 1, EI 120 - U/U, elbow pipes 2 x 45°

Situation for EI 120-U/U:

- Elbow connector (2 pieces each of 45°) for non-regulated PP pipes
- Elbow installed inside the wall or partly inside the wall, sealed with Collar CFS-C EL
- On one side the pipe may run parallel to the floor having a zero distance to floor ($s_3 \geq 0$ mm)

Pipe range and material:

- For pipe range – refer to 8.5.2.6
- For pipe material – refer to 8.2.15

Gap size and Gap filling:

- Gap filler: Hilti CFS-S ACR
- Annular gap: 0 – 15 mm
- Depth t_{A2} to be filled with Hilti CFS-S ACR: ($t_{A2} \geq 25$ mm)
- No backfilling required
or:
- Gap filler: Hilti CFS-S ACR
- Annular gap: 0 – 40 mm
- Depth t_{A2} to be filled with Hilti CFS-S ACR: ($t_{A2} \geq 25$ mm) on the upper side of the floor only
- Backfilling required, refer to Annex 2, chapter 7.2
or:
- Gap filler: cementious Mortar M10 acc. EN 998-2
- Annular gap: 0 – 40 mm
- Depth to be filled with cementious Mortar M10: to fill over entire floor thickness

Number of hooks:

Pipe outside nominal diameter d_c (mm)	Acoustic Pipe Insulation Thickness t_D (mm) (no elbow side - horizontal running pipe / elbow side - vertical running pipe)		
	0	4	9
32	2 / 2	2 / 2	2 / 2
50	2 / 2	2 / 2	2 / 3
75	3 / 3	3 / 3	3 / 3
90	3 / 3	3 / 3	3 / 3
110	3 / 4	3 / 4	3 / 4

If pipe insulation thickness is between 0 and 4 mm use the number of hooks indicated for 4 mm.
 If pipe insulation thickness is between 4 and 9 mm use the number of hooks indicated for 9 mm.

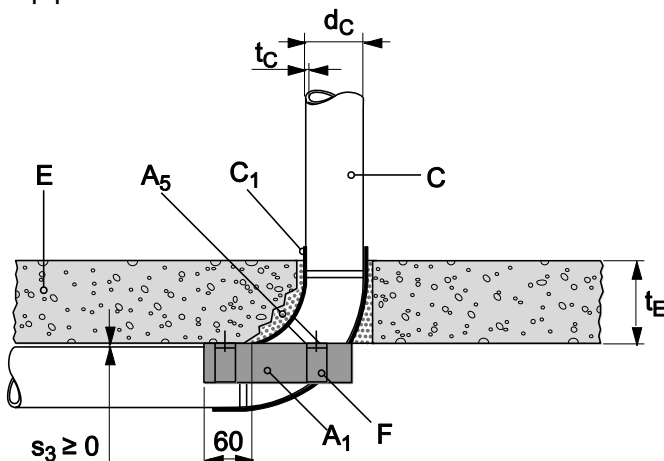

8.5.2.36 Pipes in rigid floor ($t_E \geq 150$ mm), pipe group 1, EI 90 - U/U, pipe in corner application – zero distance to two walls

Situation for EI 90 – U/U:

- Pipes directly mounted in the corner
- Zero distance ($s_3 \geq 0$ mm) pipe to two walls at same time
- Collar CFS-C EL cannot completely cover the circumference of sealed pipe

Pipe range:

- For pipe material - refer to 8.5.2.1; 8.5.2.2; 8.5.2.3; 8.5.2.5; 8.5.2.6; 8.5.2.7; 8.5.2.8; 8.5.2.10; 8.5.2.11
- For pipe dimension - refer to 8.5.2.1; 8.5.2.2; 8.5.2.3; 8.5.2.5; 8.5.2.6; 8.5.2.7; 8.5.2.8; 8.5.2.10; 8.5.2.11

Excluded are pipes with outside nominal diameter ($d_C \geq 110$ mm)

Gap size and Gap filler:

With CFS-S ACR:

- Gap size is 0 to 15 mm
- Gap filler is CFS-S ACR
- Installation depth: ($t_{A3} \geq 25$ mm) on each side of the floor
- No backfilling
- or:
- Gap size is 0 to 40 mm
- Gap filler is CFS-S ACR
- Installation depth: ($t_{A3} \geq 25$ mm) on the upper side of the floor only
- Backfilling with mineral wool, refer to Annex 2, chapter 7.2

With cementitious mortar:

- Gap size is 0 to 40 mm
- Gap filler is mortar group M10 acc. EN 998-2
- Installation depth: over the entire thickness of the floor

Number of hooks:

- For number of hooks – refer to 8.2.4

View to soffit

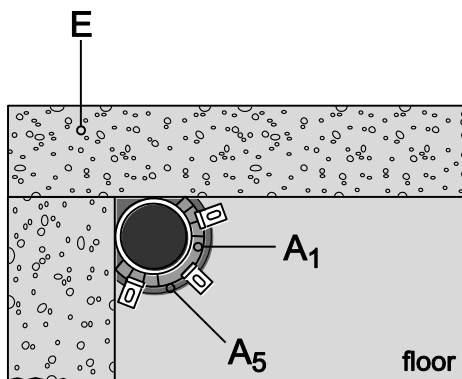

8.5.2.37 Pipes in rigid floor ($t_E \geq 150$ mm), pipe group 1, EI 120 - U/U, pipe on wall application – zero distance to one wall when penetrating the floor

Situation for EI 120 – U/U:

- Pipes directly mounted on the wall
- Zero distance ($s_3 \geq 0$ mm) pipe to one wall
- Collar CFS-C EL cannot completely cover the circumference of sealed pipe

Pipe range:

- For pipe material – refer to 8.5.2.1; 8.5.2.2; 8.5.2.3; 8.5.2.4; 8.5.2.6; 8.5.2.7; 8.5.2.10; 8.5.2.11
- For pipe dimension – refer to 8.5.2.1; 8.5.2.2; 8.5.2.3; 8.5.2.4; 8.5.2.6; 8.5.2.7; 8.5.2.10; 8.5.2.11

Excluded are pipes with outside nominal diameter ($d_c \geq 110$ mm)

Gap size and Gap filler:

With CFS-S ACR:

- Gap size is 0 to 15 mm
- Gap filler is CFS-S ACR
- Installation depth: ($t_{A3} \geq 25$ mm) on each side of the wall
- No backfilling
- or:
- Gap size is 0 to 40 mm
- Gap filler is CFS-S ACR
- Installation depth: ($t_{A3} \geq 25$ mm) on the upper side of the floor only
- Backfilling with mineral wool, refer to Annex 2, chapter 7.2

With cementious mortar:

- Gap size is 0 to 40 mm
- Gap filler is mortar group M10 acc. EN 998-2
- Installation depth: over the entire floor thickness

Number of hooks:

- For number of hooks – refer to 8.2.4

View to soffit

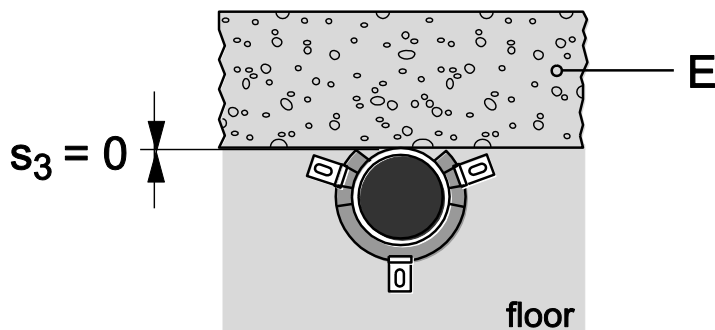

8.5.2.38 All PP pipes non-regulated, named in 8.5.2.6; in rigid floor ($t_E \geq 150$ mm), pipe group 1, EI 120 - U/U, pipe coupling

Situation for EI 120 – U/U:

- Pipe coupling may be within the floor or directly below/above the floor
- Pipe coupling covered by CFS-C EL collar

Pipe range:

- For pipe material - refer to 8.2.15
- For pipe dimension - refer to 8.5.2.6

Gap size and Gap filler:

With CFS-S ACR:

- Gap size is 0 to 15 mm
- Gap filler is CFS-S ACR
- Installation depth: ($t_{A3} \geq 25$ mm) on each side of the floor
- No backfilling
- or:
- Gap size is 0 to 40 mm
- Gap filler is CFS-S ACR
- Installation depth: ($t_{A3} \geq 25$ mm) on the upper side of the floor only
- Backfilling with mineral wool, refer to Annex 2, chapter 7.2

With cementious mortar:

- Gap size is 0 to 40 mm
- Gap filler is mortar group M10 acc. EN 998-2
- Installation depth: over the entire floor thickness

Number of hooks:

Pipe outside nominal diameter d_c (mm)	Acoustic Pipe Insulation Thickness t_D (mm)		
	(incoming pipe / outgoing pipe)		
	0	4	9
32	2 / 2	2 / 2	2 / 2
50	2 / 2	2 / 2	2 / 3
75	3 / 3	3 / 3	3 / 3
90	3 / 3	3 / 3	3 / 3
110	3 / 4	3 / 4	3 / 4

If pipe insulation thickness is between 0 and 4 mm use the number of hooks indicated for 4 mm.
 If pipe insulation thickness is between 4 and 9 mm use the number of hooks indicated for 9 mm.

8.5.2.39 Pipes in rigid floor ($t_E \geq 150$ mm), pipe group 1, EI 120 - U/U, zero distance collar to collar application (in line)

Situation for EI 120-U/U (refer to 8.2.9):

- Zero distance between two CFS-C EL collars, sealing two plastic pipes ($s_1 \geq 0$ mm)
 - Type of pipes: refer to 8.5.2.1; 8.5.2.2; 8.5.2.3; 8.5.2.4; 8.5.2.6; 8.5.2.7; 8.5.2.10; 8.5.2.11
 - Range of pipes: refer to 8.5.2.1; 8.5.2.2; 8.5.2.3; 8.5.2.4; 8.5.2.6; 8.5.2.7; 8.5.2.10; 8.5.2.11
- Excluded are only pipes with outside nominal diameter ($d_C \geq 110$ mm)
- Pipes have to be group in line
 - Number of pipes in line is unlimited

8.5.2.40 Pipes in rigid floor ($t_E \geq 150$ mm), pipe group 2, EI 120 - U/U, zero distance collar to collar application (in line)

Situation for EI 120 - U/U (refer to 8.2.9):

- Zero distance between two CFS-C EL collars, sealing two plastic pipes ($s_1 \geq 0$ mm)
- Type of pipes: refer to 8.5.2.14; 8.5.2.15; 8.5.2.19; 8.5.2.21; 8.5.2.22; 8.5.2.24; 8.5.2.26
- Range of pipes: refer to 8.5.2.14; 8.5.2.15; 8.5.2.19; 8.5.2.21; 8.5.2.22; 8.5.2.24; 8.5.2.26
- Pipes have to be group in line
- Number of pipes in line is unlimited

8.5.2.41 Zero distance CFS-C EL to mineralwool insulated pipes

8.5.2.41.1 Pipes in rigid floor ($t_E \geq 150$ mm), pipe group 1, EI 120 - U/U, zero distance collar CFS-C EL to mineral wool thermal insulation on metal pipes

Situation for EI 120 - U/U:

- Collar CFS-C EL on plastic pipe in direct contact to mineral wool insulation ($s_1 \geq 0$ mm) on metal pipes
- Type of pipes: refer to 8.5.2.1; 8.5.2.2; 8.5.2.3; 8.5.2.4; 8.5.2.6; 8.5.2.7; 8.5.2.10; 8.5.2.11
- Range of pipes: refer to 8.5.2.1; 8.5.2.2; 8.5.2.3; 8.5.2.4; 8.5.2.6; 8.5.2.7; 8.5.2.10; 8.5.2.11
Excluded are only pipes with an outside nominal diameter ($d_C \geq 110$ mm).
- Used type of Insulation: refer to 8.2.10.1

Pipes diameter ($d_M \leq 42$ mm):

- Insulation thickness ($t_D \geq 19$ mm) within the flexible wall ($t_E = L_D$)
- Insulation thickness ($t_D \geq 20$ mm) on metal pipes on both sides of the wall
- Insulation length $L_D \geq 1000$ mm on both sides of the wall
- LS situation

Pipes diameter (42 mm $< d_M \leq 89$ mm):

- insulation thickness for mineral wool on metal pipes outside the floor: ($t_D \geq 30$ mm)
- insulation length below and above the floor: $L_D \geq 1000$ mm
- insulation thickness on metal pipe within the floor ($t_D \geq 20$ mm), $t_E = L_D$
- LS situation

Metal pipes, insulated by named above types of mineral wool products:

- pipe diameter ($d_M \leq 89$ mm)
- pipe wall thickness of ($1,2$ mm $\leq t_M \leq 14,2$ mm)
- Covered material types – refer to 8.2.11

Gap size and Gap filler:

- Gap filler: Hilti CFS-S ACR
- Annular Gap: 0 to 15 mm
- Depth t_{A2} to be filled with Hilti CFS-S ACR: ($t_{A2} \geq 25$ mm)
- No backfilling required
or:
- Gap filler is CFS-S ACR
- Annular Gap: 0 to 40 mm
- Installation depth: ($t_{A2} \geq 25$ mm) on the upper side of the floor only
- Backfilling with mineral wool, refer to Annex 2, chapter 7.2.
or:
- Gap filler: cementious Mortar M10 acc. EN 998-2
- Annular Gap: 0 to 40 mm
- Depth to be filled with cementious Mortar M10: to fill over entire floor thickness

8.5.2.41.2 Pipes in rigid floor ($t_E \geq 150$ mm), pipe group 1, EI 120 - U/U, zero distance collar CFS-C EL to mineral wool thermal insulation on metal pipes

Situation for EI 120 - U/U:

- Collar CFS-C EL on plastic pipe in direct contact to mineral wool insulation ($s_1 \geq 0$ mm) on metal pipes
- Type of pipes: refer to 8.5.2.1; 8.5.2.2; 8.5.2.3; 8.5.2.4; 8.5.2.6; 8.5.2.7; 8.5.2.10; 8.5.2.11
- Range of pipes: refer to 8.5.2.1; 8.5.2.2; 8.5.2.3; 8.5.2.4; 8.5.2.6; 8.5.2.7; 8.5.2.10; 8.5.2.11
Excluded are pipes with an outside nominal diameter ($d_C \geq 110$ mm)
- Used type of Insulation: refer to 8.2.10.1

Pipes diameter ($d_M \leq 42$ mm):

- Insulation thickness ($t_D \geq 19$ mm) within the flexible wall ($t_E = L_D$)
- Insulation thickness ($t_D \geq 20$ mm) on metal pipes on both sides of the wall
- Insulation length $L_D \geq 1000$ mm on both sides of the wall
- LS situation

Pipes diameter (42 mm $< d_M \leq 114,3$ mm):

- insulation thickness for mineral wool on metal pipes outside the floor: ($t_D \geq 30$ mm)
- insulation length below and above the floor: $L_D \geq 1000$ mm
- insulation thickness on metal pipe within the floor ($t_D \geq 30$ mm), $t_E = L_D$
- LS situation

Metal pipes, insulated by named above types of mineral wool products:

- pipe diameter ($d_M \leq 114,3$ mm)
- pipe wall thickness of ($1,2$ mm $\leq t_M \leq 14,2$ mm)
- Covered material types– refer to 8.2.11, excluded material is copper

Gap size and Gap filler:

- Gap filler: Hilti CFS-S ACR
- Annular Gap: 0 - 15 mm
- Depth t_{A2} to be filled with Hilti CFS-S ACR: ($t_{A2} \geq 25$ mm)
- No backfilling required
or:
- Gap filler is CFS-S ACR
- Annular Gap: 0 - 40 mm
- Installation depth: ($t_{A2} \geq 25$ mm) on the upper side of the floor only
- Backfilling with mineral wool, refer to Annex 2, chapter 7.2.
or:
- Gap filler: cementious Mortar M10 acc. EN 998-2
- Annular Gap: 0 - 40 mm
- Depth to be filled with cementious Mortar M10: to fill over entire floor thickness

8.5.2.41.3 Pipes in rigid floor ($t_E \geq 150$ mm), pipe group 1, EI 120 - U/U, zero distance collar CFS-C EL to mineral wool thermal insulation on aluminum composite pipes

Situation for EI 120 - U/U:

- Collar CFS-C EL on plastic pipe in direct contact to mineral wool insulation ($s_1 \geq 0$ mm) on aluminum
 - Type of pipes: refer to 8.5.2.1; 8.5.2.2; 8.5.2.3; 8.5.2.4; 8.5.2.6; 8.5.2.7; 8.5.2.10; 8.5.2.11
 - Range of pipes: refer to 8.5.2.1; 8.5.2.2; 8.5.2.3; 8.5.2.4; 8.5.2.6; 8.5.2.7; 8.5.2.10; 8.5.2.11
- Excluded are only pipes with an outside nominal diameter ($d_c \geq 110$ mm).

Mineral wool based thermal insulation

- Used type of Insulation: refer to 8.2.10.2
- insulation thickness: $t_D \geq 20$ mm and ≤ 60 mm
- insulation length: $L_D \geq 1000$ mm
- LS situation

Aluminum composite pipes, insulated by named above types of mineral wool products:

- See table below

Gap size and Gap filler:

- Gap filler: Hilti CFS-S ACR
- Annular Gap: 0 - 15 mm
- Depth t_{A2} to be filled with Hilti CFS-S ACR: ($t_{A2} \geq 25$ mm)
- No backfilling required
- or:
- Gap filler is CFS-S ACR
- Annular Gap: 0 - 40 mm
- Installation depth: ($t_{A2} \geq 25$ mm) on the upper side of the floor only
- Backfilling with mineral wool, refer to Annex 2, chapter 7.2
- or:
- Gap filler: cementious Mortar M10 acc. EN 998-2
- Annular Gap: 0 - 40 mm
- Depth to be filled with cementious Mortar M10: to fill over entire floor thickness

Pipe Ø (mm)	Wall thickness (mm)	Pipe Insulation		
		Type	Thickness (mm)	Configuration (---)
Geberit Mepla – material: PE-Xb/Al/PE-Xb				
16 - 63	2,25 - 4,5	mineralwool	20 - 60	LS
Kekelit Kelox – material: PE-RT/Al/PE-RT				
16 - 63	2,0 - 6,0	mineralwool	20 - 60	LS
Rehau Rautitan Flex – material: PE-Xa – standard: EN 151875				
16 - 63	2,2 - 8,6	mineralwool	20 - 60	LS
TECEflex Verbundrohr – material: PE-Xc/Al/PE				
16 - 63	2,75 - 6,0	mineralwool	20 - 60	LS

Uponor Unipipe MLC – material: PE-RT/Al/PE-RT				
16 - 63	2,0 - 6,0	mineralwool	20 - 60	LS
Uponor Unipipe Plus – material: PE-RT/Al/PE-RT				
16 - 32	2,0 - 3,0	mineralwool	20 - 60	LS
Viega Raxofix – material: PE-Xc/Al/PE-Xc				
16 - 63	2,2 - 4,5	mineralwool	20 - 60	LS
Wavin Tigris – material: PE-Xc/Al/PE				
16 - 63	2,0 - 6,0	mineralwool	20 - 60	LS

electronic copy electronic copy electronic copy electronic copy electronic copy electronic copy electronic copy electronic copy electronic copy electronic copy

8.5.2.42 Zero distance CFS-C EL to combustible insulated pipes

8.5.2.42.1 Pipes in rigid floor ($t_E \geq 150$ mm), pipe group 1, EI 90 - U/U, zero distance collar CFS-C EL to Hilti CFS-B, used to seal an elastomeric thermal insulation on metal pipes

Situation for EI 90 - U/U:

- Zero distance between CFS-C EL collar and CFS-B, wrapped around an elastomeric foamed thermal insulation on metallic pipe ($s_1 \geq 0$ mm)
- Type of pipes: refer to 8.5.2.1; 8.5.2.2; 8.5.2.3; 8.5.2.5; 8.5.2.6; 8.5.2.7; 8.5.2.8; 8.5.2.10; 8.5.2.11
- Range of pipes: refer to 8.5.2.1; 8.5.2.2; 8.5.2.3; 8.5.2.5; 8.5.2.6; 8.5.2.7; 8.5.2.8; 8.5.2.10; 8.5.2.11

Excluded are pipes with outside nominal diameter ($d_C \geq 110$ mm)

Flexible, elastomeric thermal insulation D_E :

- Type of material: refer to 8.2.12
- Thickness of D_E : ($9 \text{ mm} \leq t_D \leq 35 \text{ mm}$)
- Insulation length: ($L_D \geq 250$ mm) on pipes on both sides of the floor
- CS situation

Metal pipes:

- Pipe diameter ($15 \text{ mm} \leq t_D \leq 42 \text{ mm}$)
- Pipe wall thickness of ($1,0 \text{ mm} \leq t_M \leq 14,2 \text{ mm}$)
- Covered material types for metal pipes – refer to 8.2.11

Gap size and gap filling:

- Gap filler: Hilti CFS-S ACR
- Annular gap: 0 - 15 mm
- Depth t_{A2} to be filled with Hilti CFS-S ACR: ($t_{A2} \geq 25$ mm)
- No backfilling required
or:
- Gap filler: Hilti CFS-S ACR
- Annular gap: 0 - 40 mm
- Depth t_{A2} to be filled with Hilti CFS-S ACR: ($t_{A2} \geq 25$ mm) on the upper side of the floor only
- Back filled with mineral wool, refer to Annex 2, chapter 7.2.
or:
- Gap filler: cementious Mortar M10 acc. EN 998-2
- Annular gap: 0 - 40 mm
- Depth to be filled with cementious Mortar M10: to fill over entire floor thickness

**8.5.2.42.2 Pipes in rigid floor ($t_E \geq 150$ mm), pipe group 1, EI 90 - U/U, zero distance collar
CFS-C EL to Hilti CFS-B, used to seal an elastomeric thermal insulation on metal pipes**

Situation for EI 90 - U/U (refer to 8.2.10.3):

- Zero distance between CFS-C EL collar and CFS-B, wrapped around an elastomeric foamed thermal insulation on metallic pipe ($s_1 \geq 0$ mm)
- Type of pipes: refer to 8.5.2.1; 8.5.2.2; 8.5.2.3; 8.5.2.5; 8.5.2.6; 8.5.2.7; 8.5.2.8; 8.5.2.10; 8.5.2.11
- Range of pipes: refer to 8.5.2.1; 8.5.2.2; 8.5.2.3; 8.5.2.5; 8.5.2.6; 8.5.2.7; 8.5.2.8; 8.5.2.10; 8.5.2.11

Excluded are pipes with outside nominal diameter ($d_C \geq 110$ mm)

Flexible, elastomeric thermal insulation D_E :

- Type of material: refer to 8.2.12
- Thickness of D_E : ($9,5 \text{ mm} \leq t_D \leq 40,5 \text{ mm}$)
- Insulation length: ($L_D \geq 250$ mm) on pipes on both sides of the floor
- CS situation

Metal pipes:

- Pipe diameter ($15 \text{ mm} \leq d_M \leq 76 \text{ mm}$)
- Pipe wall thickness of ($1,0 \text{ mm} \leq t_M \leq 14,2 \text{ mm}$)
- Covered material types for metal pipes – refer to 8.2.11, excluded material is copper

Gap size and gap filling:

- Gap filler: Hilti CFS-S ACR
- Annular gap: 0 - 15 mm
- Depth t_{A2} to be filled with Hilti CFS-S ACR: ($t_{A2} \geq 25$ mm)
- No backfilling required
or:
- Gap filler: Hilti CFS-S ACR
- Annular gap: 0 - 40 mm
- Depth t_{A2} to be filled with Hilti CFS-S ACR: ($t_{A2} \geq 25$ mm) on the upper side of the floor only
- Back filled with mineral wool, refer to Annex 2, chapter 7.2.
or:
- Gap filler: cementious Mortar M10 acc. EN 998-2
- Annular gap: 0 - 40 mm
- Depth to be filled with cementious Mortar M10: to fill over entire floor thickness

8.5.2.42.3 Pipes in rigid floor ($t_E \geq 150$ mm), pipe group 1, EI 90 - U/U, zero distance collar CFS-C EL to Hilti CFS-B, used to seal an elastomeric thermal insulation on aluminum composite und PP-R pipes

Situation for EI 90 - U/U (refer to 8.2.10.3):

- Zero distance between CFS-C EL collar and CFS-B, wrapped around an elastomeric foamed thermal insulation on aluminum composite und PP-R pipes ($s_1 \geq 0$ mm)
- Type of pipes: refer to 8.5.2.1; 8.5.2.2; 8.5.2.3; 8.5.2.5; 8.5.2.6; 8.5.2.7; 8.5.2.8; 8.5.2.10; 8.5.2.11
- Range of pipes: refer to 8.5.2.1; 8.5.2.2; 8.5.2.3; 8.5.2.5; 8.5.2.6; 8.5.2.7; 8.5.2.8; 8.5.2.10; 8.5.2.11

Excluded are only pipes with outside nominal diameter ($d_C \geq 110$ mm)

Pipes to CFS-C EL:

- See table below

Flexible, elastomeric thermal insulation D_E :

- Type of material: refer to 8.2.12
- Thickness of D_E : see table below
- Insulation length: CS situation

Gap size and gap filling:

- Gap filler: Hilti CFS-S ACR
- Annular gap: 0 - 15 mm
- Depth t_{A2} to be filled with Hilti CFS-S ACR: ($t_{A2} \geq 25$ mm)
- No backfilling required
- or:
- Gap filler: Hilti CFS-S ACR
- Annular gap: 0 - 40 mm
- Depth t_{A2} to be filled with Hilti CFS-S ACR: ($t_{A2} \geq 25$ mm) on the upper side of the floor only
- Back filled with mineral wool, refer to Annex 2, chapter 7.2
- or:
- Gap filler: cementious Mortar M10 acc. EN 998-2
- Annular gap: 0 - 40 mm
- Depth to be filled with cementious Mortar M10: to fill over entire floor thickness

Aluminum composite pipes and PP-R pipes EI120 U/C

Pipe Ø (mm)	Wall thickness (mm)	Pipe Insulation		
		Type	Thickness (mm)	Configuration (---)
Aquatherm green – material: PP-R – standard: EN 15874, DIN 8077/78				
20 - 110	1,9 - 10,0	elastomeric	8,0 - 40,5	CS
Fränkische Rohrwerke - Alpex F50 Profi – material: PE-X/Al/PE-X				
16 - 40	2,0 - 3,5	elastomeric	8,0 - 36,5	CS
63 - 75	4,5 - 5	elastomeric	39,0 - 40,5	CS

Geberit Mepla – material: PE-Xb/Al/PE-Xb				
16 - 63	2,25 - 4,5	elastomeric	9,0 - 39	CS
Georg Fischer - Sanipex – material: PE-Xc/Al/PE-Xb				
16 - 63	2,25 - 4,5	elastomeric	9,0 - 39	CS
Kekelit Kelox – material: PE-RT/Al/PE-RT				
16 - 75	2,0 - 7,0	elastomeric	8,0 - 40,5	CS
Kekelit Ketrax – material: Cryolen Polyolefinblend (POB) – standard: EN 15847				
20 - 75	1,9 - 6,8	elastomeric	8,0 - 40,5	CS
Polo-Polymutan – material: PP-R 80 – standard: DIN 8077/78				
20 - 75	1,9/6,8 - 12,5	elastomeric	8,0 - 40,5	CS
Polo-Polymutan ML5– material: PP-R				
20 - 75	2,8 - 10,8	elastomeric	8,0 - 40,5	CS
Prineto Stabil Rohr – material: PE-Xb/Al/PE-HD				
17 - 63	2,8 - 6,0	elastomeric	8,0 - 39,0	CS
Rehau Rautitan Flex – material: PE-Xa – standard: EN 151875				
16 - 63	2,2 - 8,6	elastomeric	8,0 - 39	CS
TECEflex Verbundrohr – material: PE-Xc/Al/PE				
16 - 63	2,2 - 6,0	elastomeric	9,0 - 39	CS
Uponor Unipipe MLC – material: PE-RT/Al/PE-RT				
16 - 63	2,0 - 6,0	elastomeric	8,0 - 35	CS
Uponor Unipipe Plus – material: PE-RT/Al/PE-RT				
16 - 32	2,0 - 3,0	elastomeric	8,0 – 35,0	CS
Viega - SANIFIX Fosta-Rohr – material: PE-Xc/Al/PE-Xc				
16 - 63	2,2 – 4,5	elastomeric	8,0 – 39,0	CS
Viega Raxofix – material: PE-Xc/Al/PE-Xc				
16 - 63	2,2 – 3,2	elastomeric	8,0 - 39,0	CS
Wavin TS – material: PE 100				
50 - 75	4,6 – 6,8	elastomeric	9,0 – 40,5	CS

8.5.2.42.4 Pipes in rigid floor ($t_E \geq 150$ mm), pipe group 1, EI 90 - U/U, zero distance collar to Hilti CFS-B, wrapped around PE foamed insulation or PE protection tube on aluminum composite pipes

Situation for EI 90 - U/U:

- Zero distance between CFS-C EL collar and CFS-B, wrapped around PE foamed insulation or PE protection tube on aluminum composite pipes ($s_1 \geq 0$ mm)
- Type of pipes: refer to 8.5.2.1; 8.5.2.2; 8.5.2.3; 8.5.2.5; 8.5.2.6; 8.5.2.7; 8.5.2.8; 8.5.2.10; 8.5.2.11
- Range of pipes: refer to 8.5.2.1; 8.5.2.2; 8.5.2.3; 8.5.2.5; 8.5.2.6; 8.5.2.7; 8.5.2.8; 8.5.2.10; 8.5.2.11

Excluded are pipes with outside nominal diameter ($d_c \geq 110$ mm)

Pipes to CFS-C EL:

- See table below

PE-Insulation:

- Material types: foamed polyethylene insulation
- Assessed brands: as preinstalled from the pipe supplier or refer to 8.2.13

Gap size and gap filling:

- Gap filler: Hilti CFS-S ACR
- Annular gap: 0 - 15 mm
- Depth t_{A2} to be filled with Hilti CFS-S ACR: ($t_{A2} \geq 25$ mm)
- No backfilling required
or:
- Gap filler: Hilti CFS-S ACR
- Annular gap: 0 - 40 mm
- Depth t_{A2} to be filled with Hilti CFS-S ACR: ($t_{A2} \geq 25$ mm) on the upper side of the floor only
- Back filled with mineral wool, refer to Annex 2, chapter 7.2.
or:
- Gap filler: cementious Mortar M10 acc. EN 998-2
- Annular gap: 0 - 40 mm
- Depth to be filled with cementious Mortar M10: to fill over entire floor thickness

PE foamed insulation or PE protection tube on aluminium composite EI120 U/C

Pipe Ø (mm)	Wall thickness (mm)	Pipe Insulation		
		Type	Thickness (mm)	Configuration (mm)
Geberit Mepla – material: PE-Xb/Al/PE-Xb				
16 - 26	2,2 - 3,0	PE-foam	6,0 – 13,0	CS
Kekelit Kelox – material: PE-RT/Al/PE-RT				
14 - 32	2,0 - 3,0	PE-foam	4,0 – 9,0	CS
16 - 20	2,0 - 2,25	PE-HD tube		LS ≥ 250
16 - 20	2,0 - 2,25	PE Foam + PE-HD tube	4,0	CS
Uponor Unipipe MLC – material: PE-RT/Al/PE-RT				
16 - 20	2,0 - 2,25	PE-HD tube		LS ≥ 250
Uponor Unipipe Plus – material: PE-RT/Al/PE-RT				
16 - 25	2,0 - 2,5	PE foam	4,0 -10,0	CS

electronic copy

8.5.2.43 Pipes in rigid floor ($t_E \geq 150$ mm), pipe group 1, EI 90 - U/U, pipes installed in mineral wool board CFS-CT B and sealed with CFS-C EL Collar

Situation for EI 90 - U/U (refer to 8.2.14):

- Plastic pipes, penetrating a wall seal made off mineral wool board, could be sealed with CFS-C EL
- Type of pipes: refer to 8.5.2.1; 8.5.2.2; 8.5.2.3; 8.5.2.5; 8.5.2.6; 8.5.2.7; 8.5.2.8; 8.5.2.10; 8.5.2.11
- Range of pipes: refer to 8.5.2.1; 8.5.2.2; 8.5.2.3; 8.5.2.5; 8.5.2.6; 8.5.2.7; 8.5.2.8; 8.5.2.10; 8.5.2.11

Excluded are only pipes with outside nominal diameter ($d_C \geq 110$ mm)

- Distance between the pipes penetrating the board is ($s_1 \geq 100$ mm)
- Pipes have to be grouped in line only
- The number of penetrating pipes in line is not limited.
- Pipes are allowed with zero distance to building element ($s_3 \geq 0$ mm)
- Gap seal around the board to building element is CFS-S ACR
- Gap seal around the pipes to board or building element is CFS-S ACR
- For installation refer to 8.2.14

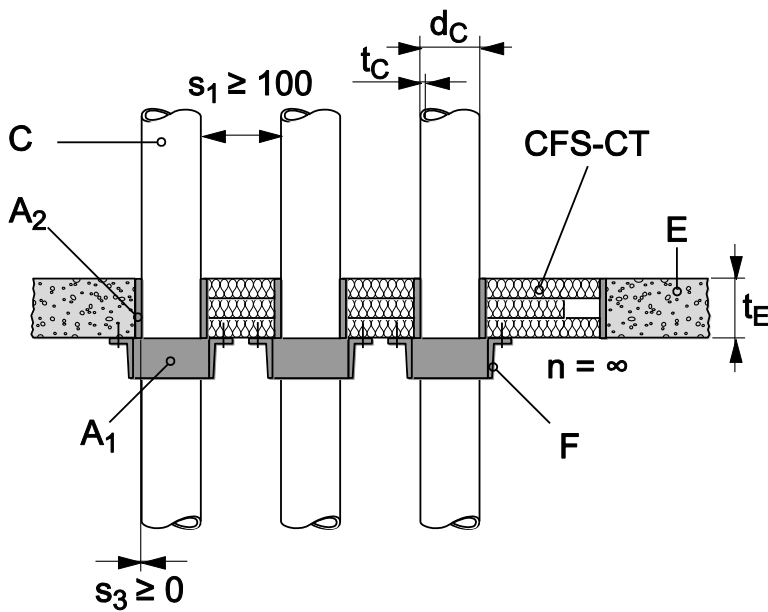

8.5.2.44 Roof drainage covered with foamed elastomeric thermal insulation in rigid floor ($t_E \geq 150$ mm), pipe group 1 and 2, EI 120 -180 U/U

Situation for roof drainage for EI 120 -180 U/U:

- One pipe (U/U) insulated with elastomeric foamed insulation, sealed with CFS-C EL

Pipe:

- Material: see table below
- Pipe outside diameter see table below
- Pipe wall thickness see table below

Elastomeric foamed thermal insulation:

- For material type refer to 8.2.12
- Insulation thickness: see table below
- Installation situation is LS and CS
- Minimum insulation length ($L_D \geq 250$ mm) on both sides of the floor

Gap size and Gap filler:

- Gap size is 5 mm to 30 mm
- Gap filler is CFS-FIL
- Installation depth: ($t_{A3} \geq 25$ mm) on each side of the floor

Collar fixing in pipe group 1 and 2:

- For perpendicular situation (90°): refer to 8.2.4 and Tab.3, for hook fixing refer to 8.2.3 and Tab.2

Rigid floor ($t_E \geq 150$ mm)			
Pipe material	PE	PE	PP
Norm/standard/ Producer/product	EN 1519-1, EN12666-1, EN 12201-2	Non-regulated, Geberit Silent dB20	Non-regulated, See 8.2.15
Pipe diameter d_c	Pipe group 1: ($40 \leq d_c \leq 110$ mm) Pipe group 2: see graphic 8.5.2.44 A below	Pipe group 1: ($40 \leq d_c \leq 110$ mm) Pipe group 2: see graphic 8.5.2.44 B below	Pipe group 1: See graphic 8.5.2.44 C Pipe group 2: 8.5.2.44 D below
Pipe wall thickness t_c	Pipe group 1: ($t_c = 4,2$ mm) Pipe group 2: see graphic 8.5.2.44 A below	Pipe group 1: ($t_c = 6,0$ mm) Pipe group 2: see graphic 8.5.2.44 B below	Pipe group 1: See graphic 8.5.2.44 C Pipe group 2: 8.5.2.44 D below
Insulation thickness t_D	($t_D = 19$ mm)	($t_D = 19$ mm)	($t_D = 19$ mm)
Classification	pipe group 1: EI 120 pipe group 2: EI 180	pipe group 1: EI 180 pipe group 2: EI 240	group 1 and 2: EI 120

Pipe Range 8.5.2.44 A:

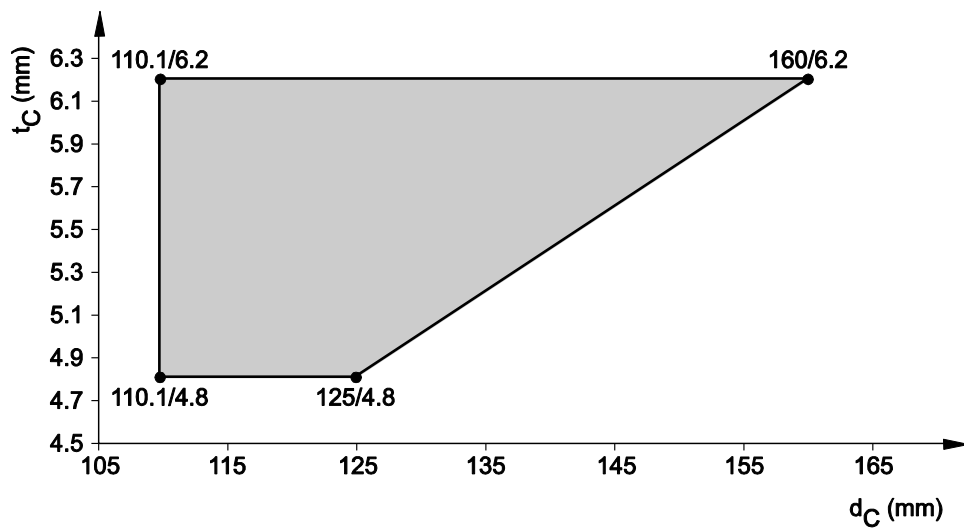

Pipe Range 8.5.2.44 B:

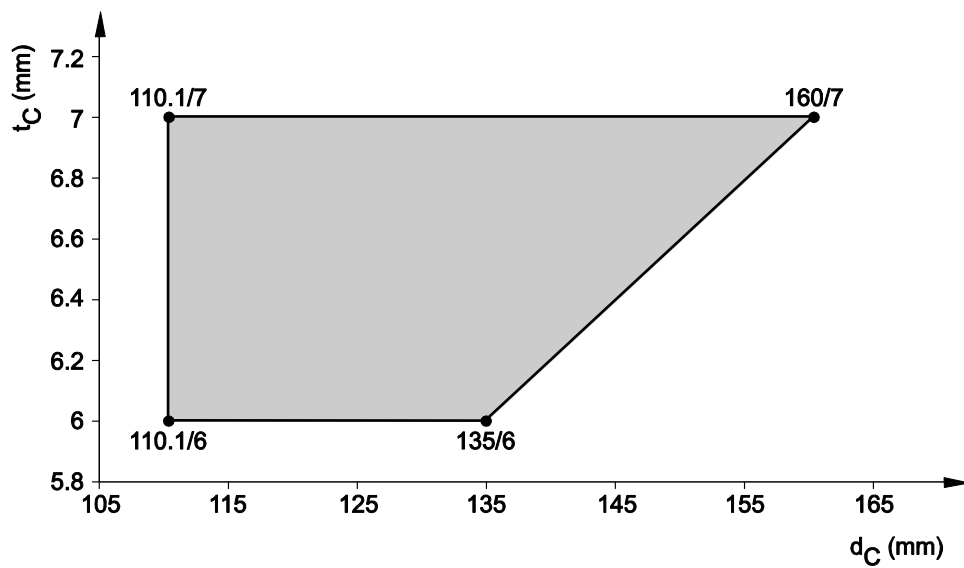

Pipe Range 8.5.2.44 C:

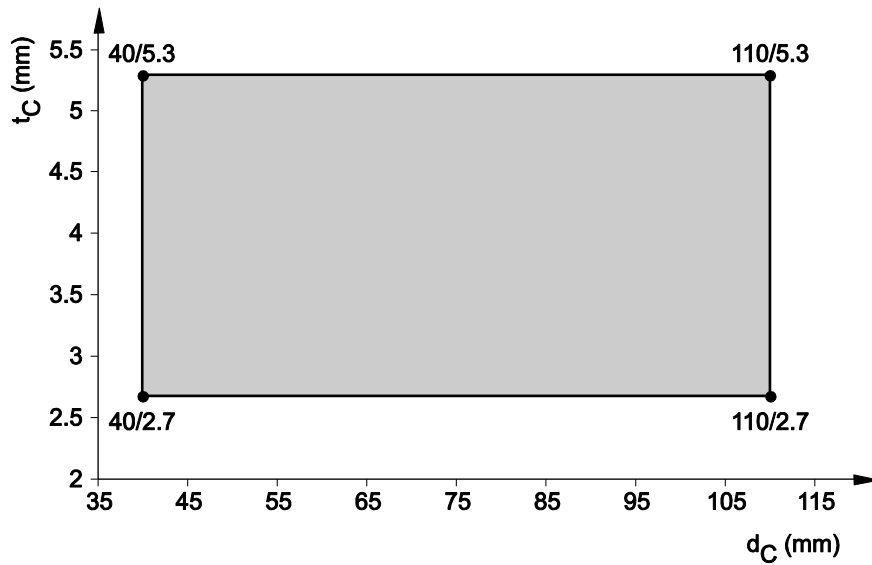

Pipe Range 8.5.2.44 D:

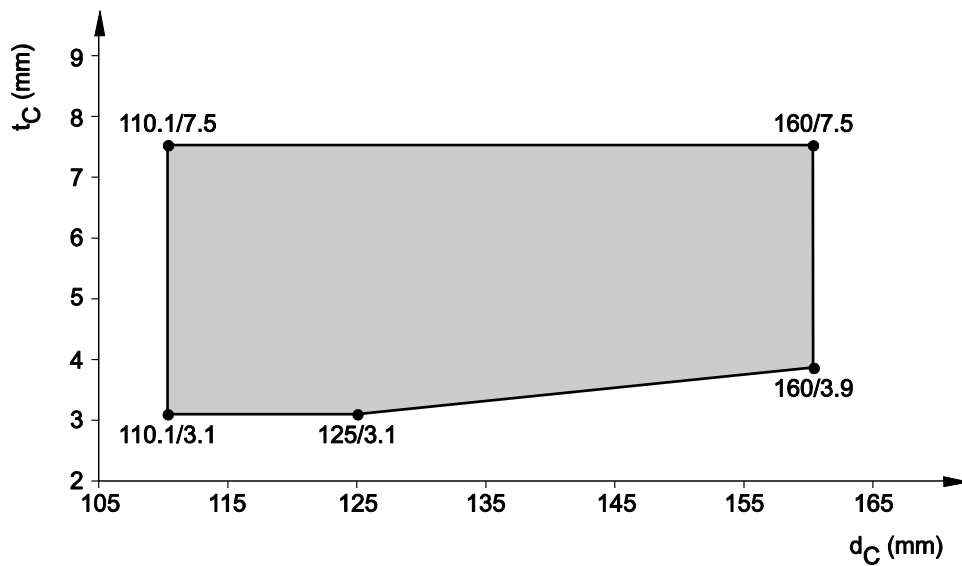

8.5.2.45 Pipe junction/manifold inside the floor, assessed in rigid floor ($t_E \geq 150$ mm), pipe group 1 and 2, EI 120 - U/U, EI 90 - U/U and EI 60 - U/U

Assessed situation:

- An U/U classified waste water pipe (C) penetrating a floor in perpendicular situation, sealed with CFS-C EL on soffit only (refer to 8.5.2)
- Inside the floor there are one or more pipe junctions/manifolds into the central waste water pipe, where horizontal running minor pipes flow into the central waste water pipe
- Those minor pipes are always in U/C constellation
- For pipe material / pipe dimension of (C) see Tab.4 below, for classification see Tab.4 below
- Pipe diameter ($32 \leq d_c \leq 160$ mm)
- Gap sealing: refer to 8.5.1.2
- Arrangement of smaller pipes in U/C constellation: in line
- Number of smaller pipes in U/C constellation: unlimited
- Distance pipe to pipe between smaller pipes in U/C constellation: $s_1 \geq 15$ mm
- Distance between U/U classified main waste water pipe (C) and smaller pipes in U/C constellation: $s_1 \geq 15$ mm

Chapter within this ETA, describing assessed pipe dimensions and material for (C)	For EI 120 – U/U:	For EI 90 – U/U:	For EI 60 – U/U:
8.5.2.1	x	x	x
8.5.2.2	x	x	x
8.5.2.3	x	x	x
8.5.2.4	x	x	x
8.5.2.5		x	x
8.5.2.6	x	x	x
8.5.2.7	x	x	x
8.5.2.8		x	x
8.5.2.10	x	x	x
8.5.2.11	x	x	x
8.5.2.14	x	x	x
8.5.2.15	x	x	x
8.5.2.16			x
8.5.2.17		x	x
8.5.2.19	x	x	x
8.5.2.20		x	x
8.5.2.21	x	x	x
8.5.2.22	x	x	x
8.5.2.25	x	x	x
8.5.2.26	x	x	x

Tab.4: Assessed classification for vertical positioned waste water pipes (C) with plastic pipe junctions/manifolds located within the floor itself, connecting the main pipe (C) with smaller, nearly horizontal running plastic pipes as shown below:

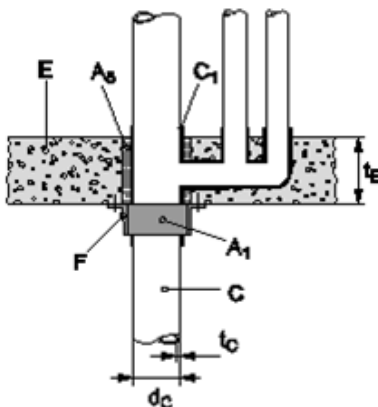

8.5.2.46 **PP pipes acc. EN 1451-1 and DIN 8077/78 in rigid floor ($t_E \geq 150$ mm), pipe group 1,
EI 120 - U/U, Pipe coupling**

Situation for EI 120 - U/U:

- Pipe coupling inside the wall, half in the wall or outside the wall, covered by CFS-C EL
- Type of pipes: PP pipes acc. EN 1451-1
- Pipe sound decoupling insulation: see 8.2.6

Pipe range:

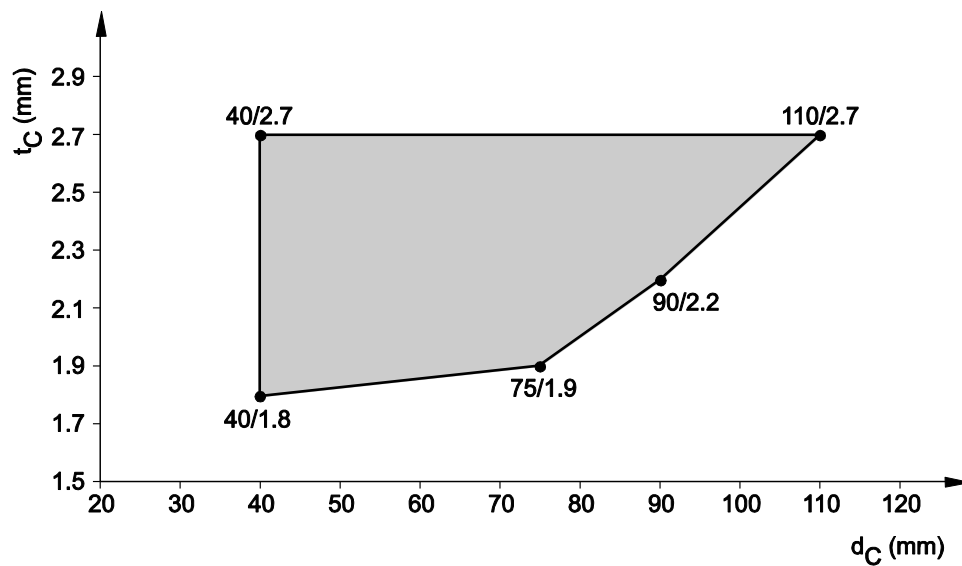

Gap size and gap filler:

In rigid wall application ($t_E \geq 150$ mm):

- Gap filler: Hilti CFS-FIL
- Annular gap: 5 – 30 mm
- Depth t_{A2} to be filled with Hilti CFS-FIL: ($t_{A2} \geq 25$ mm)
- No backfilling required

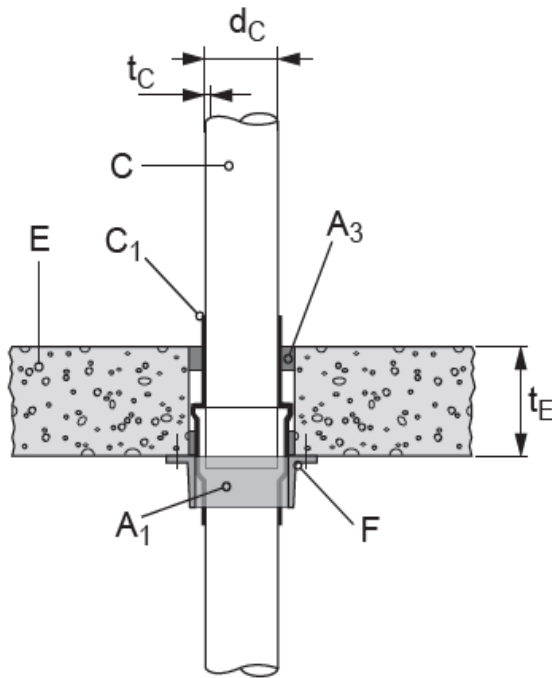

Requested number of hooks:

Pipe outside nominal diameter d_C (mm)	Acoustic Pipe Insulation Thickness t_D (mm)		
	(incoming pipe / outgoing pipe)		
	0	4	9
40	2 / 2	2 / 2	2 / 2
41 - 75	3 / 3	3 / 3	3 / 3
76 - 90	3 / 3	3 / 3	3 / 3
91 - 110	4 / 4	4 / 4	4 / 4

If pipe insulation thickness is between 0 and 4 mm use the number of hooks indicated for 4 mm.
 If pipe insulation thickness is between 4 and 9 mm use the number of hooks indicated for 9 mm.

8.5.2.47 **PP pipes acc. EN 1451-1 and DIN 8077/78, in rigid floor ($t_E \geq 150$ mm), pipe group 1, EI 120 - U/U, Pipe Elbow 87°**

Situation for EI 120-U/U:

- Elbow connector (87°), Elbow partly inside the floor, covered by CFS-C EL
- On one side the pipe may run parallel to the floor having a zero distance to floor ($s_3 \geq 0$ mm).

Pipe range:

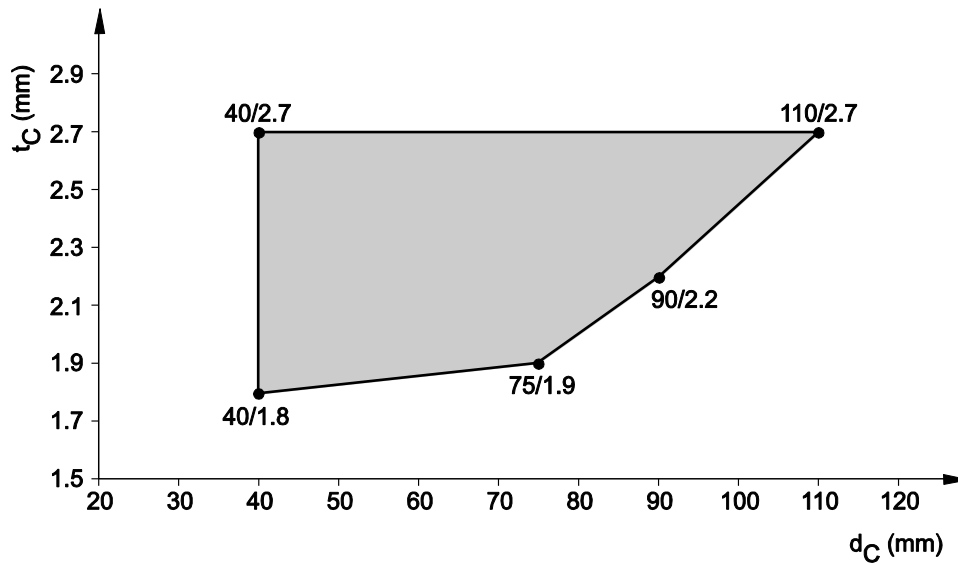

Gap size and Gap filling:

- Gap filler: Hilti CFS-S ACR
- Annular gap: 0 – 15 mm
- Depth t_{A2} to be filled with Hilti CFS-S ACR: ($t_{A2} \geq 25$ mm)
- No backfilling required
- or:
- Gap filler: Hilti CFS-S ACR
- Annular gap: 0 – 40 mm
- Depth t_{A2} to be filled with Hilti CFS-S ACR: ($t_{A2} \geq 25$ mm) on the upper side of the floor only
- Backfilling required, refer to Annex 2, chapter 7.2
- or:
- Gap filler: cementitious Mortar M10 acc. EN 998-2
- Annular gap: 0 – 40 mm
- Depth to be filled with cementitious Mortar M10: to fill over entire floor thickness

Collar fixing:

- Refer to 8.2.3

Number of hooks:

Pipe outside nominal diameter d_c (mm)	Acoustic Pipe Insulation Thickness t_D (mm)		
	(no elbow side - vertical running pipe / elbow side - horizontal running pipe)		
	0	4	9
40 - 74	3 / 3	3 / 3	3 / 3
75 - 109	3 / 3	3 / 3	3 / 3
110	4 / 4	4 / 4	4 / 4

If pipe insulation thickness is between 0 and 4 mm use the number of hooks indicated for 4 mm.
 If pipe insulation thickness is between 4 and 9 mm use the number of hooks indicated for 9 mm.

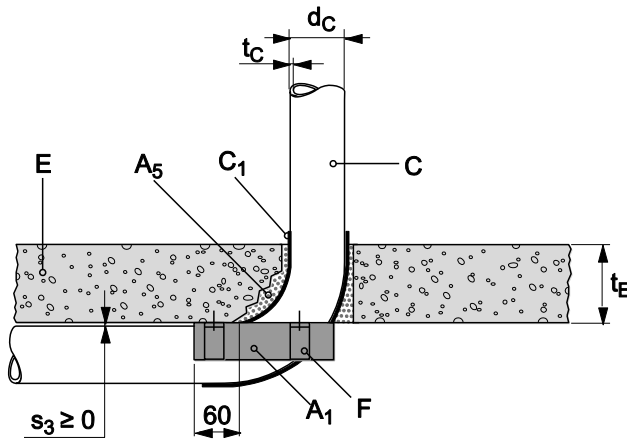

8.5.2.48 PVC pipes acc. EN 1452-1, EN 1329-1, EN 1453-1, EN 1566-1; DIN 8061/62, EN ISO 15493 in rigid floor ($t_E \geq 150$ mm), pipe group 1, EI 120 - U/U, Pipe Elbow 87°

Situation for EI 120-U/U:

- Elbow connector (87°), Elbow partly inside the floor, covered by CFS-C EL
- On one side the pipe may run parallel to the floor having a zero distance to floor ($s_3 \geq 0$ mm).

Pipe range:

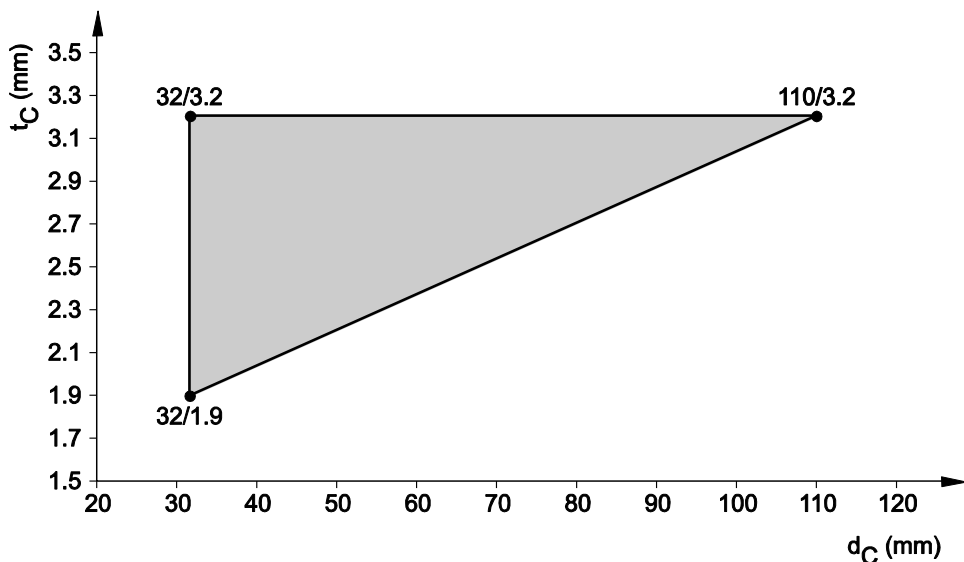

Gap size and Gap filling:

- Gap filler: Hilti CFS-S ACR
- Annular gap: 0 – 15 mm
- Depth t_{A2} to be filled with Hilti CFS-S ACR: ($t_{A2} \geq 25$ mm)
- No backfilling required
- or:
- Gap filler: Hilti CFS-S ACR
- Annular gap: 0 – 40 mm
- Depth t_{A2} to be filled with Hilti CFS-S ACR: ($t_{A2} \geq 25$ mm) on the upper side of the floor only
- Backfilling required, refer to Annex 2, chapter 7.2
- or:
- Gap filler: cementitious Mortar M10 acc. EN 998-2
- Annular gap: 0 – 40 mm
- Depth to be filled with cementitious Mortar M10: to fill over entire floor thickness

Collar fixing:

- Refer to 8.2.3

Number of hooks:

Pipe outside nominal diameter d_c (mm)	Acoustic Pipe Insulation Thickness t_D (mm) (no elbow side - vertical running pipe / elbow side - horizontal running pipe)		
	0	4	9
32 - 109	3 / 3	3 / 3	3 / 3
110	4 / 4	4 / 4	4 / 4

If pipe insulation thickness is between 0 and 4 mm use the number of hooks indicated for 4 mm.
 If pipe insulation thickness is between 4 and 9 mm use the number of hooks indicated for 9 mm.

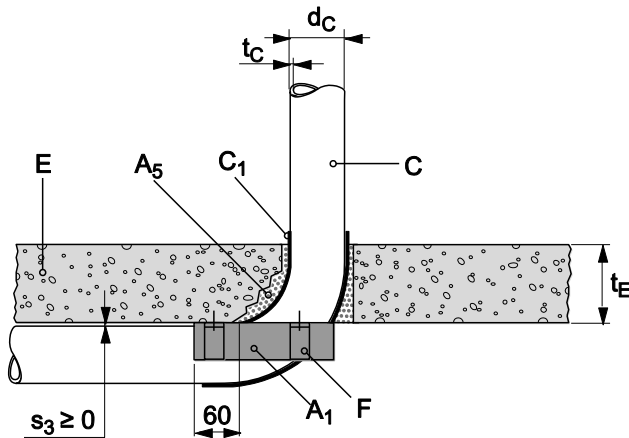

8.5.2.49 Wavin Tigris PE-X - one pipe in rigid floor ($t_E \geq 150$ mm), pipe group 1, EI 90 - U/C

Situation for EI 90-U/:

- Pipe (C) penetrates perpendicular the wall
- Single penetration (C) or bunched pipes
- Pipes are fire sealed from the soffit only

Type and dimensions of pipes:

- Type: Wavin Tigris PE-X-One R-I-R insulated
- for pipe dimension refer to table below
- Insulation: PE-foam, CS, for dimension refer to table below, for material refer to 8.2.13
- Additional protection: R-I-R Hardcover, PE-HD, CS and CI, covering pipe and insulation

Nr.	Material Standard	Pipe diameter (mm)	Pipe wall thickness (mm)	Pipe insulation thickness (mm)
1	PE-X in PE hardcover	12	2,0	9
2	PE-X in PE hardcover	15	2,5	10
3	PE-X in PE hardcover	18	2,5	10 - 20
4	PE-X in PE hardcover	22	3,0	13 - 20

Gap size and Gap filling:

With mortar M10 acc. EN 988-2 (A_5):

- Annular gap width ($0 \leq s_3 \leq 15$ mm)
- Installation depth: over the entire floor thickness t_E

With CFS-S ACR or CFS-IS (A_2):

- Annular gap width ($0 \leq s_3 \leq 15$ mm)
- Installation depth: min. 15 mm from both sides of the floor
- With or without backfilling B (mineral wool, density ≥ 40 kg/m³), reaction to fire class: min. A2-s1, d0

For cluster or linear arrangements:

- Triangular clusters and pipes in line (horizontal/vertical)
- Number of pipes in cluster defined by max. collar diameter / perimeter length see below
- Minimum distance between clustered pipes: $s_2 \geq 0$ mm

Collar seal CFS-C EL:

- CFS-C EL fits tightly around the cluster or linear arrangement
- Max. collar diameter: 80 mm
- Max. collar perimeter length: 550 mm
- Fixing with 3 hooks for single and multiple penetration (clusters)

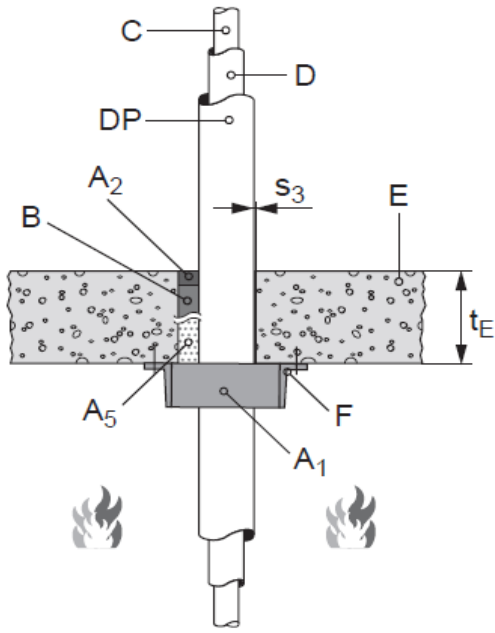

Wavin Tigris PE-X-One R-I-R insulated, penetrating a rigid floor

electronic copy electronic copy electronic copy electronic copy electronic copy electronic copy electronic copy electronic copy electronic copy electronic copy

8.6 Shaft walls

8.6.1 Specific characteristics for Shaft walls

8.6.1.1 Suitable Shaft wall system A: 2 x 25 mm

Hilti Firestop Collar Endless CFS-C EL (A_1) can be used to seal plastic pipes installed in shaft wall systems classified at least with EI 90 according EN 13501-2. The mechanical resistance and stability have to be proven for the required fire resistance period. The Shaft Wall should consist of the following components:

Plates: Two layers each of 25 mm Knauf Fireboard plates (acc. EN 15283-1), combustibility class A1 acc. EN 13501-1

Track and Studs:

CW and UW Profil 75,

Track should be minimum a 75 mm x 40 mm x 0,6 mm thick galvanized mild steel,
Stud should be minimum a 73,5 mm x 43,5 mm x 0,55 mm thick galvanized mild steel.

Fixing/Screws:

First layer should be fixed using 35 mm long x 3,5 mm diameter flexible wall screws,
second layer should be fixed with 55 mm long x 3,5 mm diameter flexible wall screws.

Gypsum: Knauf Fireboard Spachtel, gypsum-based plaster or similar.

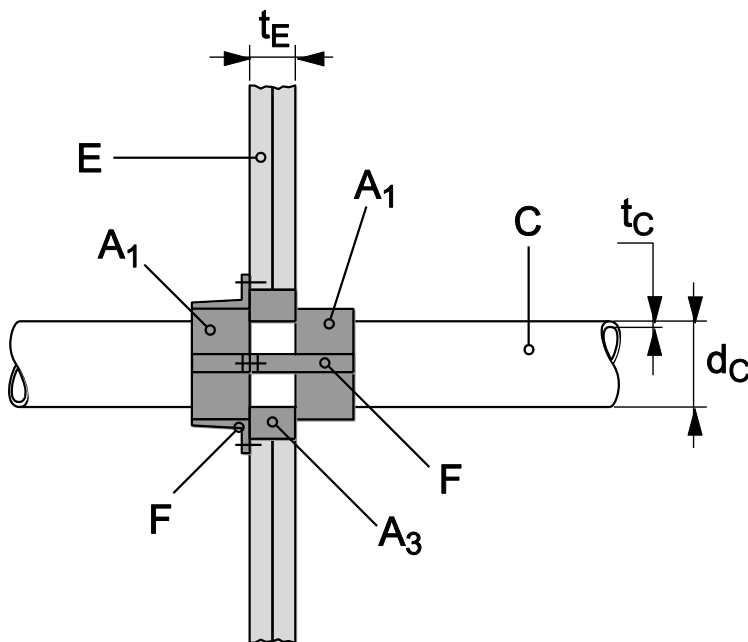

8.6.1.2 Suitable Shaft wall system B: 3 x 15 mm

Hilti Firestop Collar Endless CFS-C EL (A₁) can be used to seal plastic pipes, aluminum composite pipes and electrical application installed in shaft wall systems classified at least with EI 90 according EN 13501-2. The mechanical resistance and stability have to be proven for the required fire resistance period. The Shaft Wall should consist of the following components:

Plates: Minimum three layers each of ≥ 15 mm gypsum boards (acc. EN 520), type DF, max. height: 300 cm, max. width 125 cm.

Track and Studs:
 CW and UW Profil, size 50 or bigger (acc. EN 14195),
 Profiles should be minimum a 50 mm x 50 mm x 0,6 mm thick galvanized preformed steel sheet.

Fixing/Screws:
 First layer should be fixed using 25 mm long x 3,5 mm diameter flexible wall screws,
 second layer should be fixed with 45 mm long x 3,5 mm diameter flexible wall screws,
 third layer should be fixed using 55 mm x 3,5 mm diameter flexible wall screws.

Gypsum: gypsum-based plaster.

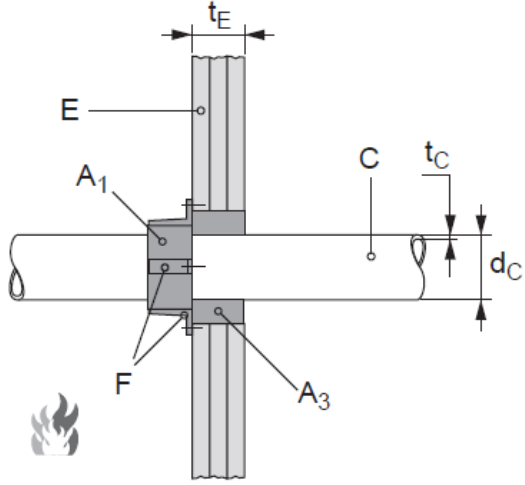
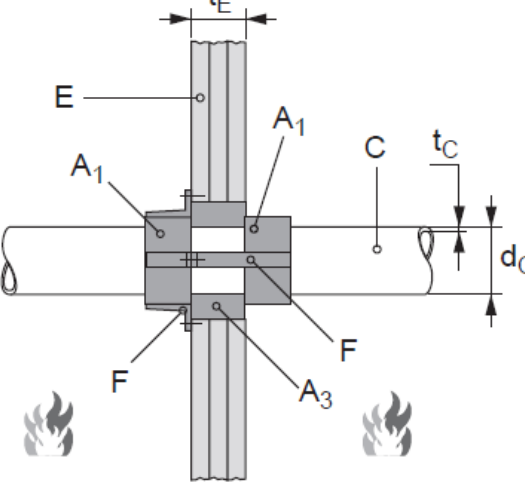
	<p>8.6.1.2 A:</p> <p>For shaft wall system B only.</p> <p>Fire load is definitely from one side only, so firestop has to be installed on one side only.</p> <p>A second firestop on the other side of the firewall is not necessary.</p>
	<p>8.6.1.2 B:</p> <p>For shaft walls system B only.</p> <p>Fire load from both sides possible, so firestop must be done on both sides of the wall.</p> <p>Installation from one side of the wall possible (no access form the other side).</p>

8.6.1.3 Penetrating pipes/cables/conduits:

For shaft walls system A: 2 x 25 mm (refer to 8.6.1.1)

- Plastic pipes in pipe group 1, nominal pipe outside diameter ($d_c \leq 110$ mm),
- only single penetration seals,
- Hilti Firestop Collar Endless CFS-C EL (A_1) on both sides of the shaft wall,
- For pipe material and pipe dimension refer to 8.6.2

For shaft walls system B: 3 x 15 mm (refer to 8.6.1.2)

- Plastic pipes in pipe group 1, nominal pipe outside diameter ($d_c \leq 110$ mm) in perpendicular installation, coupling and elbow configuration,
- Polyethylene insulated aluminum composite pipes,
- Cables, all types, up to 21 mm diameter, bunched cables,
- Rigid, flexible and pliable conduits,
- Single penetration seal, multiple and mixed penetration seal,
- Hilti Firestop Collar Endless CFS-C EL (A_1) on both sides of the shaft wall,
- For pipe-, conduit-, and cable-specification, dimension and installation details refer to 8.6.2

8.6.1.4 Annular Gap

- For shaft wall system A (refer to 8.6.1.1): annular gap around single penetrating plastic pipes should be 15 - 20 mm.
- For shaft wall system B (refer to 8.6.1.2): annular gap around single penetrating items (plastic pipes, aluminum composite pipes, cables, bunched cables, conduits) and multiple or mixed seals using CFS-C EL collar is 5 - 15 mm (if only one collar on pipe has been used) or 15 - 20 mm (if two collars on pipe have been used). For CFS-W P wrap application annular gap is always 0 - 15 mm.

8.6.1.5 Gap Filler in Shaft Walls

- Hilti CFS-FIL to be used as filler for shaft wall system A and B
- CFS-FIL has to be applied from one side over the entire thickness of the wall.
- Consider the Instruction for Use (Annex 5)

8.6.1.6 Firestop installation

- Collar CFS-C EL installation in shaft walls system A and B can be done from one side only (limited access to the other side)
- CFS-W P wrap installation can be done from one side only (in shaft wall system B only)

8.6.1.7 Collar fixing

- For number of hooks refer to 8.2.4 and Tab 3
- For hook fixing refer to 8.2.3 and Tab 2
- Fixing of all hooks from one side of the wall possible
- Due to one side installation long and short hooks are requested
- Consider the identical number of long and short hooks
- One long and one short hook may be fixed to the wall using a single point of fixing or using separate hooks

8.6.1.8 Pipe support

- Pipes shall be supported at maximum 250 mm away from both faces of wall constructions system A and B (first support)

8.6.1.9 **Recycling of oddments**

- No oddments should be used

8.6.1.10 **Pipe orientation**

- All pipes must penetrate the shaft wall in a perpendicular orientation only

8.6.1.11 **Minimum distance pipe to pipe in shaft walls**

- For shaft wall type A - see 8.6.1.1: the minimum distance pipe to pipe penetrating a shaft wall and sealed by using Hilti Firestop Collar CFS-C EL distance should be 200 mm. Direct contact pipe to pipe (in line or in cluster) are not assessed.
- For shaft wall type B - see 8.6.1.2: pipes may be in direct contact (zero distance pipe to pipe), sealed by one or two collar seals CFS-C EL. For details refer to 8.6.3.

8.6.1.12 **Sound decoupling C₁ on plastic pipes**

For shaft wall type A - 8.6.1.1: no sound decoupling should be applied

For shaft wall type B - 8.6.1.2:

- Material: soft polyethylene foam/foil, refer to 8.2.6
- Thickness: 0 - 4 mm
- Position: on the pipe penetrating the wall, below the collar or collars (only within the wall and beneath the collar/collars)
- Length: minimum 95 or 145 mm (one or two collars have been used), maximum length unlimited

8.6.2 **Penetration service in shaft walls system A: 2 x 25 mm (refer to 8.6.1.1)**

8.6.2.1 **PE pipes acc. EN 1519-1, EN 12201-2 and EN 12666-1, in shaft wall system A, pipe group 1, EI 90 - U/U**

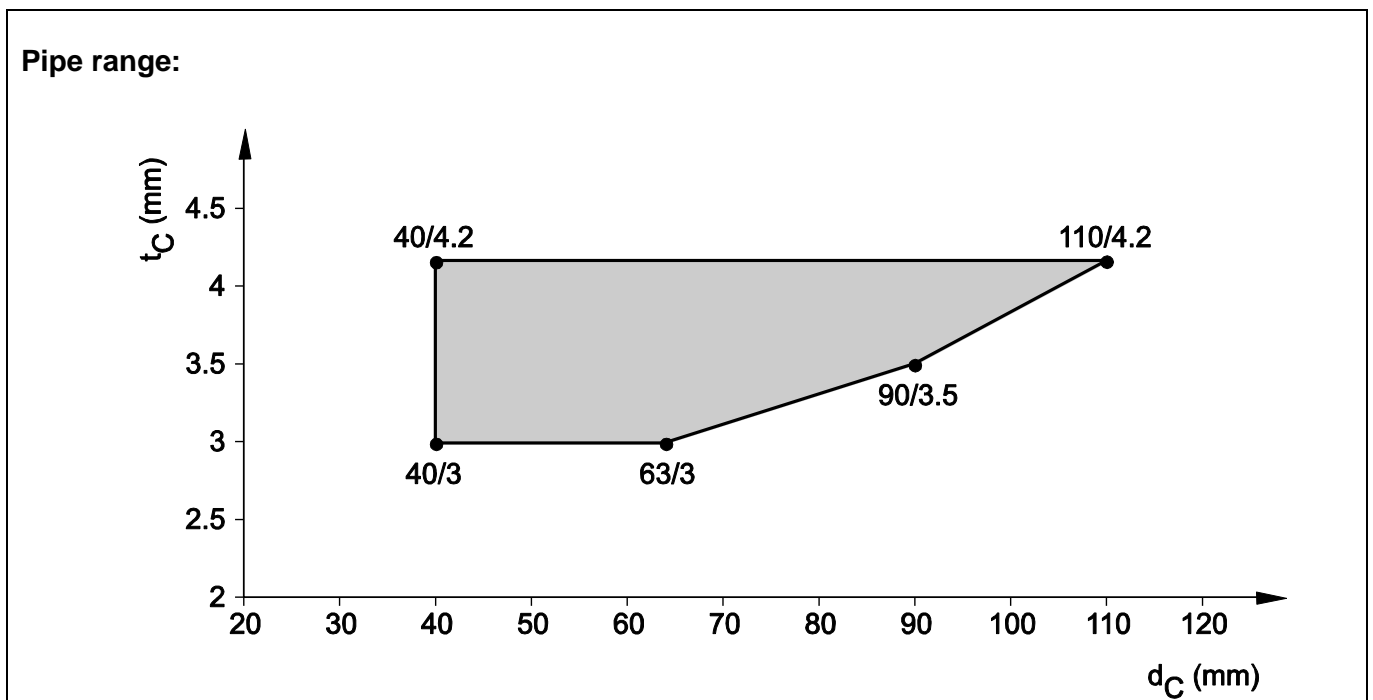

8.6.2.2 PE pipes acc. EN 15494, EN 12201-2 and DIN 8074/75, in shaft wall system A,
pipe group 1, EI 90 - U/U

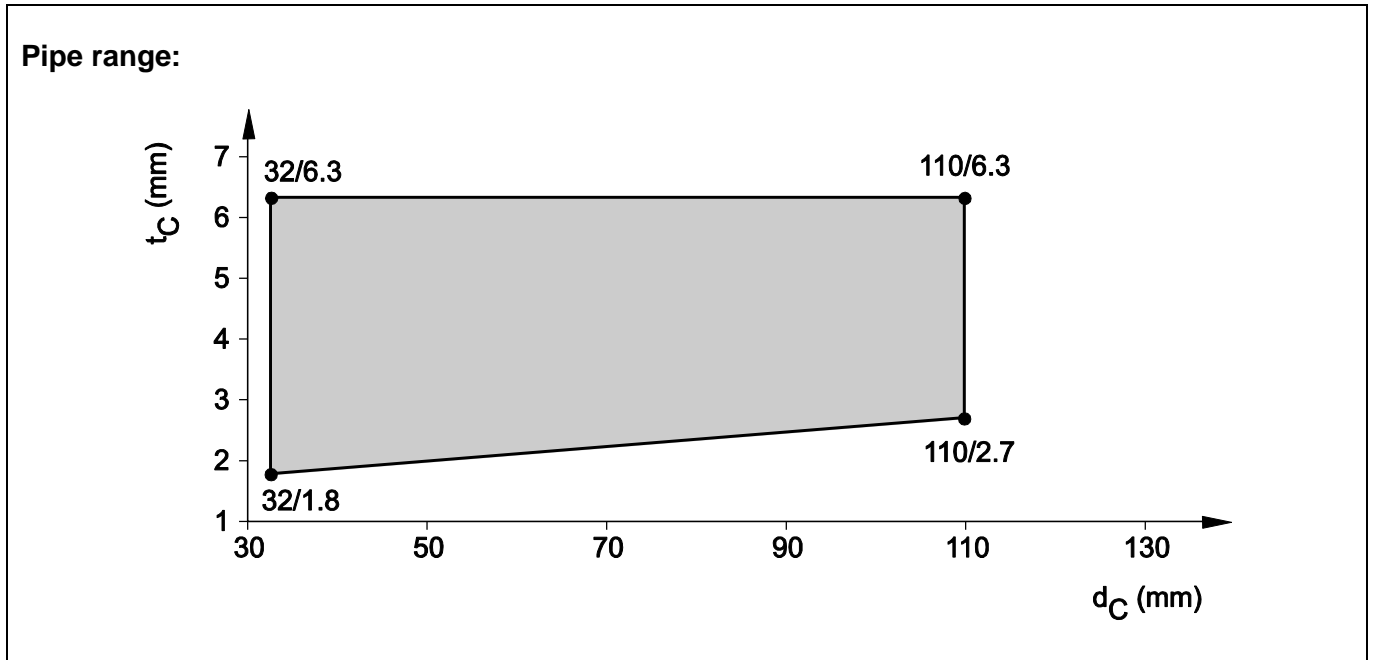

8.6.2.3 PVC pipes acc. EN 1452-1, EN 1329-1, EN 1453-1, EN 1566-1, EN ISO 15493 and
DIN 8061/62, in shaft wall system A, pipe group 1, EI 90 - U/U

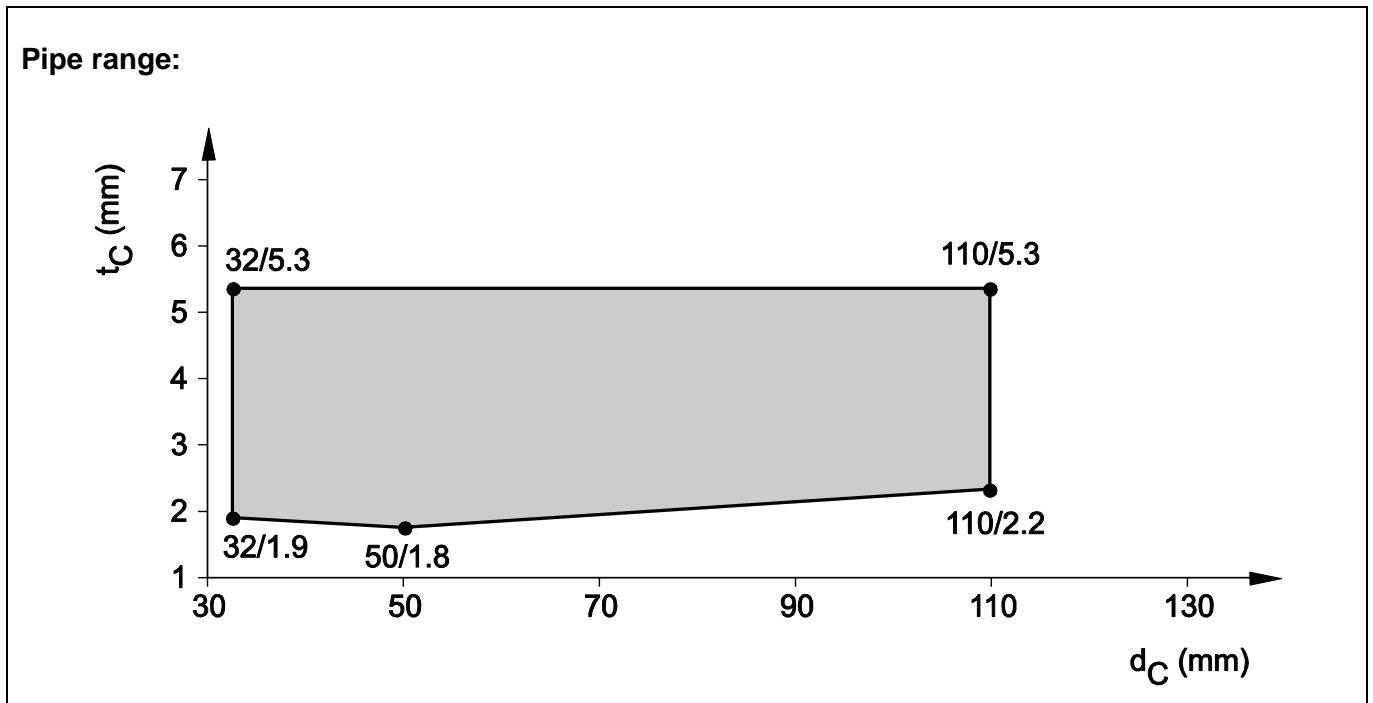

8.6.2.4 PP pipes, non-regulated, in shaft wall system A, pipe group 1, EI 90 - U/U

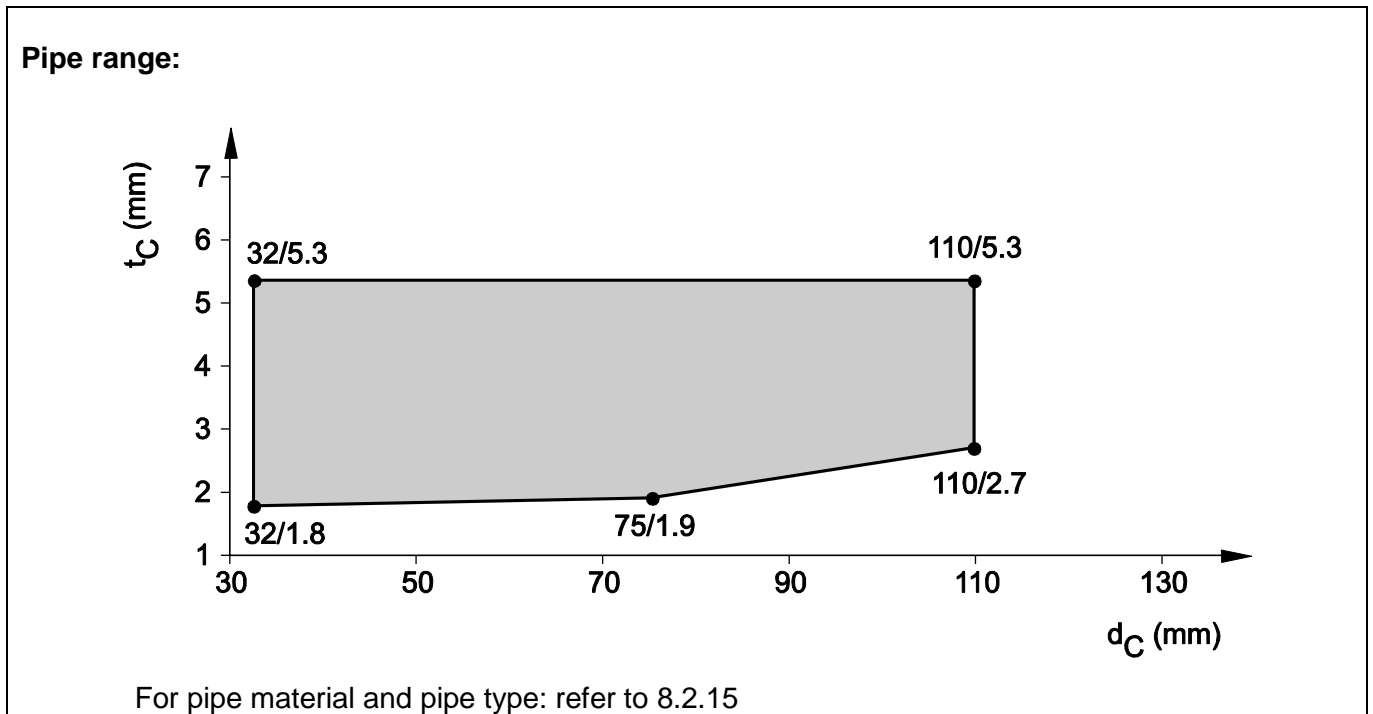

8.6.2.5 PP pipes acc. EN 1451-1 and DIN 8077/78, in shaft wall system A, pipe group 1, EI 90 - U/U

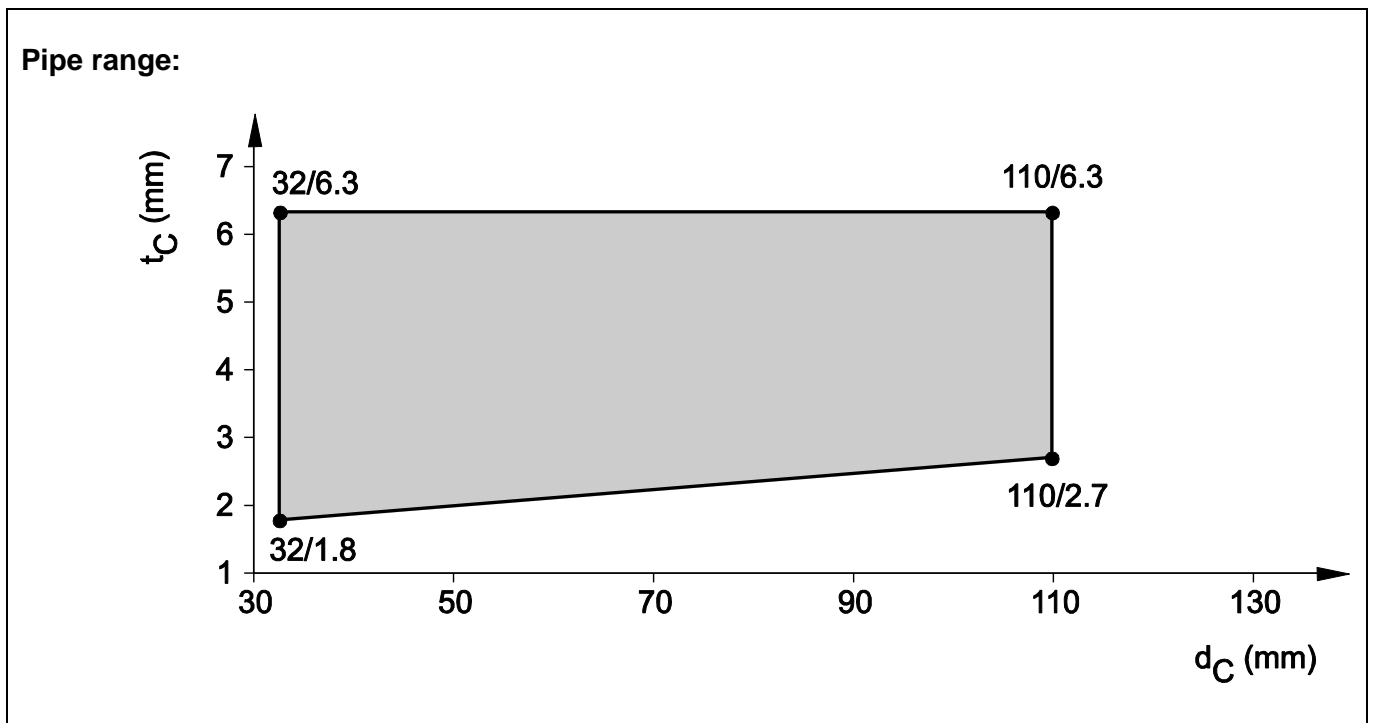

8.6.2.6 PE pipes non-regulated (Geberit Silent dB20), in shaft wall system A, pipe group 1, EI 90 - U/U

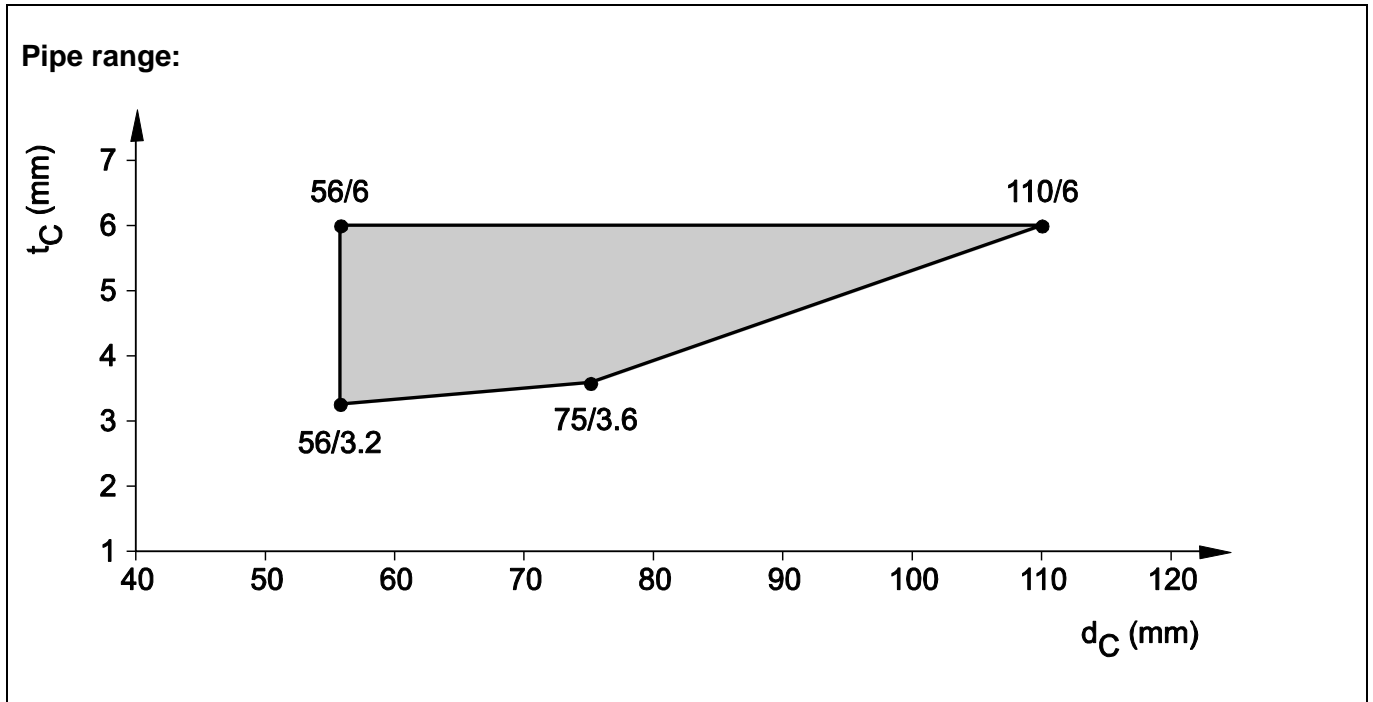

8.6.2.7 ABS pipes acc. EN 1455-1, EN 15493 and SAN+PVC-pipes acc. EN 1565-1, in shaft wall system A, pipe group 1, EI 90 - U/U

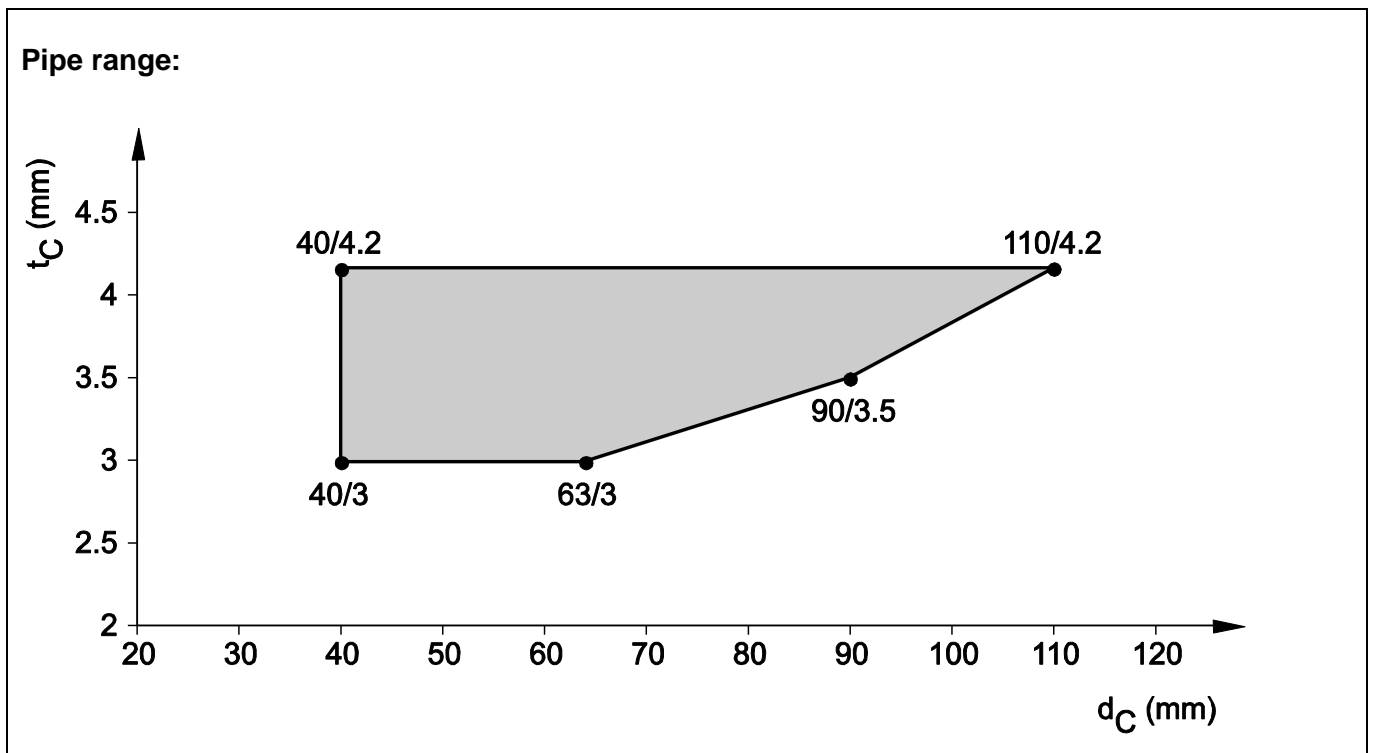

8.6.3 Penetration service in shaft walls system B: 3 x 15 mm (refer to 8.6.1.2)

8.6.3.1 PE pipes acc. EN 1519-1, EN 12201-2 and EN 12666-1, in shaft wall system B, pipe group 1, EI 90 - U/U

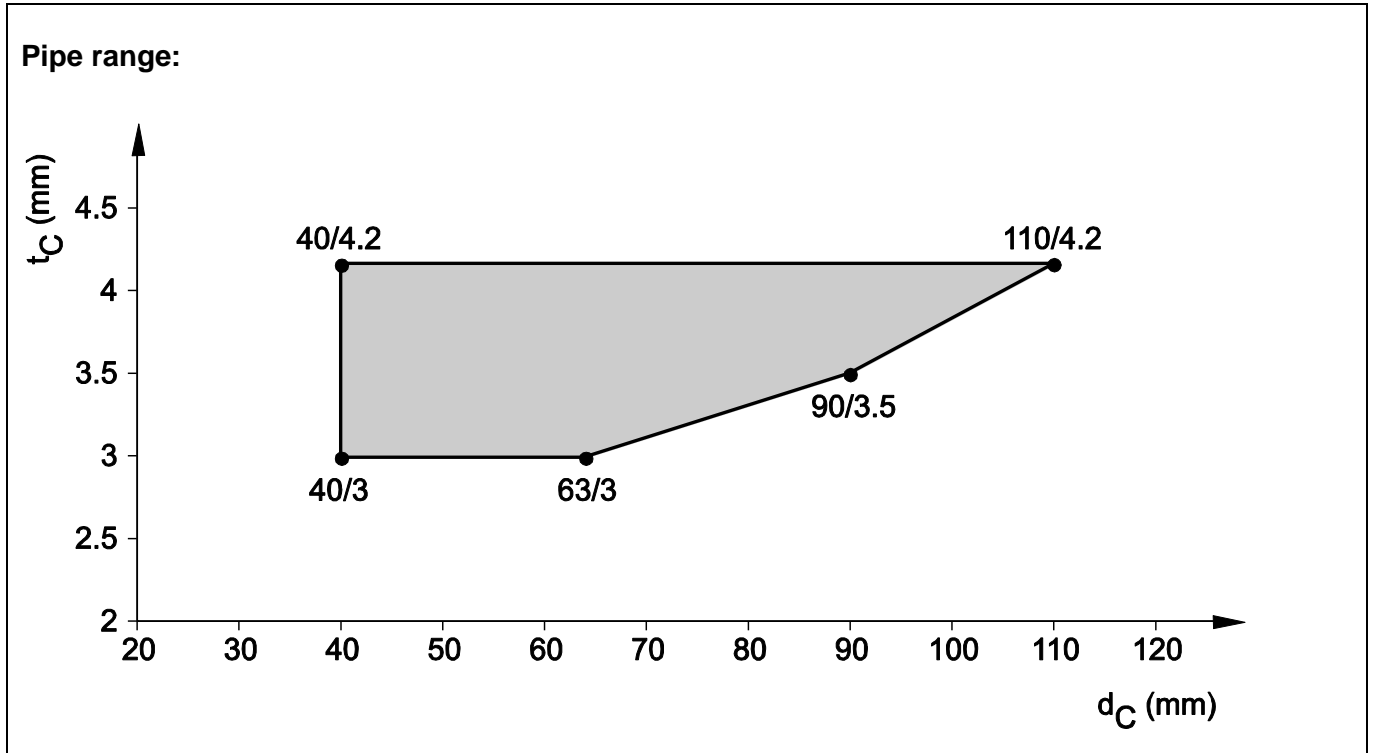

8.6.3.2 PP pipes, non regulated, in shaft wall system B, pipe group 1, EI 90 - U/U

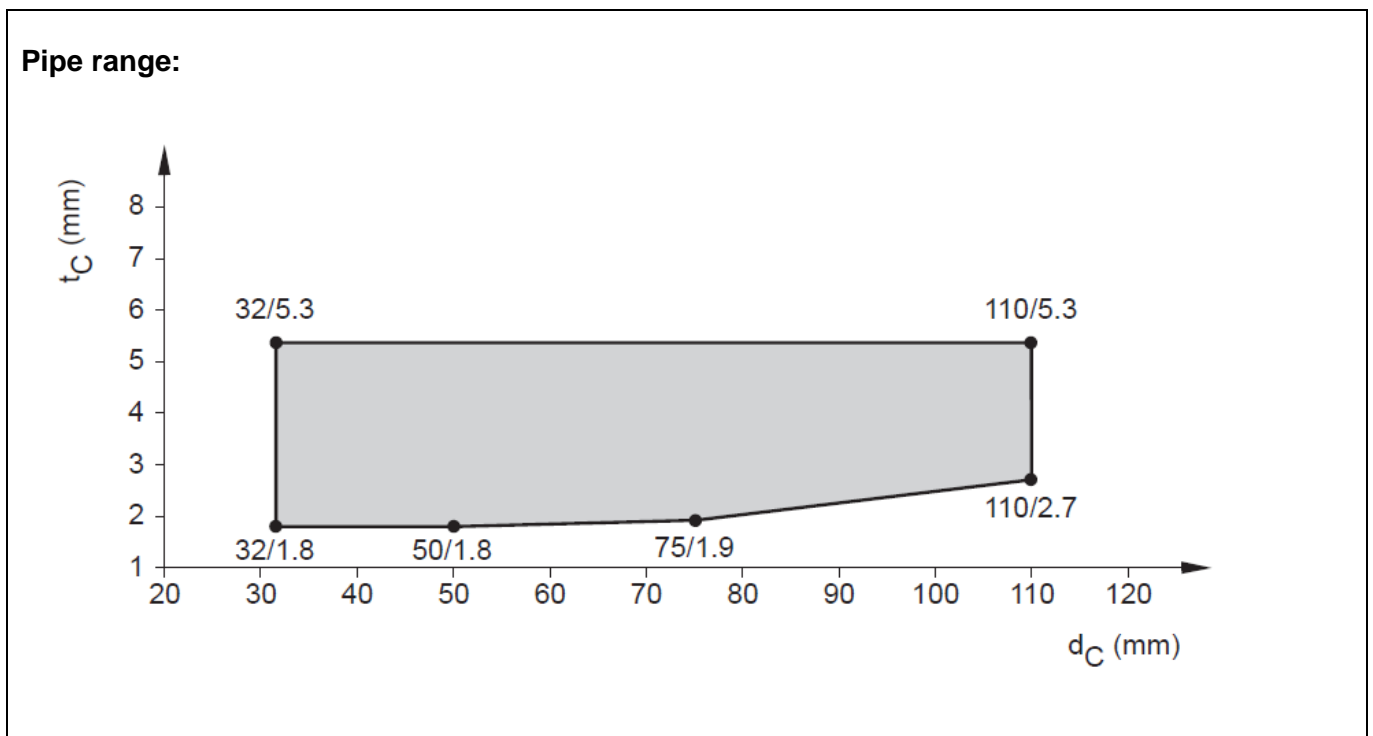

8.6.3.3 PE pipes, non-regulated (Geberit Silent dB20) in shaft wall system B, pipe group 2, EI 90 - U/U

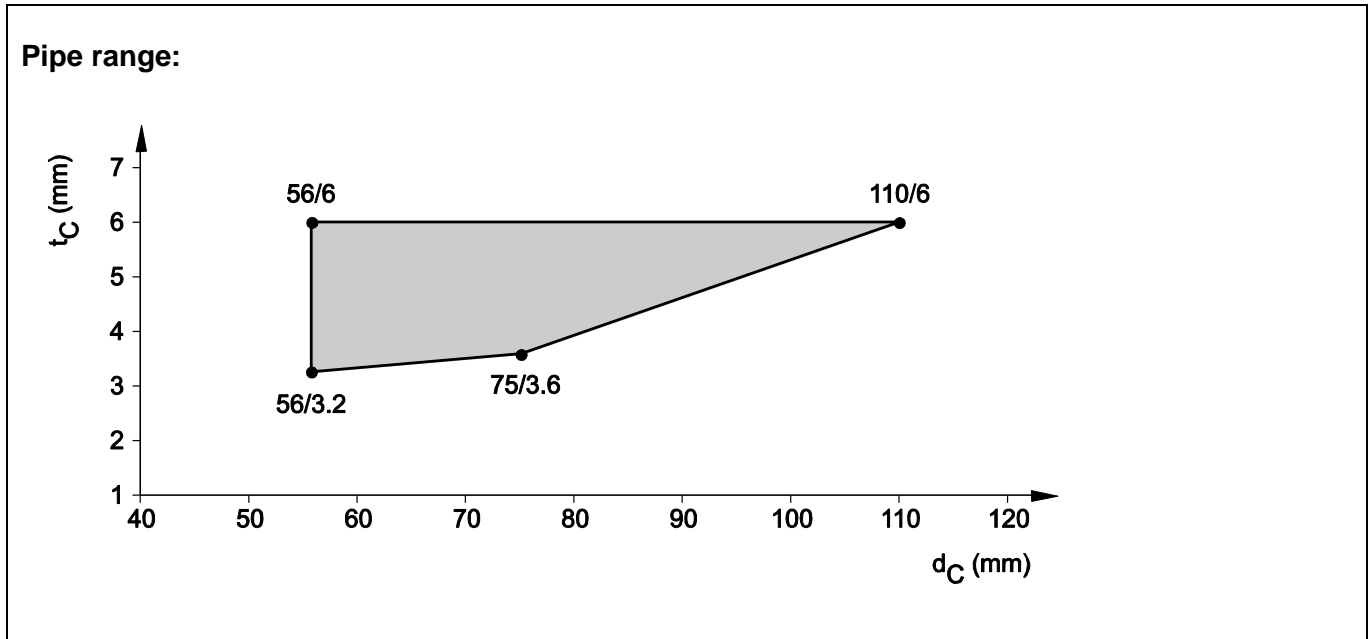

8.6.3.4 Plastic pipes, with 1x 87° elbow in shaft wall system B (refer to 8.6.1.3), EI 90 - U/U

Situation for EI 90 - U/U:

- Elbow Pipe 87° inside the wall or half in the wall, covered by CFS-C EL collar
- Type of pipes refer to 8.6.3.1, 8.6.3.2, 8.6.3.3
- Range (dimension) of pipes refer to 8.6.3.1, 8.6.3.2, 8.6.3.3
- On one side the pipe may run with zero distance to penetrated wall ($s_3 > 0$ mm).
- One or two collars can be used, depending from possible fire load (refer to 8.6.1.2)

Gap size and gap filler:

- Gap filler: Hilti CFS-FIL
- Annular gap: 5 – 15 mm for one-collar application (collar has not to pass through the wall)
- Annular gap: 15 – 20 mm for two-collar application (collar has to pass through the wall)
- Depth t_{A3} of installed gap filler: over the entire wall thickness t_E
- No backfilling required

With or without acoustic pipe decoupling/insulation: see 8.6.1.12

Requested number of hooks:

Pipe outside nominal diameter d_C (mm)	Number of hooks to be used: <small>(no elbow side - horizontal running pipe / elbow side - vertical running pipe)</small>	
	One collar – one side fire load only	Two collars – potential fire load from both sides
32	2 / 0	2 / 4
40	3 / 0	3 / 4
50	3 / 0	3 / 4
56	3 / 0	3 / 4
63	4 / 0	4 / 4
75	4 / 0	4 / 4
90	4 / 0	4 / 4
110	4 / 0	4 / 5

	<p>8.6.3.4 A:</p> <p>Elbow installation with double side potential fire load.</p>
	<p>8.6.3.4 B:</p> <p>Possible hook configuration on vertical running pipes, depending from pipe diameter</p>
	<p>8.6.3.4 C:</p> <p>Elbow installation with single side potential fire load.</p>

8.6.3.5 Plastic pipes, with 2 x 45° elbow in shaft wall system B (refer to 8.6.1.2), EI 90 - U/U

Situation for EI 90 - U/U:

- 2 x Elbow Pipe 45° inside the wall or half in the wall, covered by CFS-C EL collar
- Type of pipes: refer to 8.6.3.1, 8.6.3.2, 8.6.3.3
- Range (dimension) of pipes:
 - For non-regulated PP – pipes: diameter 110 mm, wall thickness 2,7 - 5,3 mm
 - For Geberit Silent dB 20: diameter 110mm, wall thickness 6,0 mm
 - For PE-pipes acc. EN 1519-1: diameter 110 mm, wall thickness 4,2 mm
- On one side the pipe may run with zero distance to penetrated wall ($s_3 > 0$ mm).
- One or two collars can be used, depending from possible fire load (refer to 8.6.1.2)

Gap size and gap filler:

- Gap filler: Hilti CFS-FIL
- Annular gap: 5 – 15 mm for one-collar application (collar has not to pass through the wall)
- Annular gap: 15 – 20 mm for two-collar application (collar has to pass through the wall)
- Depth t_{A3} of installed gap filler: over the entire wall thickness t_E
- No backfilling required

With or without acoustic pipe decoupling/insulation: see 7.5.1.12

Requested number of hooks:

Pipe outside nominal diameter d_c (mm)	Number of hooks to be used: <small>(no elbow side - horizontal running pipe / elbow side - vertical running pipe)</small>	
	One collar – one side fire load only	Two collars – potential fire load from both sides
110	4 / 0	4 / 5

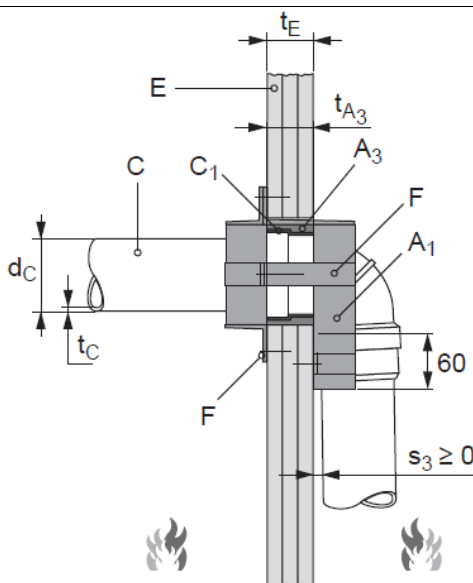

8.6.3.5. A:

Elbow installation with double side potential fire load.

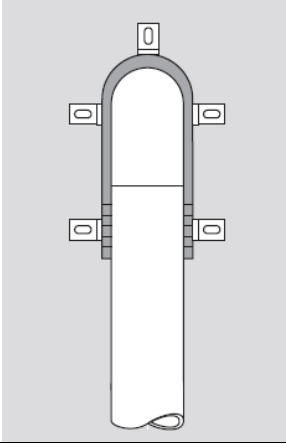
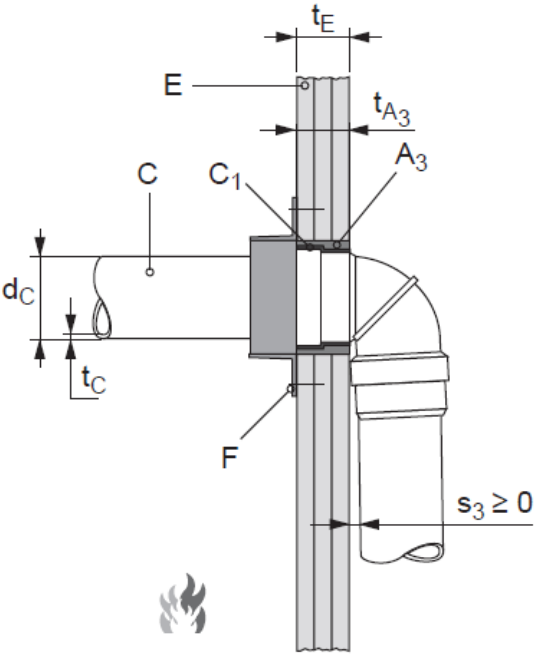
	<p>8.6.3.5 B:</p> <p>Elbow installation with double side potential fire load, seen from elbow side</p>
	<p>8.6.3.5 C:</p> <p>Elbow installation with single side potential fire load.</p>

8.6.3.6 Plastic pipes, with pipe coupling in shaft wall system B (refer to 8.6.1.2), EI 90 - U/U

Situation for EI 90 - U/U:

- Pipe Coupling inside the wall or half in the wall, covered by CFS-C EL collar
- Type of pipes: refer to 8.6.3.1, 8.6.3.2, 8.6.3.3
- Range (dimension) of pipes: refer to 8.6.3.1, 8.6.3.2, 8.6.3.3
- One or two collars can be used, depending from possible fire load, (refer to 8.6.1.2)

Gap size and gap filler:

- Gap filler: Hilti CFS-FIL
- Annular gap: 5 – 15 mm for one-collar application (collar has not to pass through the wall)
- Annular gap: 15 – 20 mm for two-collar application (collar must pass through the wall)
- Depth t_{A3} of installed gap filler: over the entire wall thickness t_E
- No backfilling required

With or without acoustic pipe decoupling/insulation: see 8.6.1.12

Requested number of hooks:

Pipe outside nominal diameter d_c (mm)	Number of hooks to be used: (no elbow side - horizontal running pipe / elbow side - vertical running pipe)	
	One collar – one side fire load only	Two collars – potential fire load from both sides
32	2 / 0	2 / 2
40	3 / 0	3 / 3
50	3 / 0	3 / 3
63	4 / 0	3 / 3
75	4 / 0	3 / 3
90	4 / 0	4 / 4
110	4 / 0	4 / 4

	<p>8.6.3.6 A:</p> <p>Pipe coupling installation with double side potential fire load.</p>
	<p>8.6.3.6 B:</p> <p>Pipe coupling installation with single side potential fire load.</p>
	<p>8.6.3.6 C:</p> <p>Pipe coupling installation with single side potential fire load.</p>

8.6.3.7 **Plastic pipes, pipe to pipe minimum distance in shaft wall system B (refer to 8.6.1.2), EI 90 - U/U**

Situation for EI 90 - U/U:

- Unlimited number of parallel plastic pipes, side by side, distance collar to collar ($s_1 > 0$) mm
- linear arrangement of pipes only, no cluster arrangement
- each single pipe is covered by an individual, uncompleted CFS-C EL collar
- Type of plastic pipes: refer to 8.6.3.1, 8.6.3.2, 8.6.3.3
- Range (dimension) of plastic pipes: refer to 8.6.3.1, 8.6.3.2, 8.6.3.3
- One or two collars can be used, depending from possible fire load (refer to 8.6.1.2)
- Number of plastic pipes in line: unlimited
- With or without acoustic pipe decoupling/insulation: see 8.6.1.12

Pipe and Collar positioning:

- Horizontal linear pipe arrangement mounted directly onto the floor or Vertical linear pipe arrangement mounted directly onto the wall ($s_3 \geq 0$ mm),
- There must be no gap between pipes and collar

Requested number of hooks:

- Always one hook has to be fixed at the end of the collar strip. Place the first hook here.
- If the distance collar to collar s_1 becomes very small a hook can't be installed here. So both ends of the collar strips may be clamped her between adjacent pipes without fixing.
- At the furthest position from firstly placed hook a second hook should be placed. In this position it is recommended to fix two hooks of adjacent pipes with one fixing point.
- every pipe with diameter ($d_c < 63$ mm): 2 hooks
- every pipe with diameter ($63 < d_c < 110$) mm: 3 hooks,
- if 3 hooks should be applied on a pipe, the middle one should be positioned centered between the two outer hooks

Gap size and gap filler:

- Gap filler: Hilti CFS-FIL
- Annular gap: 5 – 15 mm for one-collar application (collar has not to pass through the wall)
- Annular gap: 15 – 20 mm for two-collar application (collar has to pass through the wall)
- Depth t_{A3} of installed gap filler: over the entire wall thickness t_E
- No backfilling required

electronic copy electronic copy electronic copy electronic copy electronic copy electronic copy electronic copy electronic copy electronic copy electronic copy

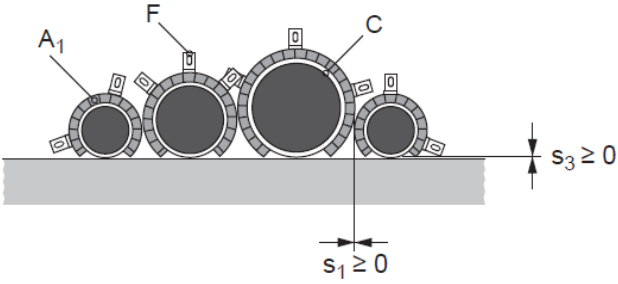
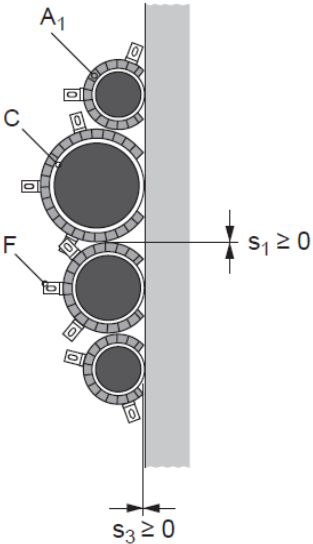
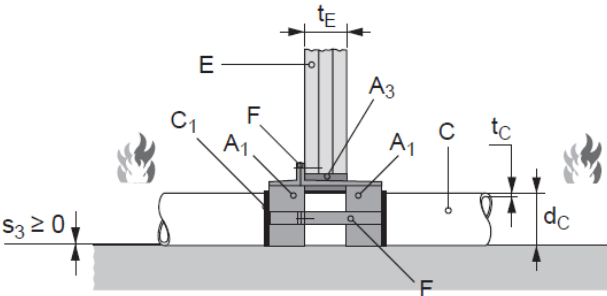
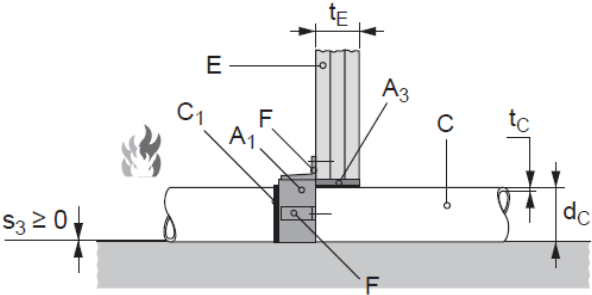
	<p>8.6.3.7 A:</p> <p>Plastic pipes, sealed with individual collars CFS-C EL in direct contact collar to collar (s_1), mounted directly at floor (s_3), penetrating a shaft wall system B</p>
	<p>8.6.3.7 B:</p> <p>Plastic pipes, sealed with individual collars CFS-C EL in direct contact collar to collar (s_1), mounted directly at wall (s_3), penetrating a shaft wall system B</p>
	<p>8.6.3.7 C:</p> <p>Plastic pipes, sealed with individual collars CFS-C EL in direct contact collar to collar (s_1), mounted directly at floor or wall (s_3), penetrating a shaft wall system B. Possible fire access from both sides of the wall.</p>
	<p>8.6.3.7 D:</p> <p>Plastic pipes, sealed with individual collars CFS-C EL in direct contact collar to collar (s_1), mounted directly at floor or wall (s_3), penetrating a shaft wall system B. Possible fire access from one sides of the wall.</p>

8.6.3.8 Aluminum composite pipes, Pipe to pipe minimum distance in shaft wall system B (refer to 8.6.1.2) EI 90- U/C

Situation for EI 90- U/C:

Aluminum Composite pipes:

- Type and dimension of aluminum composite pipes: see table below
- Applicable for single or double side fire access, depending from possible fire load (refer to 8.6.1.2)
- Number of insulated aluminum composite pipes in line: unlimited
- pipe insulation: PE (polyethylene) foam, CS, refer to table below and 8.2.13
- pipe additional protect insulation D_P : Elastomer (for type refer to 8.2.12), thickness $t_{DP} = 9$ mm, $L_I, L_{DP} = 250$ mm on both sides of the wall, Elastomer added on top of PE insulation
- Pipe end configuration: U/C

Aluminum.composite.pipe brand/name	Assessed pipe diameter (mm)	Assessed pipe wall thickness (mm)	Assessed Insulation thickness (mm)
Kelox Ke Kelit	16 – 32	2,0 – 3,0	4 – 13
Uponor Unipipe Plus	16 – 32	2,0 – 3,0	4 – 10
TECE TECEflex	16 – 32	2,75 – 4,0	4 – 13
Geberit Mepla	20	2,5	6 – 13
Geberit Mepla	32	3,0	4 – 13
Rehau Rautitan Stabil	16,2 – 32	2,6 – 4,7	4 – 13

Pipe and Collar positioning:

- Horizontal linear pipe arrangement mounted directly onto the floor or vertical linear pipe arrangement mounted directly onto the wall, ($s_3 \geq 0$) mm
- Parallel, insulated aluminum composite pipes, side by side, distance pipe to pipe ($s_2 \geq 0$) mm
- linear arrangement of pipes only, no cluster arrangement
- There must be no gap between insulated pipes and collar
- All insulated aluminum composite pipes are covered by one uncompleted CFS-C EL collar
- The collar should follow the pipe arrangement outside geometry as much as possible to prevent gaps between the pipes and the collar.
- There is no defined sequence of pipes in line. The firestop installation becomes easier when taking together all aluminum composite pipes.

Requested number of hooks:

- For aluminum composite pipe sealing: always one hook has to be fixed at the furthest end of the collar on both sides. At the point, where two pipes come together a hook should be placed. Number of hooks for parallel aluminum composite pipes with direct contact ($s_2 = 0$ mm), = **(x+1)**, where x = number of all pipes to be covered with one collar.

Gap size and gap filler:

- Gap filler: Hilti CFS-FIL
- Annular gap: 5 – 15 mm for one-collar application (collar has not to pass through the wall)
- Annular gap: 15 – 20 mm for two-collar application (collar has to pass through the wall)
- Depth t_{A3} of installed gap filler: over the entire wall thickness t_E
- No backfilling required

electronic copy electronic copy electronic copy electronic copy electronic copy electronic copy electronic copy electronic copy electronic copy electronic copy

	<p>8.6.3.8 A:</p> <p>Aluminum composite pipes sealed with one open collar CFS-C EL, mounted directly at floor (s_3), penetrating a shaft wall system B</p>
	<p>8.6.3.8 B:</p> <p>Aluminum composite pipes sealed with one open collar CFS-C EL, mounted directly at wall (s_3), penetrating a shaft wall system B</p>
	<p>8.6.3.8 C:</p> <p>Aluminum composite pipes sealed with one open collar CFS-C EL, mounted directly at floor or wall (s_3), penetrating a shaft wall system B. Possible fire access from both sides of the wall.</p>
	<p>8.6.3.8 D:</p> <p>Aluminum composite pipes, sealed with one open collar CFS-C, mounted directly at floor or wall (s_3), penetrating a shaft wall system B. Possible fire access from one sides of the wall only.</p>

8.6.3.9 Plastic pipes with Aluminum composite pipes, pipe to pipe minimum distance in shaft wall system B (refer to 8.6.1.2), EI 90

Situation for EI 90:

Plastic pipes:

- Type of plastic pipes: refer to 8.6.3.1, 8.6.3.2, 8.6.3.3
- Range (dimension) of plastic pipes: refer to 8.6.3.1, 8.6.3.2, 8.6.3.3
- Applicable for single or double side fire access, depending from possible fire load (refer to 8.6.1.2)
- Unlimited number of parallel plastic pipes, side by side, covered by individual collars,
- distance collar to collar ($s_1 \geq 0$) mm
- linear arrangement of pipes only, no cluster arrangement
- mounted directly at floor or wall ($s_3 \geq 0$ mm),
- Number of plastic pipes in line: unlimited
- With or without acoustic pipe decoupling/insulation: see 8.6.1.12
- Pipe end configuration: U/U

Aluminum Composite pipes:

- Type and dimension of aluminum composite pipes: see table below
- Applicable for single or double side fire access, depending from possible fire load (refer to 8.6.1.2)
- Number of insulated aluminum composite pipes in line: unlimited
- pipe insulation: PE (polyethylene) foam, CS,
- pipe additional protect insulation D_P : Elastomer (for type refer to 8.2.12), thickness $t_{DP} = 9$ mm, $L_{DP} = 250$ mm on both sides of the wall
- Pipe end configuration: U/C

Aluminum.composite. pipe brand/name	Assessed pipe diameter (mm)	Assessed pipe wall thickness (mm)	Assessed Insulation thickness (mm)
Kelox Ke Kelit	16 – 32	2,0 – 3,0	4 – 13
Uponor Unipipe Plus	16 – 32	2,0 – 3,0	4 – 10
TECE TECEflex	16 – 32	2,75 – 4,0	4 – 13
Geberit Mepla	20	2,5	6 – 13
Geberit Mepla	32	3,0	4 – 13
Rehau Rautitan Stabil	16,2 – 32	2,6 – 4,7	4 – 13

Pipe and Collar positioning:

- Horizontal linear pipe arrangement mounted directly onto the floor or
- Vertical linear pipe arrangement mounted directly onto the wall
- linear arrangement of pipes only, no cluster arrangement
- There must be no gap between pipes and collar
- The collar should follow the pipe arrangement outside geometry as much as possible to prevent gaps between the pipes and the collar
- There is no defined sequence of pipes in line. The firestop installation becomes easier when taking together all aluminum composite pipes.

Plastic pipes:

- parallel pipes, side by side, distance collar to collar ($s_1 > 0$) mm
- each single plastic pipe is covered by an individual, uncompleted CFS-C EL collar
- If there is a gap between the pipes ($s_2 > 0$ mm), try to put the collar strip in between and cover at first the biggest pipe along the circumference from ground to ground. In a second step proceed in a similar matter with the second biggest pipe. Continue to smallest one.

Aluminum composite pipes:

- Parallel, insulated aluminum composite pipes, side by side, distance pipe to pipe ($s_1 \geq 0$ mm)
- All insulated aluminum composite pipes are covered by one uncompleted CFS-C EL collar

Requested number of hooks:

- For plastic pipe sealing: refer to 8.6.3.7
- For aluminum composite pipe sealing: always one hook has to be fixed at the furthest end of the collar on both sides. At the point, where two pipes come together a hook should be placed. Number of hooks for parallel aluminum composite pipes with direct contact ($s_2 = 0$ mm), = **(x)+1**, where x = number of all pipes to be covered with one open collar,

Gap size and gap filler:

- Gap filler: Hilti CFS-FIL
- Annular gap: 5 – 15 mm for one-collar application (collar has not to pass through the wall)
- Annular gap: 15 – 20 mm for two-collar application (collar has to pass through the wall)
- Depth t_{A3} of installed gap filler: over the entire wall thickness t_E
- No backfilling required

electronic copy electronic copy electronic copy electronic copy electronic copy electronic copy electronic copy electronic copy electronic copy electronic copy

	<p>8.6.3.9 A:</p> <p>Plastic pipes (C) and Aluminum composite pipes (ACP) in minimum distance to each other, mounted directly onto the floor (E), penetrating a shaft wall system B</p>
	<p>8.6.3.9 B:</p> <p>Plastic pipes (C) and Aluminum composite pipes (ACP) in minimum distance to each other, mounted directly onto a wall (E), penetrating a shaft wall system B</p>

8.6.3.10 Aluminum composite pipes with electric conduits, pipe to conduit in minimum distance in shaft wall system B (refer to 8.6.1.2), EI 90

Situation for EI 90:

Aluminum Composite pipes:

- Type and dimension of insulated aluminum composite pipes used: see table below
- Applicable for single or double side fire access, depending from possible fire load (refer to 8.6.1.2)
- Number of insulated aluminum composite pipes in line: unlimited
- mounted directly at floor or wall ($s_3 \geq 0$ mm),
- pipe insulation: PE (polyethylene) foam, CS,
- Parallel, insulated aluminum composite pipes, side by side, distance pipe to pipe ($s_2 \geq 0$ mm)
- linear arrangement of pipes only, no cluster arrangement
- pipe additional protect insulation D_P : Elastomer (for type refer to 8.2.12), thickness $t_{DP} = 9$ mm, LI, $L_{DP} = 250$ mm on both sides of the wall
- Pipe end configuration: U/C

Aluminum.composite. pipe brand/name	Assessed pipe diameter (mm)	Assessed pipe wall thickness (mm)	Assessed Insulation thickness (mm)
Kelox Ke Kelit	16 – 32	2,0 – 3,0	4 – 13
Uponor Unipipe Plus	16 – 32	2,0 – 3,0	4 – 10
TECE TECEflex	16 – 32	2,75 – 4,0	4 – 13
Geberit Mepla	20	2,5	6 – 13
Geberit Mepla	32	3,0	4 – 13
Rehau Rautitan Stabil	16,2 – 32	2,6 – 4,7	4 – 13

Plastic conduits:

- Type of plastic conduits RC: all rigid, flexible, and pliable conduits
- Dimension of plastic conduits RC: max. 40 mm diameter
- Applicable for single or double side fire access, depending from possible fire load (refer to 8.6.1.2)
- Empty conduits or filled with cables R, projecting length $L_{RC} \geq 600$ mm on each side of the wall
- mounted directly at floor or wall ($s_3 \geq 0$ mm),
- Parallel, insulated plastic, side by side, distance pipe to pipe ($s_2 \geq 0$ mm)
- linear arrangement of pipes only, no cluster arrangement
- Number of parallel plastic conduits in line: max. 2
- With insulation D_{DP} : mineral wool, thickness $t_{DP} = 20$ mm, LI, length L_{DP} : 250 mm on each side
- conduit end configuration: U/U
- usable cables R: filled with all sizes of common cables, max. single cable diameter is 28 mm, including optical fibre cables

Pipe/Conduit and Collar positioning:

- Horizontal linear pipe arrangement mounted directly onto the floor or
- Vertical linear pipe arrangement mounted directly onto the wall
- linear arrangement of pipes/conduits only, no cluster arrangement
- There must be no gap between pipes/conduits and collar
- The collar should follow the pipe/conduit arrangement outside geometry as much as possible to prevent gaps between the pipes and the collar
- There is no defined sequence of pipes/conduits in line. The firestop installation becomes easier when taking together all penetrating aluminum composite pipes and conduits, so all pipes together may be covered by one common collar.

- If there is a gap between the conduits ($s_2 > 0$ mm), try to put the collar strip in between and cover at first the biggest conduit along the circumference from ground to ground. In a second step proceed in a similar matter with the second conduit.

Requested number of hooks:

- For parallel aluminum composite pipes and plastic conduit sealing (mixed seal) in direct contact ($s_2 = 0$) one collar covers it all together. Always one hook has to be fixed at the furthest end of the collar on both sides. At the point, where two pipes/conduits come together another hook should be placed. Number of hooks for parallel aluminum composite pipes and conduits with direct contact ($s_2 = 0$ mm), = **(x)+1**, where x = number of all pipes and conduits to be covered with one collar,
- For parallel aluminum composite pipes and plastic conduit sealing (mixed seal) not in direct contact ($s_2 > 0$) more than one collar have to be used.

Gap size and gap filler:

- Gap filler: Hilti CFS-FIL
- Annular gap: 5 – 15 mm for one-collar application (collar has not to pass through the wall)
- Annular gap: 15 – 20 mm for two-collar application (collar has to pass through the wall)
- Depth t_{A3} of installed gap filler: over the entire wall thickness t_E
- No backfilling required

electronic copy electronic copy electronic copy electronic copy electronic copy electronic copy electronic copy electronic copy electronic copy electronic copy

	<p>8.6.3.10 A:</p> <p>Parallel plastic conduits (RC) in zero distance to isolated Aluminum composite pipes (ACP), mounted directly onto the floor (E), penetrating a shaft wall system B.</p>
	<p>8.6.3.10 B:</p> <p>Parallel plastic conduits (RC) in zero distance to isolated Aluminum composite pipes (ACP), mounted directly onto a wall (E), penetrating a shaft wall system B.</p>
	<p>8.6.3.10.C:</p> <p>Parallel plastic conduits (RC) mounted directly onto the floor (E), penetrating a shaft wall system B. Conduits have to be in projecting length</p>
	<p>8.6.3.10 D:</p> <p>Parallel plastic conduits (RC) in zero distance to isolated Aluminum composite pipes (ACP), mounted directly onto the floor, penetrating a shaft wall system B.</p>

8.6.3.11 Aluminum composite pipes with electric conduits and plastic pipes in minimum distance in shaft wall system B (refer to 8.6.1.2), EI 90

Situation for EI 90:

- Sealed Plastic together pipes with sealed Aluminum composite pipes and cable conduits in minimum distance ($s_2 \geq 0$) mm, mounted directly onto a floor or onto a wall, penetrating a shaft wall system B.

Plastic pipes:

- Type of plastic pipes: refer to 8.6.3.1, 8.6.3.2, 8.6.3.3
- Range (dimension) of plastic pipes: refer to 8.6.3.1, 8.6.3.2, 8.6.3.3
- Applicable for single or double side fire access, depending from possible fire load (refer to 8.6.1.2)
- Unlimited number of parallel plastic pipes, side by side, covered by individual collars,
- distance collar to collar ($s_1 \geq 0$) mm
- linear arrangement of pipes only, no cluster arrangement
- mounted directly at floor or wall ($s_3 \geq 0$ mm),
- Number of plastic pipes in line: unlimited
- With or without acoustic pipe decoupling/insulation: see 8.6.1.12
- Pipe end configuration: U/U

Aluminum Composite pipes:

- Type and dimension of insulated aluminum composite pipes used: see table below
- Applicable for single or double side fire access, depending from possible fire load (refer to 8.6.1.2)
- Number of insulated aluminum composite pipes in line: unlimited
- Horizontal linear pipe arrangement mounted directly onto the floor or vertical linear pipe arrangement mounted directly onto the wall ($s_3 \geq 0$ mm),
- pipe insulation: PE (polyethylene) foam, CS,
- Parallel, insulated aluminum composite pipes, side by side, distance pipe to pipe ($s_2 \geq 0$ mm)
- linear arrangement of pipes only, no cluster arrangement
- pipe additional protect insulation D_P : Elastomer (for type refer to 8.2.12), thickness $t_{DP} = 9$ mm, $L_I, L_{DP} = 250$ mm on both sides of the wall
- Pipe end configuration: U/C

Aluminum.composite. pipe brand/name	Assessed pipe diameter (mm)	Assessed pipe wall thickness (mm)	Assessed Insulation thickness (mm)
Kelox Ke Kelit	16 – 32	2,0 – 3,0	4 – 13
Uponor Unipipe Plus	16 – 32	2,0 – 3,0	4 – 10
TECE TECEflex	16 – 32	2,75 – 4,0	4 – 13
Geberit Mepla	20	2,5	6 – 13
Geberit Mepla	32	3,0	4 – 13
Rehau Rautitan Stabil	16,2 – 32	2,6 – 4,7	4 – 13

Plastic conduits:

- Type of plastic conduits RC: all rigid, flexible and pliable conduits,
- Dimension of plastic conduits d_{RC} : max. 40 mm diameter
- Applicable for single or double side fire access, depending from possible fire load (refer to 8.6.1.2)
- Empty conduits or filled with cables R, projecting length $L_{RC} \geq 600$ mm on each side of the wall
- mounted directly at floor or wall ($s_3 \geq 0$ mm),
- Parallel, insulated plastic, side by side, distance pipe to pipe ($s_2 \geq 0$ mm)
- linear arrangement of pipes only, no cluster arrangement

electronic copy

- Number of parallel plastic conduits in line: max. 2
- With insulation D_{DP} : mineral wool, thickness $t_{DP} = 20$ mm, LI, length L_{DP} : 250 mm on each side
- conduit end configuration: U/U
- usable cables R: filled with all sizes of common cables, max. single cable diameter is 28 mm, including optical fibre cables

Pipe/Conduit and Collar positioning:

Plastic conduits:

- Max. two single plastic conduits (with or without cables) are covered by one uncompleted CFS-C EL collar
- If there is a gap between the conduits ($s_2 > 0$ mm), try to put the collar strip in between and cover at first the biggest conduit along the circumference from ground to ground. In a second step proceed in a similar matter with the second conduit.

Plastic pipes:

- Refer to 8.6.3.7

Aluminum composite pipes:

- All insulated aluminum composite pipes in zero distance are covered by one uncompleted CFS-C EL collar
- There must be no gap between pipes/conduits and collar
- The collar should follow the pipe/conduit arrangement outside geometry as much as possible to prevent gaps between the pipes and the collar
- There is no defined sequence of pipes/conduits in line. The firestop installation becomes easier when taking together all penetrating aluminum composite pipes and conduits, so all pipes together may be covered by one common collar.

Requested number of hooks:

- For parallel aluminum composite pipes and plastic conduit sealing (mixed seal) in direct contact ($s_2 = 0$) one collar covers it all together. Always one hook must be fixed at the furthest end of the collar on both sides. At the point, where two pipes/conduits come together another hook should be placed. Number of hooks for parallel aluminum composite pipes and conduits with direct contact ($s_2 = 0$ mm), = **(x)+1**, where x = number of all pipes and conduits to be covered with one collar,
- For parallel aluminum composite pipes and plastic conduit sealing (mixed seal) not in direct contact ($s_2 > 0$) more than one collar have to be used.
- Plastic pipes have to be sealed individually, refer to 8.6.3.7

Gap size and gap filler:

- Gap filler: Hilti CFS-FIL
- Annular gap: 5 – 15 mm for one-collar application (collar has not to pass through the wall)
- Annular gap: 15 – 20 mm for two-collar application (collar has to pass through the wall)
- Depth t_{A3} of installed gap filler: over the entire wall thickness t_E
- No backfilling required

electronic copy electronic copy electronic copy electronic copy electronic copy electronic copy electronic copy electronic copy electronic copy electronic copy

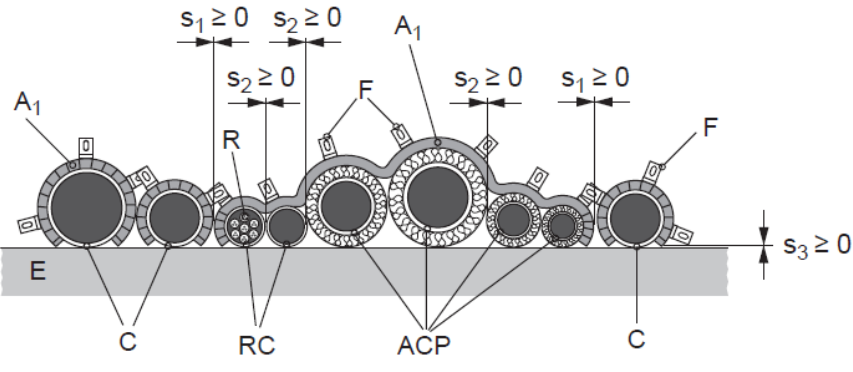
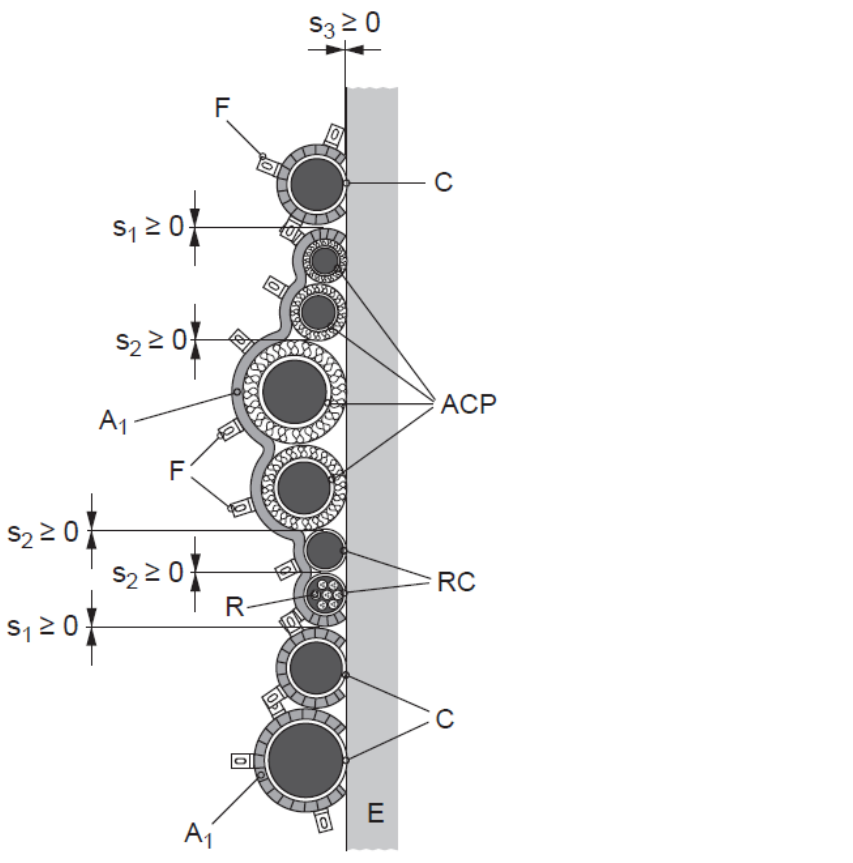
	<p>8.6.3.11 A:</p> <p>Aluminum composite pipes with electric conduits and plastic pipes in minimum distance, mounted directly onto a floor (E), penetrating a shaft wall system B.</p>
	<p>8.6.3.11 B:</p> <p>Aluminum composite pipes with electric conduits and plastic pipes in minimum distance, mounted directly onto the wall (E), penetrating a shaft wall system B</p>

8.6.3.12 Electric cables, conduits and bunched cables in shaft wall system B (refer to 8.6.1.2), EI 90

Hilti Firestop mastic Filler CFS-FIL is an ancillary product to the endless collar CFS-C EL, refer to Annex 2, chapter 6.2.5 of this ETA.

CFS-FIL is even an essential component of Hilti Firestop Block CFS-BL, described in detail in ETA -13/0099.

Situation for EI 90:

- Applicable identical for single or double side fire access, depending from possible fire load (refer to 8.6.1.2).

Single Cables (R):

- All cable types currently used up to 21 mm single cable diameter
- Optical fibre cables
- No waveguides, no non-sheathed cables
- Mineral wool insulation, thickness 20 mm, LI, length: 250 mm on both sides
- With insulation D_{DP} : mineral wool, thickness $t_{DP} = 20$ mm, LI, length L_{DP} : 250 mm on each side

Single cables bundles (RB):

- Max. diameter of tied cable bundle: 50 mm
- All cable types currently used up to 21 mm single cable diameter, including optical fibre cables
- With insulation D_{DP} : mineral wool, thickness $t_{DP} = 20$ mm, LI, length L_{DP} : 250 mm on each side

Plastic conduits (RC):

- Type of plastic conduits: all rigid, flexible and pliable conduits
- Dimension of plastic conduits: max. 40 mm diameter
- Empty conduit or filled with cable
- conduit end configuration: U/U
- usable cables: filled with all sizes of common cables, max. single cable diameter is 28 mm, including optical fiber cables,
- With or without mineral wool protect insulation

Opening and Gap size, gap filler:

- Aperture size in shaft wall for single cables, single cable bundles, plastic conduits and combination of small cable bundles: max. diameter 111 mm
- Gap filler: Hilti CFS-FIL
- Annular gap width: ($0 \leq s_3 \leq 50$ mm)
- Depth t_{A3} of installed gap filler: over the entire wall thickness t_E
- No backfilling required

electronic copy electronic copy electronic copy electronic copy electronic copy electronic copy electronic copy electronic copy electronic copy electronic copy

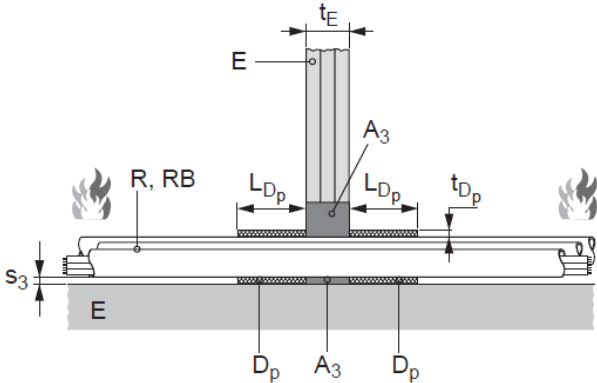
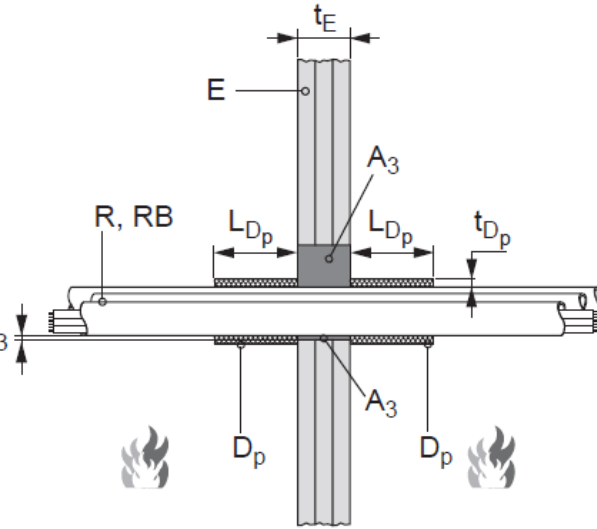
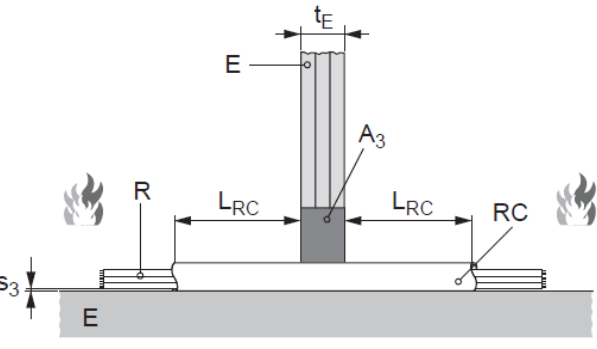
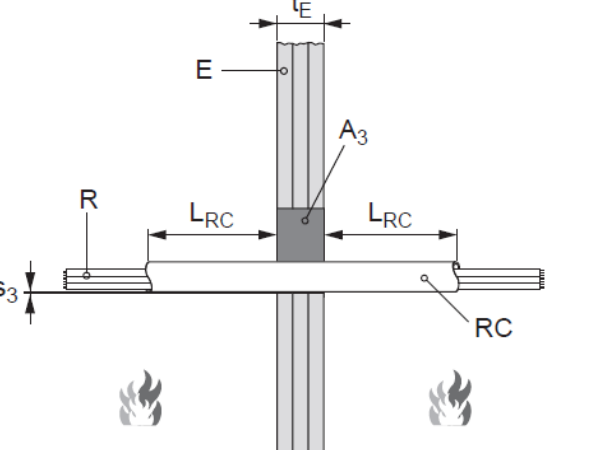
	<p>8.6.3.12 A:</p> <p>Single (R) or bunched (RB) cables, partly isolated with a mineral wool protect insulation D_p, penetrating a shaft wall system B with single or double-side fire load, mounted directly onto a floor E</p>
	<p>8.6.3.12 B:</p> <p>Single (R) or bunched (RB) cables, partly isolated with a mineral wool protect insulation D_p, penetrating a shaft wall system B with single or double-side fire load, mounted into the shaft wall</p>
	<p>8.6.3.12 C:</p> <p>Cable conduits RC (empty or filled with cables R), mounted directly onto a floor E, with single or double-side fire load</p>
	<p>8.6.3.12 D:</p> <p>Cable conduits RC (empty or filled with cables R), mounted directly onto a floor E, with single or double-side fire load</p>

9 ANNEX 4: ABBREVIATIONS AND REFERENCE DOCUMENTS

Abbreviations used in drawings

Abbreviation	Description
A ₁	Hilti Firestop Collar Endless CFS-C EL
A ₁₀	Hilti Firestop Collar Endless CFS-C EL with oddment
A ₂	Annular gap seal with Hilti Firestop Acrylic Sealant CFS-S ACR
A ₃	Annular gap seal with Hilti CFS-FIL
A ₄	Annular gap seal with gypsum plaster
A ₅	Annular gap seal with cementitious mortar acc. EN 998-2, group M10
A ₆	Hilti Firestop Bandage CFS-B
ACP	Aluminum Composite Pipe
B	Backfilling material (mineral wool)
C	Plastic Pipe
C ₁	Sound decoupling insulation
CLT	Cross Laminated Timber – specific wooden floor and wall set-up
D	Pipe insulation
D _W	Pipe insulation, incombustible, based on mineral wool
D _E	Pipe insulation, combustibile, based on elastomeric foamed material
D _P	Pipe insulation - Protect insulation
D _{PE}	Pipe insulation, combustibile, based on polyethylene foam
d _A	Aperture diameter in supporting construction E
d _C	Pipe diameter (nominal outside diameter) for plastic pipes
d _M	Pipe diameter (nominal outside diameter) for metal pipes
d _{ACP}	Pipe diameter (nominal outside diameter) for Aluminum composite pipes
d _{RC}	Pipe diameter (nominal outside diameter) for Cable conduits
E	Building element (wall, floor)
E ₁	Aperture framing / beading / additional framing
F	Hooks (long or short) for fixing of the collar
h	Height
h _{E1}	Height of aperture framing / beading / additional framing
L	Length
L _D	Length of Insulation
L _{DP}	Length of Protect Insulation
L _{RC}	Projecting Length for electric conduits, filled or unfilled
n	amount, number of pieces
M	Metal pipe
PG	Pipe group
R	Electric Cables, optical cables
RC	Conduit for electric/optical cables
RB	Bundle of electric/optical cables
RS	Cable support system

S ₁	Minimum distance between single penetration seals
S ₂	Minimum distance between clustered pipe or other penetrants within one penetration
S ₃	Minimum distance between penetrating pipe and building element
t _A	Total seal thickness
t _{A2}	Thickness of Hilti Firestop Acrylic Sealant CFS-S ACR
t _{A3}	Thickness of Hilti CFS-FIL
t _{ACP}	Aluminum composite pipe wall thickness
t _C	Plastic Pipe wall thickness
t _{C1}	Thickness of acoustic sound decoupling insulation
t _D	Insulation thickness
t _E	Thickness of the building element
t _I	Thickness of individual layer thickness within wooden constructions
t _{DP}	Thickness of Additional Protect Insulation
t _M	Metal Pipe wall thickness
t _{RC}	Wall thickness / Wave high for electric conduits
V	Sleeve
w	Width
w _{E1}	Width of aperture framing / beading / additional framing
ρ _E	Density of the building element

10 ANNEX 5: INSTRUCTION FOR USE

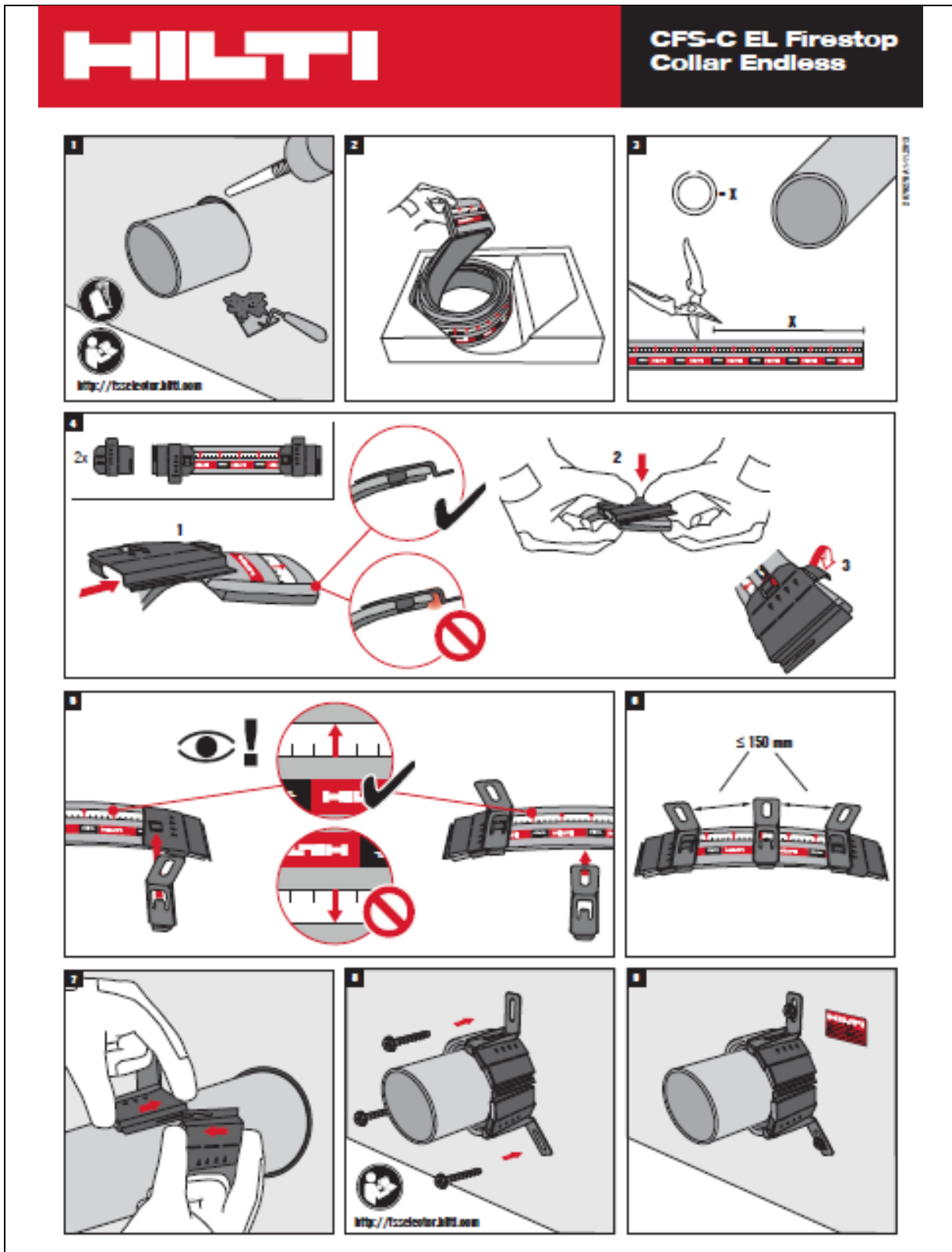

HILTI

**CFS-C EL Firestop
 Collar Endless**

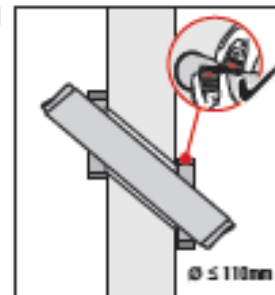
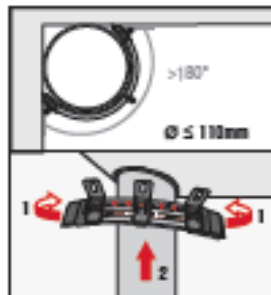
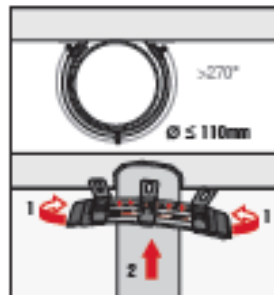
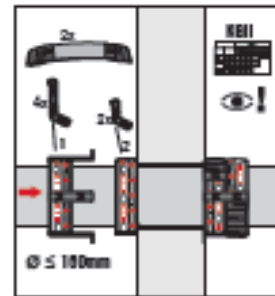
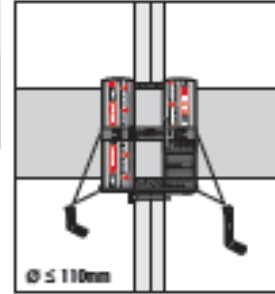
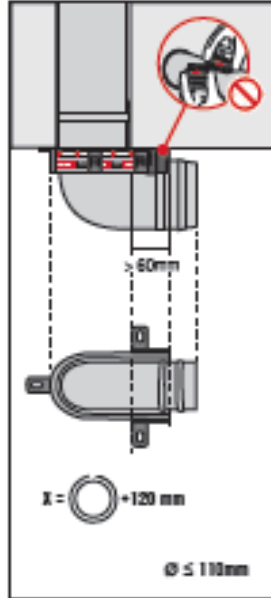
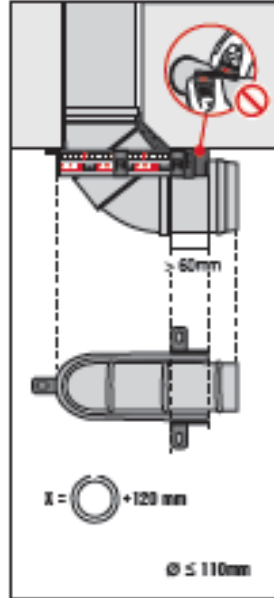
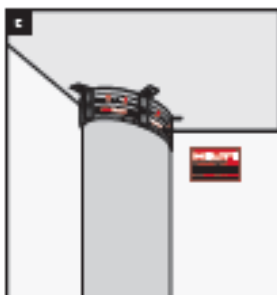
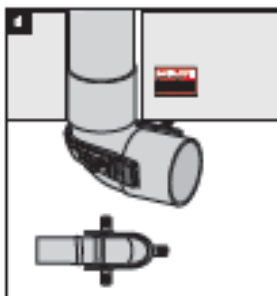
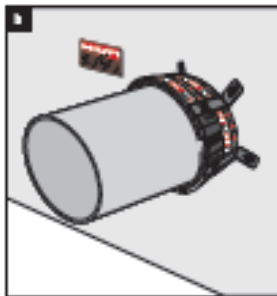
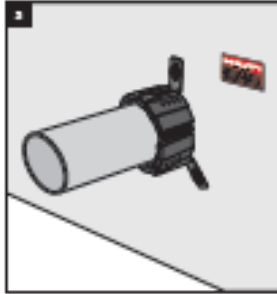

= X		mm	4 mm	6 mm	13 mm	25 mm
			GFS G-EL mm	GFS G-EL mm	GFS G-EL mm	GFS G-EL mm
$\varnothing \le 125\text{mm}$ 	2x	18	130	130	155	180
		32	150	175	205	230
		40	175	200	230	260
	3x	60	205	230	265	
		68	225	250	285	
		63	250	275	305	
$125 \le \varnothing \le 160\text{mm}$ 	4x	110	395	420	450	
	KBI = 2x 4x	126	445	470	500	
		136	475	500	530	
		140	490	515	545	
		160	555	580	610	