



# HILTI FIRESTOP MORTAR CFS-M RG

European Technical Approval  
ETA N° 12/0101



# HILTI FIRESTOP MORTAR CFS-M RG



## APPLICATIONS

- Mixed penetrations in rigid walls and floors from 150 mm
- Cables, cable bundles, cable trays and cable conduits
- Non-combustible (metal) pipes with non-combustible insulation
- Non-combustible (metal) and composite pipes with combustible insulation in combination with firestop bandage CFS-B
- Combustible (PVC-U and PE) pipes in combination with firestop collar CFS-C, firestop collar CFS-C P or firestop wrap CFS-W

## ADVANTAGES

- Easier to install-consistency can be varied for application with a trowel or commercially available pumps
- Excellent thermal insulating properties
- Minimal shrinkage during curing and no spalling in the event of fire
- Paintable

The European Technical Assessment (ETA) and the technical data sheet can be obtained via your local Hilti contact.

## Technical Data

<b>Mix ratio (Mortar to Water by Weight)</b>	2.5:1
<b>Max. compressive strength after 28 days</b>	2.9 N/mm <sup>2</sup>
<b>Working time</b>	45 min
<b>Shelf life (@73°F/23°C and 50% relative humidity)</b>	12 month(s)
<b>Application temperature</b>	5°C to 30°C
<b>Temperature resistance</b>	-10°C to +80°C
<b>Storage temperature</b>	5°C to 30°C
<b>Approvals</b>	ETA 12/0101
<b>Base materials</b>	Concrete, aerated concrete and masonry
<b>Reaction to fire class</b>	Class A1 according to EN 13501-1

Order designation	Sales quantity	Item number
Firestop mortar CFS-M RG	1 PC	02018780

# INSTALLATION INSTRUCTIONS

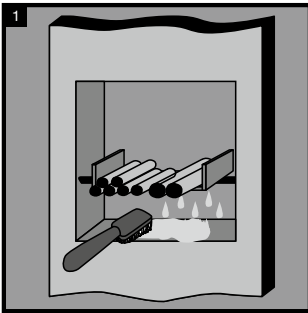

Clean and pre-moisten surfaces. Cables and supporting structures must be dry and clean of dust, grease or oil and installed in compliance with local building and electrical standards.

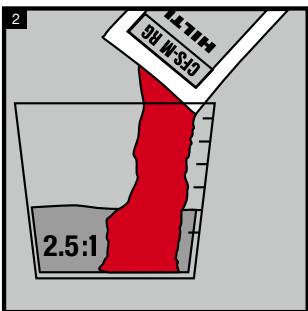

Add Hilti Firestop Mortar CFS-M RG to water in a ratio of approximately 2.5 : 1 (mortar to water by weight). The mix ratio of Hilti Firestop Mortar to water determines the desired consistency (stiffness).

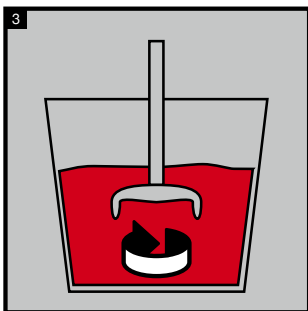

Stir the mixture thoroughly with, for example, a Hilti TE-MP paddle. Large volumes of Hilti Firestop Mortar may be mixed using commercially available mixing or plastering machines.  
Do not use any other binders or additives.

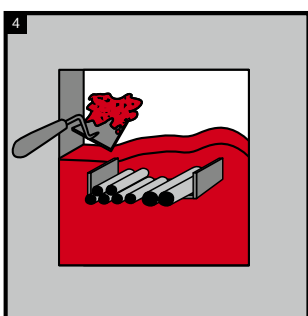

Place forms on one or both sides of large openings. Floor openings must have formwork underneath. Apply mixed mortar in the opening using a trowel or pump and compact it. Ensure that all gaps and spaces are completely filled and closed. Smooth the surface as with standard concrete.

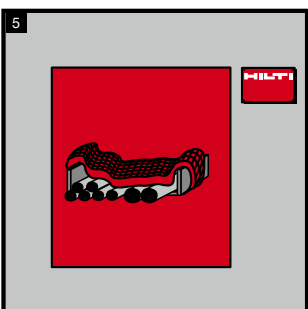

Depending on the application and fire rating to be achieved, additional protection (e.g. mineral wool mat) may be required (see ETA for details).  
For installation of additional components (e.g. Hilti Firestop Collar CFS-C P and Hilti Firestop Bandage CFS-B) see ETA.  
If required by national prescriptions mark the penetration seal with an identification plate containing the required information. In such a case fasten the identification plate in a visible position next to the seal.

# CABLE PENETRATION, PIPE PENETRATION

## RIGID WALL

The intended use of Hilti firestop mortar CFS-M RG is to reinstate the fire resistance of:

Rigid walls (E), minimum thickness 150 or 175 mm ( $t_E$ ), concrete, aerated concrete or masonry, minimum density of 550 or 1100 kg/m<sup>3</sup>. All penetrating items (cables, cable trays, conduits, metal pipes and plastic pipes) can be installed as a single, multiple or mixed configuration. Maximum seal size (width × height) 1200 mm × 2000 mm respectively 1000 mm × 1500 mm depending on wall thickness. Minimum distances between penetrants and seal edges to be considered.

## CABLES, CABLE BUNDLES, CABLE TRAYS AND CONDUITS

### Additional protection

Depending on the required fire resistance, additional protection (AP) may be required.

AP: mineral wool mat, wrapped around cables/cable support (trays, ladders), Al-faced side outside, fixed with wire, width (length along the cables  $L_{AP}$ ) 200 mm, thickness ( $t_{AP}$ ) 30 mm.

Penetration seal (A)/services (C)	Wall type and thickness ( $t_E$ )	Classification E = Integrity I = Insulation		Other criteria, description
		Without additional protection (AP)	With additional protection (AP)	
All sheathed cables up to 21 mm diameter	Rigid Wall $\geq$ 150 mm minimum density of 550 kg/m <sup>3</sup>	EI 120	EI 120	
All sheathed cables from 21 mm to 80 mm diameter		EI 90	EI 120	
All non-sheathed cables max. diameter 24 mm		EI 30	EI 120	
Tied cable bundle max. diameter 100 mm with max. diameter of single cable 21 mm		EI 120	EI 120	
Plastic conduits and tubes $\leq$ 16 mm with or without cables or cable supports		EI 180-U/C		In case a conduit is installed with open ends on both sides (U/U), conduit must be closed with e.g. Hilti Firestop Acrylic Sealant CFS-S ACR.
Steel conduits and tubes $\leq$ 16 mm with or without cables or cable supports		EI 180-C/U		

**Rigid wall type A according to clause 1.2.1 of the ETA (density  $\geq 500 \text{ kg/m}^3$ , minimum thickness 150 mm)**

**Penetration seal**

Hilti Firestop Mortar CFS-M RG (A<sub>1</sub>), thickness ( $t_{A1}$ )  $\geq 150 \text{ mm}$  (opening depth  $t_E$  filled completely).

Maximum distance to first service support construction: 260 mm subject to deviating values given in the tables below.

Maximum seal size:  $w \times h = 1200 \times 2000 \text{ mm}$

Minimum distances in mm (see illustration below):

$s_1 = 0$  (distance between cables/cable supports and seal edge)

$s_2 = 0$  (distance between cable supports)

$s_3 = 0$  (distance between cables and upper seal edge)

$s_4 = 0$  (distance between cable supports and bottom seal edge)

$s_5 = 120 \text{ mm}$

$s_6 = 0$  (distance between metal pipes and seal edge)

$s_7 = 0$  (distance between metal pipes) in case of mineral wool insulation and linear arrangement; in case of cluster arrangement  $s_7 = 100 \text{ mm}$

$s_8 = 10$  (distance between metal pipes) in case of Armaflex insulation and linear arrangement; in case of cluster arrangement  $s_8 = 100 \text{ mm}$

$s_9 = 117$  (distance between plastic pipes/pipe closure devices and seal edge)

$s_{11} = 0$  (distance between plastic pipes/pipe closure devices) in case of Hilti Firestop Collar CFS-C P and linear arrangement; in case of cluster arrangement  $s_{11} = 100 \text{ mm}$

$s_{11} = 50$  (distance between plastic pipes/pipe closure devices) in case of Hilti Firestop Collar CFS-C and linear arrangement; in case of cluster arrangement  $s_{11} = 100 \text{ mm}$

$s_{12} = 0$  (distance between metal pipes and plastic pipes/pipe closure devices)

$s_{13} = 0$  (distance between cables/cable supports and metal pipes)

$s_{14} = 0$  (distance between cables/cable supports and plastic pipes/pipe closure devices)

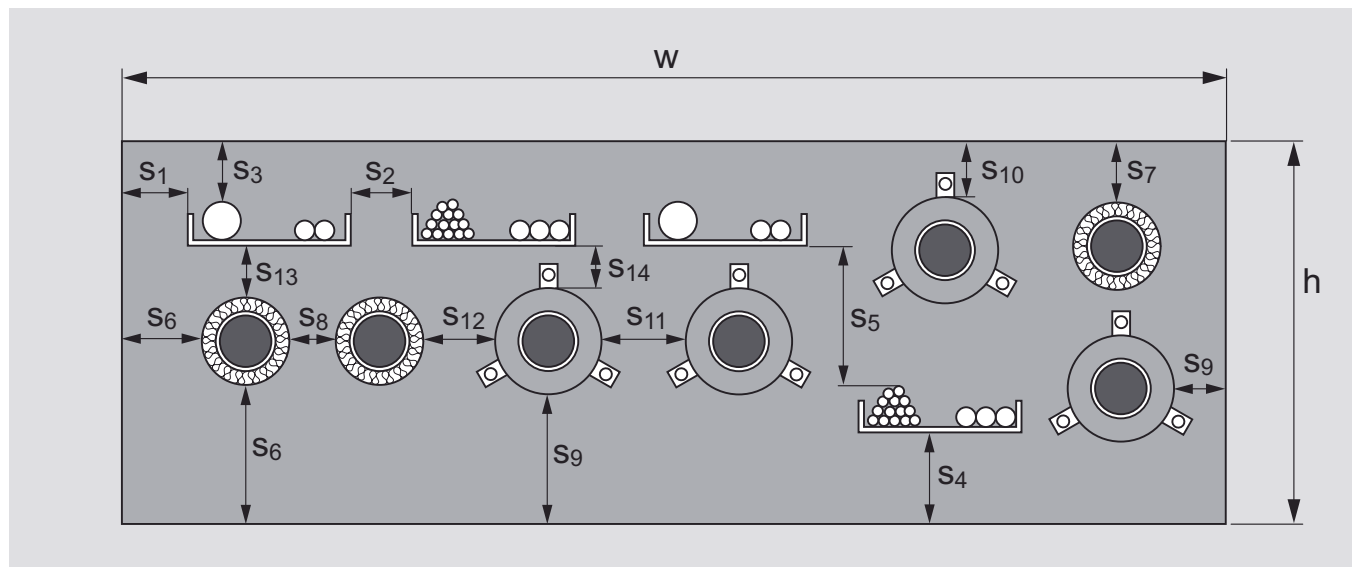

## Cable penetrations without add. protection

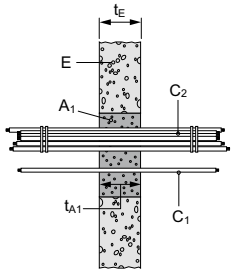
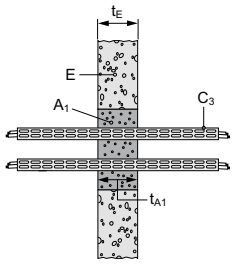

## Cable penetrations with additional protection (AP)

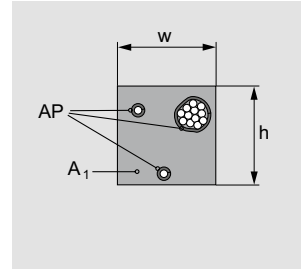
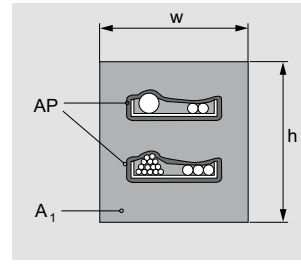
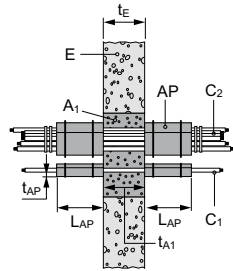
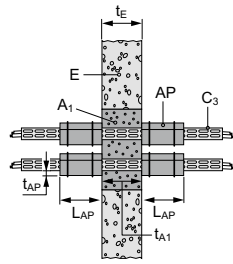

Abbreviation	Description
A <sub>1</sub>	Hilti Firestop Mortar CFS-M RG according to Annex B.1 of the ETA
A <sub>2</sub>	Hilti Firestop Bandage CFS-B according to Annex B.6 of the ETA
A <sub>3</sub>	Hilti Firestop Collar CFS-C P or CFS-C according to Annex B.2 and B.3 of the ETA
A <sub>4</sub>	Hilti Firestop Wrap CFS-W according to Annex B.5 of the ETA
A <sub>P</sub>	Additional protection according to clause 1.1.2 of the ETA
C, C <sub>1</sub> , C <sub>2</sub> , C <sub>3</sub>	Penetrating Elements
D	Pipe insulation
d <sub>A</sub>	Overlap of mortar (seal type 2)
d <sub>c</sub>	Pipe diameter
E	Building element (wall, floor)
h	Height of penetration seal
l	Length of the penetration seal
L <sub>D</sub>	Length of local pipe insulation
L <sub>AP</sub>	Length of the additional protection AP
s <sub>1</sub> to s <sub>14</sub>	Distances
t <sub>A1</sub>	Thickness of the mortar seal
t <sub>AP</sub>	Thickness of the additional protection AP
t <sub>c</sub>	Wall thickness of the pipe
t <sub>D</sub>	Thickness of the pipe insulation
t <sub>E</sub>	Thickness of the building element (wall, floor)
w	Width of penetration seal

## METAL PIPES WITH MINERAL WOOL INSULATION

Steel, cast iron, stainless steel, Ni alloys (NiCu, NiCr and NiMo alloys) and copper pipes.

Penetration seal (A)/services (C)	Wall type and thickness ( $t_e$ )	Insulation thickness ( $t_b$ )	Classification E = Integrity I = Insulation	Other criteria, description
Steel pipes 26.7 – 76.0 mm diameter, pipe wall thickness 2.2/2.9 – 14.2 mm	Rigid Wall $\geq 150$ mm minimum density of 550 kg/m <sup>3</sup>	$\geq 20$ mm	EI 120-C/U	With continued insulation (D), sustained
Steel pipes 76.0 – 168.3 mm diameter, pipe wall thickness 2.9/3.6 – 14.2 mm		$\geq 40$ mm		
Steel pipes 26.7 – 76.0 mm diameter, pipe wall thickness 2.2/2.9 – 14.2 mm		20 mm	EI 120-C/U	
Steel pipes 76.0 mm diameter, pipe wall thickness 2.9 – 14.2 mm		40 mm		With local insulation (D), LD $\geq 500$ mm, sustained
Steel pipes 76.0 – 168.3 mm diameter, pipe wall thickness 2.9/3.6 – 14.2 mm		40 mm	EI 90-C/U	
Steel pipes 114.3 mm diameter, pipe wall thickness 3.7 – 14.2 mm		$\geq 40$ mm	EI 120-C/U	With continued insulation (D), interrupted
Steel pipes 114.3 mm diameter, pipe wall thickness 3.7 – 14.2 mm		40 mm	EI 120-C/U	With local insulation (D), LD $\geq 800$ mm, interrupted
Copper pipes 28 – 54 mm diameter, pipe wall thickness 1.0/1.5 – 14.2 mm		$\geq 20$ mm		
Copper pipes 54 – 89 mm diameter, pipe wall thickness 1.5/2.0 – 14.2 mm		$\geq 40$ mm	EI 120-C/U	With continued insulation (D), sustained
Copper pipes 28 – 54 mm diameter, pipe wall thickness 1.0/1.5 – 14.2 mm		20 mm		
Copper pipes 54 mm diameter, pipe wall thickness 1.5 – 14.2 mm	40 mm	EI 120-C/U	With local insulation (D), LD $\geq 500$ mm, sustained	
Copper pipes 54 – 89 mm diameter, pipe wall thickness 1.5/2.0 – 14.2 mm	40 mm		With local insulation (D), LD $\geq 800$ mm, sustained	

### Continued insulation, sustained

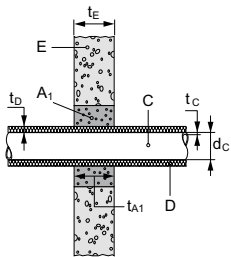

### Local insulation, sustained

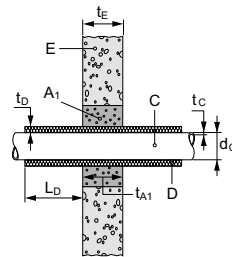

### Continued insulation, interrupted

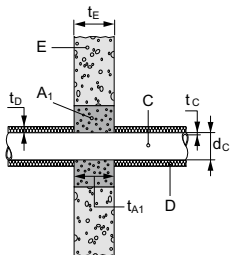

### Local insulation, interrupted

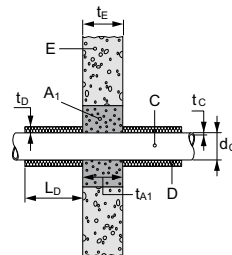

## SPECIFICATION FOR MINERAL WOOL PRODUCTS SUITABLE FOR BEING USED AS PIPE INSULATION

---

### Interrupted insulation

---

Stone wool according to EN 14303, class A2 or A1 according to EN 13501-1, Al-faced

---

### Sustained insulation

---

Manufacturer	Product designation
Isover	Coquilla AT-LR
Isover	Protect 1000 S alu
Isover	Protect BSR 90 alu
Paroc	Section AluCoat T
Rockwool	Conlit Pipe sections
Rockwool	Klimarock
Rockwool	RS 800 pipe sections

---



## METAL PIPES WITH FLEXIBLE ELASTOMETRIC FOAM INSULATION

Steel, cast iron, stainless steel, Ni alloys (NiCu, NiCr and NiMo alloys) and copper pipes.

With Hilti firestop bandage CFS-B (A<sub>2</sub>), two layers wrapped around pipe insulation on each side of the seal.

Penetration seal (A)/ services (C)	Wall type and thickness (t <sub>w</sub> )	Insulation thickness (t <sub>i</sub> )	Classification E = Integrity I = Insulation	Other criteria, description
Metal pipes, 26.7 – 76.0 mm diameter, pipe wall thickness 2.2/2.9 – 14.2 mm	Rigid Wall ≥ 150 mm minimum density of 550 kg/m <sup>3</sup>	19/19 – 41 mm	EI 120-C/U	With continued insulation (D), sustained
Metal pipes, 76.0 – 168.3 mm diameter, pipe wall thickness 2.9/3.6 – 14.2 mm		41 mm		
Metal pipes, 26.7 – 76.0 mm diameter, pipe wall thickness 2.2/2.9 – 14.2 mm		19/19 – 41 mm	EI 60-C/U	With local insulation (D), LD ≥ 500 mm, sustained
Metal pipes, 76.0 – 168.3 mm diameter, pipe wall thickness 2.9/3.6 – 14.2 mm		41 mm		
Copper pipes 28 – 54 mm diameter, pipe wall thickness 1.0/1.5 – 14.2 mm		19 – 41 mm	EI 120-C/U	With continued insulation (D), sustained
Copper pipes 54 – 89 mm diameter, pipe wall thickness 1.5/2.0 – 14.2 mm		41 mm		
Copper pipes 28 – 54 mm diameter, pipe wall thickness 1.0/1.5 – 14.2 mm		19/19 – 41 mm	EI 120-C/U	With local insulation (D), LD ≥ 500 mm, sustained
Copper pipes 54 – 89 mm diameter, pipe wall thickness 1.5/2.0 – 14.2 mm		41 mm		

### Continued insulation, sustained

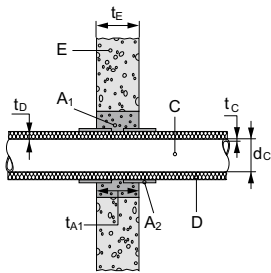

### Local insulation, sustained

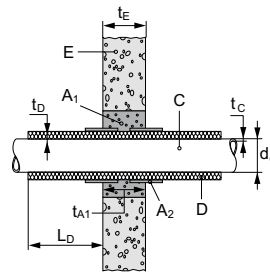

## METAL PIPES WITH FLEXIBLE ELASTOMETRIC FOAM INSULATION

Steel, cast iron, stainless steel, Ni alloys (NiCu, NiCr and NiMo alloys) and copper pipes.

Additional protection: Armaflex AF, thickness 25 mm over a length of 200 mm from the seal on both sides.

Penetration seal (A)/services (C)	Wall type and thickness ( $t_E$ )	Insulation thickness ( $t_b$ )	Classification E = Integrity I = Insulation	Other criteria, description
Metal pipes, 114.3 mm diameter, pipe wall thickness 7.1 – 14.2 mm	Rigid Wall $\geq 150$ mm minimum density of 550 kg/m <sup>3</sup>	$\geq 25$ mm	EI 120-C/U	With continued insulation (D), interrupted
Metal pipes, 114.3 mm diameter, pipe wall thickness 7.1 – 14.2 mm		25 mm		With local insulation (D), LD $\geq 780$ mm, interrupted

### Continued insulation, interrupted

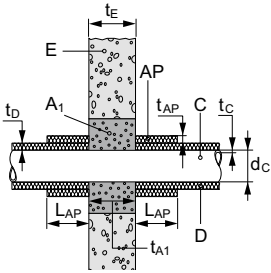

### Local insulation, interrupted

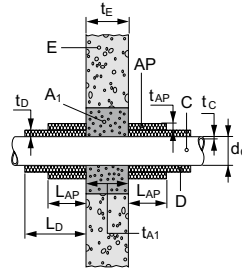

## SPECIFICATION FOR FLEXIBLE ELASTOMERIC FOAM (FEF) PRODUCTS SUITABLE FOR BEING USED AS PIPE INSULATION

Manufacturer	Product designation
Armacell International GmbH	Armaflex AF (CE marked according to EN 14304)

# PLASTIC PIPES

## With Hilti firestop collar CFS-C P

### PVC-U pipes

according to EN ISO 1452, EN ISO 15493 and DIN 8061/8062

Penetration seal (A)/services (C) Pipe diameter $d_e$	Wall type and thickness ( $t_e$ )	Classification E = Integrity I = Insulation	Other criteria, description
50 mm, pipe wall thickness 2.4 – 5.6 mm	Rigid Wall $\geq$ 150 mm minimum density of 550 kg/m <sup>3</sup>	EI 120-U/U	With Hilti firestop collar CFS-C P (A <sub>2</sub> ) on both sides of the seal, fixed together by M8 threaded rods, washers and nuts. Always use the appropriate collar size and number of hooks for the different pipe diameters.
63 mm, pipe wall thickness 3.0 – 4.7 mm		EI 120-U/U	
75 mm, pipe wall thickness 2.2 – 3.6 mm		EI 180-U/U	
90 mm, pipe wall thickness 2.7 – 4.3 mm		EI 120-U/U	
110 mm, pipe wall thickness 2.2 – 8.1 mm		EI 120-U/U	
110 mm, pipe wall thickness 8.1 mm		EI 180-U/U	
125 mm, pipe wall thickness 3.7 – 6.0 mm		EI 120-U/U	
160 mm, pipe wall thickness 2.5 – 11.8 mm		EI 120-U/U	
160 mm, pipe wall thickness 11.8 mm		EI 180-U/U	

### PE pipes

according to EN ISO 15494 and DIN 8074/8075

Penetration seal (A)/services (C) Pipe diameter $d_e$	Wall type and thickness ( $t_e$ )	Classification E = Integrity I = Insulation	Other criteria, description
50 mm, pipe wall thickness 2.9 mm	Rigid Wall $\geq$ 150 mm minimum density of 550 kg/m <sup>3</sup>	EI 180-U/U	With Hilti firestop collar CFS-C P (A <sub>2</sub> ) on both sides of the seal, fixed together by M8 threaded rods, washers and nuts. Always use the appropriate collar size and number of hooks for the different pipe diameters.
50 mm, pipe wall thickness 2.9 – 4.6 mm		EI 120-U/U	
63 mm, pipe wall thickness 1.8 – 5.8 mm		EI 90-U/U	
63 mm, pipe wall thickness 3.6 – 5.8 mm		EI 120-U/U	
75 mm, pipe wall thickness 1.9 – 6.8 mm		EI 120-U/U	
90 mm, pipe wall thickness 2.2 – 8.2 mm		EI 120-U/U	
110 mm, pipe wall thickness 2.7 – 10.0 mm		EI 120-U/U	
125 mm, pipe wall thickness 3.1 – 7.1 mm		EI 120-U/U	
160 mm, pipe wall thickness 4.0 – 9.1 mm		EI 120-U/U	
160 mm, pipe wall thickness 9.1 mm	EI 180-U/U		

### PE pipes

according to EN ISO 1519-1

Penetration seal (A)/services (C) Pipe diameter $d_e$	Wall type and thickness ( $t_e$ )	Classification E = Integrity I = Insulation	Other criteria, description
50 mm, pipe wall thickness 3.0 mm	Rigid Wall $\geq$ 150 mm minimum density of 550 kg/m <sup>3</sup>	EI 120-U/U	With Hilti firestop collar CFS-C P (A <sub>2</sub> ) on both sides of the seal, fixed together by M8 threaded rods, washers and nuts. Always use the appropriate collar size and number of hooks for the different pipe diameters.
63 mm, pipe wall thickness 3.0 mm		EI 180-U/U	
75 mm, pipe wall thickness 3.0 mm		EI 120-U/U	
90 mm, pipe wall thickness 3.5 mm		EI 180-U/U	
110 mm, pipe wall thickness 4.2 mm		EI 120-U/U	
125 mm, pipe wall thickness 4.8 mm		EI 120-U/U	
160 mm, pipe wall thickness 6.2 mm		EI 120-U/U	

# PLASTIC PIPES

## With Hilti firestop collar CFS-C

### PVC-U pipes

according to EN ISO 1452, EN ISO 15493 and DIN 8061/8062

Penetration seal (A)/services (C) Pipe diameter $d_c$	Wall type and thickness ( $t_E$ )	Classification E = Integrity I = Insulation	Other criteria, description
50mm, pipe wall thickness 2.2mm	Rigid Wall $\geq 150$ mm minimum density of 550 kg/m <sup>3</sup>	EI 180-U/C	With Hilti firestop collar CFS-C (A <sub>3</sub> ) on both sides of the seal, fixed together by M8 threaded rods, washers and nuts. Always use the appropriate collar size and number of hooks for the different pipe diameters.
110mm, pipe wall thickness 3.7 - 12.8mm			

### Plastic pipes

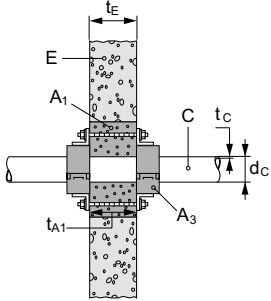

# PLASTIC PIPES

## With Hilti firestop wrap CFS-W

Hilti firestop wrap CFS-W (A<sub>4</sub>) on both sides of the mortar seal, flush with the surface of the seal.

### PVC pipes

according to EN ISO 1452, EN ISO 15493 and DIN 8061/8062

Penetration seal (A)/services (C) Pipe diameter d <sub>c</sub>	Wall type and thickness (t <sub>E</sub> )	Classification E = Integrity I = Insulation	Other criteria, description
≤ 32 mm, pipe wall thickness 1.8 mm	Rigid Wall ≥ 175 mm, minimum density of 1100 kg/m <sup>3</sup>	EI 240-U/C	CFS-W EL 1 layer
90 mm, pipe wall thickness 3.2 mm			CFS-W SG 90/3"
110 mm, pipe wall thickness 3.2 mm			CFS-W SG 110/4"
> 75 ≤ 110 mm, pipe wall thickness 3.2 mm			CFS-W EL 2 layers
160 mm, pipe wall thickness 3.2 – 13.0 mm			CFS-W SG 160/6"
> 125 ≤ 160 mm, pipe wall thickness 3.2 – 13.0 mm			CFS-W EL 3 layers

### PE pipes

according to EN ISO 15494 and DIN 8074/8075

Penetration seal (A)/services (C) Pipe diameter d <sub>c</sub>	Wall type and thickness (t <sub>E</sub> )	Classification E = Integrity I = Insulation	Other criteria, description
≤ 32 mm, pipe wall thickness 1.8 mm	Rigid Wall ≥ 175 mm, minimum density of 1100 kg/m <sup>3</sup>	EI 240-U/C	CFS-W EL 1 layer
90 mm, pipe wall thickness 2.7 mm			CFS-W SG 90/3"
110 mm, pipe wall thickness 2.7 mm			CFS-W SG 110/4"
> 75 ≤ 110 mm, pipe wall thickness 2.7 mm			CFS-W EL 2 layers
160 mm, pipe wall thickness 4.0 – 14.6 mm			CFS-W SG 160/6"
> 125 ≤ 160 mm, pipe wall thickness 4.0 – 14.6 mm			CFS-W EL 3 layers

### PE pipes

according to EN 1519-1

Penetration seal (A)/services (C) Pipe diameter d <sub>c</sub>	Wall type and thickness (t <sub>E</sub> )	Classification E = Integrity I = Insulation	Other criteria, description
160 mm, pipe wall thickness 6.2 mm	Rigid Wall ≥ 175 mm, minimum density of 1100 kg/m <sup>3</sup>	EI 180-U/C	CFS-W SG 160/6"
> 125 ≤ 160 mm, pipe wall thickness 6.2 mm			CFS-W EL 3 layers

### Plastic pipes

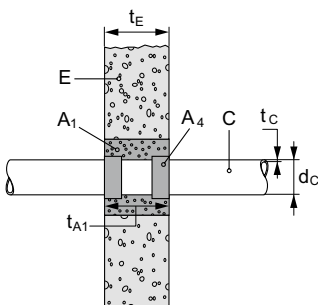

# CABLE PENETRATION, PIPE PENETRATION

## Rigid floors

The intended use of the Hilti firestop mortar CFS-M RG is to reinstate the fire resistance of: Rigid floors (E), minimum thickness 150 or 200 mm ( $t_f$ ), concrete or aerated concrete, minimum density of 550 or 2400 kg/m<sup>3</sup>. All penetrating items (cables, cable trays, conduits, metal pipes and plastic pipes) can be installed as a single, multiple or mixed configuration. Maximum opening sizes as well as minimum distances between penetrants and seal edges to be considered.

## CABLES, CABLE BUNDLES, CABLE TRAYS AND CONDUITS

### Additional protection

Depending on the required fire resistance, additional protection (AP) may be required.

AP: mineral wool mat, wrapped around cables/cable support (trays, ladders), Al-faced side outside, fixed with wire, width (length along the cables) 200 mm, thickness 30 mm.

Penetration seal (A) / services (C)	Wall type and thickness ( $t_f$ )	Classification E = Integrity I = Insulation			Other criteria, description
		Without additional protection (AP)	Without additional protection (AP)	With additional protection (AP)	
		200 mm seal thickness	150 mm seal thickness		
All sheathed cables up to 21 mm diameter		EI 90	EI 90	EI 90	
All sheathed cables from 21 mm to 80 mm diameter		EI 90	EI 60	EI 90	
All non-sheathed cables up to 17 mm diameter		EI 90	EI 45	EI 90	
All non-sheathed cables up to 24 mm diameter	Rigid Floor $\geq$ 150 mm minimum density of 550 kg/m <sup>3</sup>	EI 45	EI 45	EI 60	
Tied cable bundle max. diameter 100 mm with max. diameter of single cable 21 mm		EI 90	EI 90	EI 90	
Plastic conduits and tubes $\leq$ 16 mm with or without cables or cable supports		EI 120-U/C	EI 90-U/C	EI 90-U/C	In case a conduit is installed with open ends on both sides (U/U), conduit must be closed with e.g. Hilti Firestop Acrylic Sealant CFS-S ACR.
Steel conduits and tubes $\leq$ 16 mm with or without cables or cable supports		EI 120-C/U	EI 90-C/U	EI 90-C/U	

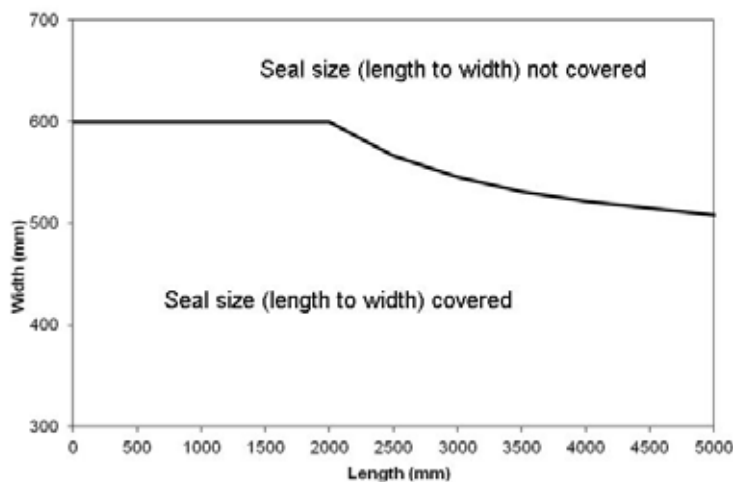

Seal sizes covered in floor type A application (length x width)

**Rigid floor type A according to clause 1.2.1 of the ETA (density  $\geq 550 \text{ kg/m}^3$ ), minimum thickness 150 mm**

**Penetration seal**

Type 1: Hilti Firestop Mortar CFS-M RG (A<sub>1</sub>), thickness ( $t_{A1}$ )  $\geq 150 \text{ mm}$  (opening depth tE filled completely).

Type 2: Hilti Firestop Mortar CFS-M RG (A<sub>1</sub>), thickness ( $t_{A1}$ )  $\geq 200 \text{ mm}$  (opening depth tE filled completely), with an overlap of the mortar seal of 50 mm over the top side of the floor on all sides of the opening.

Maximum distance to first service support construction: 300 mm.

Maximum seal size: see figure below

Minimum distances in mm (for illustration see below):

$s_1 = 0$  (distance between cables/cable supports and seal edge)

$s_2 = 0$  (distance between cable supports)

$s_3 = 0$  (distance between cables and upper seal edge)

$s_4 = 0$  (distance between cable supports and bottom seal edge)

$s_5 = 100 \text{ mm}$

$s_6 = 0$  (distance between metal pipes and seal edge)

$s_8 = 0$  (distance between metal pipes) in case of mineral wool insulation and linear arrangement; in case of cluster arrangement  $s_8 = 100 \text{ mm}$

$s_8 = 12$  (distance between metal pipes) in case of Armaflex insulation and linear arrangement; in case of cluster arrangement  $s_8 = 100 \text{ mm}$

$s_9 = 0$  (distance between plastic pipes/pipe closure devices and seal edge)

$s_{11} = 0$  (distance between plastic pipes/pipe closure devices) and linear arrangement; in case of cluster arrangement  $s_{11} = 100 \text{ mm}$

$s_{12} = 30$  (distance between metal pipes and plastic pipes/pipe closure devices)

$s_{13} = 30$  (distance between cables/cable supports and metal pipes)

$s_{14} = 18$  (distance between cables/cable supports and plastic pipes/pipe closure devices)

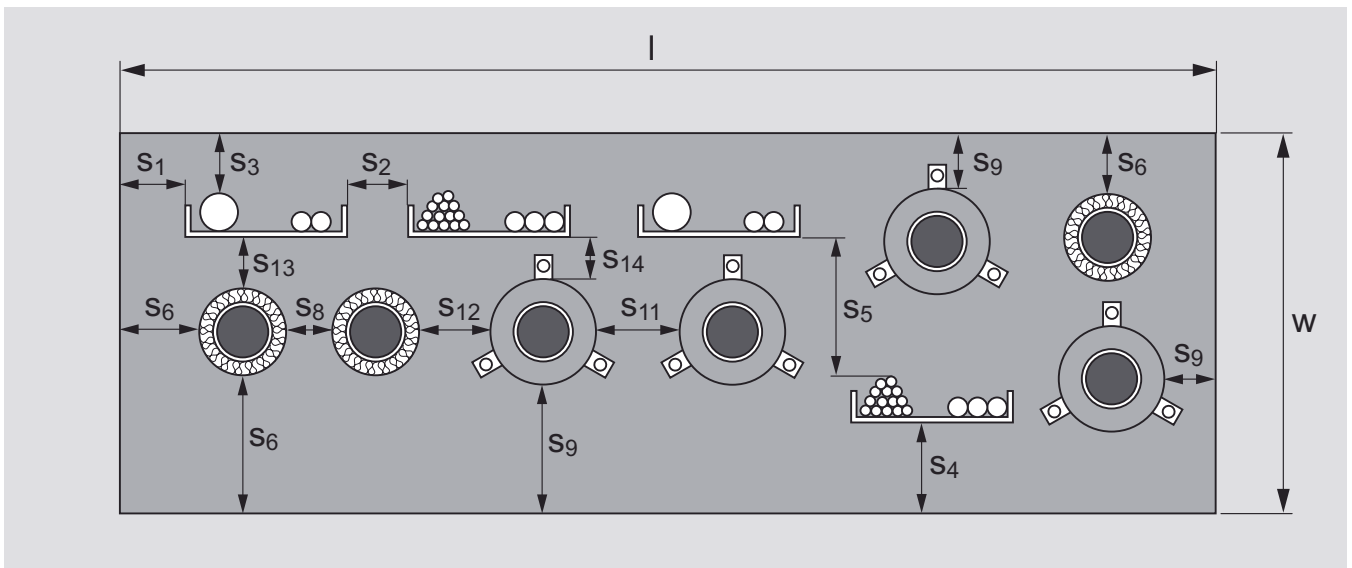

### Cable penetrations without add. protection

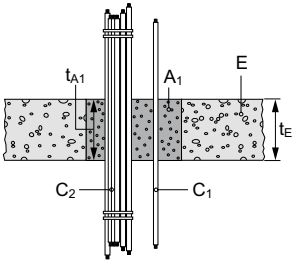
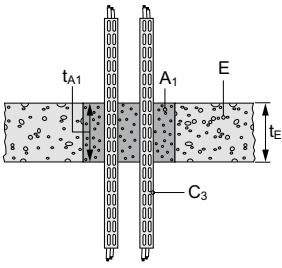

### Cable penetrations with additional protection (AP)

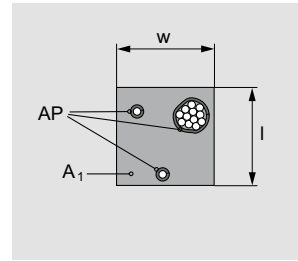
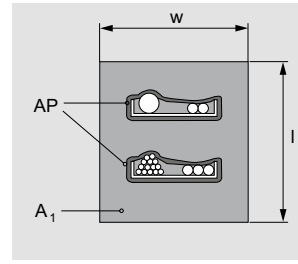
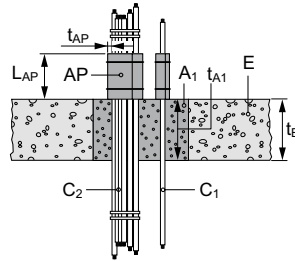
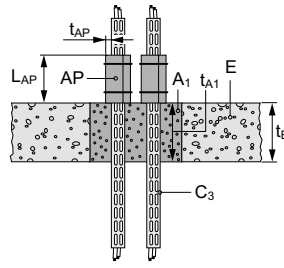

### Seal type with 200 mm seal thickness

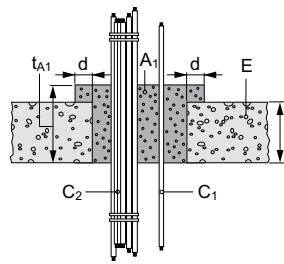
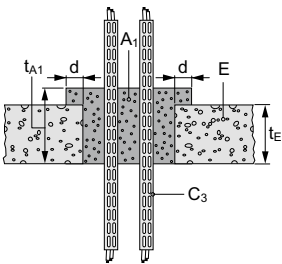



## METAL PIPES WITH MINERAL WOOL INSULATION

Steel, cast iron, stainless steel, Ni alloys (NiCu, NiCr and NiMo alloys) and copper pipes.  
No additional protection (AP).

Penetration seal (A) / services (C)	Floor type and thickness ( $t_f$ )	Insulation thickness ( $t_i$ )	Classification E = Integrity I = Insulation	Other criteria, description
Steel pipes 26.7 – 76.0 mm diameter, pipe wall thickness 2.2/2.9 – 14.2 mm	Rigid Floor $\geq 150$ mm minimum density of 550 kg/m <sup>3</sup>	$\geq 20$ mm	EI 120-C/U	With continued insulation (D), sustained
Steel pipes 76.0 – 168.3 mm diameter, pipe wall thickness 2.9/3.6 – 14.2 mm		$\geq 40$ mm		
Steel pipes 26.7 – 76.0 mm diameter, pipe wall thickness 2.2/2.9 – 14.2 mm		20 mm	EI 120-C/U	With local insulation (D), LD $\geq 500$ mm, sustained
Steel pipes 76.0 mm diameter, pipe wall thickness 2.9 – 14.2 mm		40 mm		
Steel pipes 76.0 – 168.3 mm diameter, pipe wall thickness 2.9/3.6 – 14.2 mm		40 mm		
Copper pipes 28 – 54 mm diameter, pipe wall thickness 1.0/1.5 – 14.2 mm		$\geq 20$ mm		
Copper pipes 54 – 89 mm diameter, pipe wall thickness 1.5/2.0 – 14.2 mm		$\geq 40$ mm		
Copper pipes 28 – 54 mm diameter, pipe wall thickness 1.0/1.5 – 14.2 mm		20 mm	EI 120-C/U	With local insulation (D), LD $\geq 500$ mm, sustained
Copper pipes 54 mm diameter, pipe wall thickness 1.5 – 14.2 mm		40 mm		
Copper pipes 54 – 89 mm diameter, pipe wall thickness 1.5/2.0 – 14.2 mm		40 mm		
Metal pipes, 114.3 mm diameter, pipe wall thickness 3.7 – 14.2 mm	Rigid Floor $\geq 150$ mm, minimum density of 2400 kg/m <sup>3</sup>	$\geq 40$ mm		
Metal pipes, 114.3 mm diameter, pipe wall thickness 3.7 – 14.2 mm		40 mm	EI 120-C/U	With local insulation (D), LD $\geq 800$ mm, interrupted

### Continued insulation, sustained

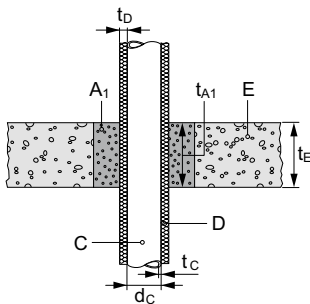

### Local insulation, sustained

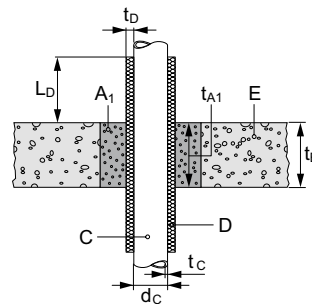

### Continued insulation, sustained

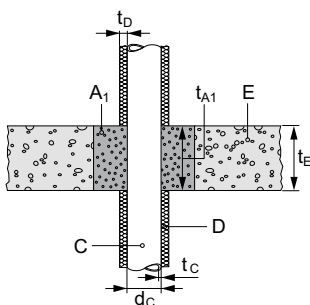

### Local insulation, interrupted

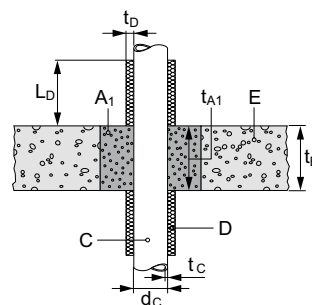

## METAL PIPES WITH FLEXIBLE ELASTOMETRIC FOAM INSULATION

Steel, cast iron, stainless steel, Ni alloys (NiCu, NiCr and NiMo alloys) and copper pipes.

With Hilti firestop bandage CFS-B (A2), two layers wrapped around pipe insulation on each side of the seal.

Penetration seal (A) /services (C)	Floor type and thickness ( $t_f$ )	Insulation thickness ( $t_i$ )	Classification E = Integrity I = Insulation	Other criteria, description
Metal pipes, 26.7 mm diameter, pipe wall thickness 2.2–14.2 mm	Rigid Floor $\geq 150$ mm minimum density of 550 kg/m <sup>3</sup>	19 mm	EI 120-C/U	
Metal pipes, 26.7–76.0 mm diameter, pipe wall thickness 2.2/2.9–14.2 mm		19–41 mm	EI 90-C/U	With continued insulation (D), sustained
Metal pipes, 76.0 mm diameter, pipe wall thickness 2.9–14.2 mm		41 mm	EI 120-C/U	
Metal pipes, 76.0–168.3 mm diameter, pipe wall thickness 2.9/3.6–14.2 mm		41 mm	EI 90-C/U	
Metal pipes, 26.7 mm diameter, pipe wall thickness 2.2–14.2 mm		19 mm	EI 120-C/U	
Metal pipes, 26.7–76.0 mm diameter, pipe wall thickness 2.2/2.9–14.2 mm		19–41 mm	EI 90-C/U	With local insulation (D), LD $\geq 500$ mm, sustained
Metal pipes, 76.0 mm diameter, pipe wall thickness 2.9–14.2 mm		41 mm	EI 120-C/U	
Metal pipes, 76.0–168.3 mm diameter, pipe wall thickness 2.9/3.6–14.2 mm		41 mm	EI 90-C/U	With local insulation (D), LD $\geq 700$ mm, sustained
Copper pipes 28 mm diameter, pipe wall thickness 1.0–14.2 mm		19 mm	EI 120-C/U	
Copper pipes 28–54 mm diameter, pipe wall thickness 1.0/1.5–14.2 mm		19–41 mm	EI 90-C/U	With continued insulation (D), sustained
Copper pipes 54–89 mm diameter, pipe wall thickness 1.5/2.0–14.2 mm		41 mm	EI 120-C/U	
Copper pipes 28 mm diameter, pipe wall thickness 1.0–14.2 mm		19 mm	EI 120-C/U	
Copper pipes 28–54 mm diameter, pipe wall thickness 1.0/1.5–14.2 mm		19–41 mm	EI 90-C/U	With local insulation (D), LD $\geq 500$ mm, sustained
Copper pipes 54 mm diameter, pipe wall thickness 1.5–14.2 mm		41 mm	EI 120-C/U	
Copper pipes 54–89 mm diameter, pipe wall thickness 1.5/2.0–14.2 mm		41 mm	EI 120-C/U	With local insulation (D), LD $\geq 800$ mm, sustained

### Continued insulation, sustained

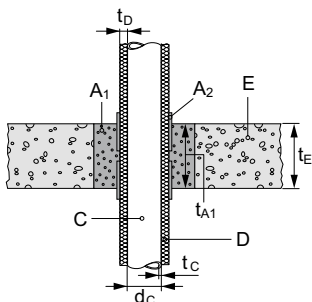

### Local insulation, sustained

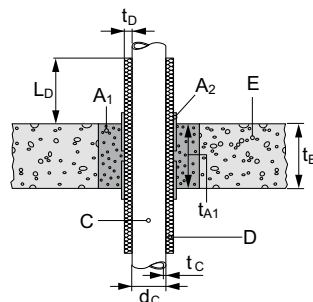

## METAL PIPES WITH FLEXIBLE ELASTOMETRIC FOAM INSULATION

Steel, cast iron, stainless steel, Ni alloys (NiCu, NiCr and NiMo alloys) and copper pipes.

Additional protection: Armaflex AF, thickness 25 mm over a length of 200 mm from the seal on the top side of the floor.

Penetration seal (A)/ services (C)	Floor type and thickness ( $t_e$ )	Insulation thickness ( $t_i$ )	Classification E = Integrity I = Insulation	Other criteria, description
Metal pipes, 114.3 mm diameter, pipe wall thickness 7.1 – 14.2 mm	Rigid Floor $\geq 150$ mm, minimum density of 2400 kg/m <sup>3</sup>	$\geq 25$ mm	EI 180-C/U	With continued insulation (D), interrupted
Metal pipes, 114.3 mm diameter, pipe wall thickness 7.1 – 14.2 mm		25 mm		With local insulation (D), LD $\geq 800$ mm, interrupted

### Continued insulation, interrupted

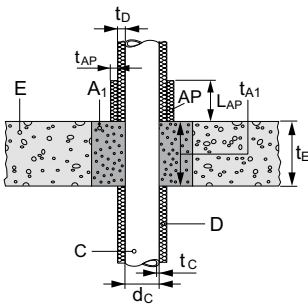

### Local insulation, interrupted

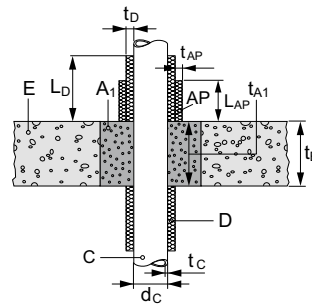

# PLASTIC PIPES

## With Hilti CFS-C P firestop collar

### PVC-U pipes

according to EN ISO 1452, EN ISO 15493 and DIN 8061/8062

Penetration seal (A)/services (C) Pipe diameter $d_c$	Floor type and thickness ( $t_f$ )	Classification E = Integrity I = Insulation	Other criteria, description
50 mm, pipe wall thickness 2.4 – 5.6 mm	Rigid Floor $\geq$ 150 mm minimum density of 550 kg/m <sup>3</sup>	EI 120-U/U	With Hilti firestop collar CFS-C P (A <sub>3</sub> ) fixed on the underside of the seal. Always use the appropriate collar size and number of hooks for the different pipe diameters.
63 mm, pipe wall thickness 3.0 – 4.7 mm			
75 mm, pipe wall thickness 2.2 – 3.6 mm			
90 mm, pipe wall thickness 2.7 – 4.3 mm			
110 mm, pipe wall thickness 1.8 – 8.1 mm			
125 mm, pipe wall thickness 3.7 – 6.0 mm			
160 mm, pipe wall thickness 2.5 – 11.8 mm			

### PE pipes

according to EN ISO 15494, DIN 8074/8075

Penetration seal (A)/services (C) Pipe diameter $d_c$	Floor type and thickness ( $t_f$ )	Classification E = Integrity I = Insulation	Other criteria, description
50 mm, pipe wall thickness 2.9 – 4.6 mm	Rigid Floor $\geq$ 150 mm minimum density of 550 kg/m <sup>3</sup>	EI 120-U/U	With Hilti firestop collar CFS-C P (A <sub>3</sub> ) fixed on the underside of the seal. Always use the appropriate collar size and number of hooks for the different pipe diameters.
63 mm, pipe wall thickness 1.8 – 5.8 mm			
75 mm, pipe wall thickness 1.9 – 6.8 mm			
90 mm, pipe wall thickness 2.2 – 8.2 mm			
110 mm, pipe wall thickness 2.7 – 10.0 mm			
125 mm, pipe wall thickness 3.1 – 7.1 mm			
160 mm, pipe wall thickness 4.0 – 9.1 mm			

### PE pipes

according to EN ISO 1519-1

Penetration seal (A)/services (C) Pipe diameter $d_c$	Floor type and thickness ( $t_f$ )	Classification E = Integrity I = Insulation	Other criteria, description
50 mm, pipe wall thickness 3.0 mm	Rigid Floor $\geq$ 150 mm minimum density of 550 kg/m <sup>3</sup>	EI 120-U/U	With Hilti firestop collar CFS-C P (A <sub>3</sub> ) fixed on the underside of the seal. Always use the appropriate collar size and number of hooks for the different pipe diameters.
63 mm, pipe wall thickness 3.0 mm			
75 mm, pipe wall thickness 3.0 mm			
90 mm, pipe wall thickness 3.5 mm			
110 mm, pipe wall thickness 4.2 mm			
125 mm, pipe wall thickness 4.8 mm			
160 mm, pipe wall thickness 6.2 mm			

# PLASTIC PIPES

## With Hilti firestop collar CFS-C

### PVC-U or PVC-C pipes

according to EN ISO 15493, EN ISO 1452 and DIN 8061 / 8062

Penetration seal (A)/ services (C) Pipe diameter $d_c$	Floor type and thickness ( $t_E$ )	Classification E = Integrity I = Insulation	Other criteria, description
50 mm, pipe wall thickness 2.0 mm	Rigid Floor $\geq 150$ mm, minimum density of 2400 kg/m <sup>3</sup>	EI 180-U/C	With Hilti firestop collar CFS-C (A <sub>3</sub> ) fixed on the underside of the seal. Always use the appropriate collar size and number of hooks for the different pipe diameters.
110 mm, pipe wall thickness 2.7 – 12.3 mm			

### Plastic pipes

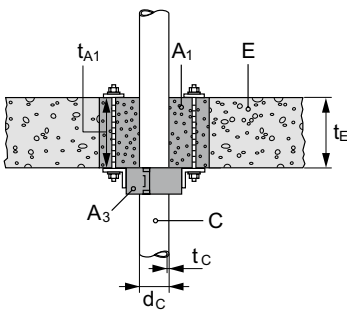

# PLASTIC PIPES

## With Hilti firestop wrap CFS-W

Hilti firestop wrap CFS-W (A<sub>4</sub>) on the underside of the mortar seal flush with the lower surface of the mortar seal.

### PVC-U pipes

according to EN ISO 1452, EN ISO 15493 and DIN 8061/8062

Penetration seal (A)/services (C) Pipe diameter d <sub>c</sub>	Floor type and thickness (t <sub>E</sub> )	Classification E = Integrity I = Insulation	Other criteria, description	
≤ 32 mm, pipe wall thickness 1.8 mm	Rigid Floor ≥ 175 mm, minimum density of 2400 kg/m <sup>3</sup>	EI 120-U/C	CFS-W EL 1 layer	
50 mm, pipe wall thickness 2.2–3.6 mm			CFS-W SG 50/1.5"	
63 mm, pipe wall thickness 2.2–3.6 mm			CFS-W SG 63/2"	
75 mm, pipe wall thickness 2.2–3.6 mm			CFS-W SG 75/2.5"	
> 32 ≤ 75 mm, pipe wall thickness 2.2–3.6 mm			CFS-W EL 1 layer	
90 mm, pipe wall thickness 3.2–6.0 mm			CFS-W SG 90/3"	
110 mm, pipe wall thickness 3.2–6.0 mm			CFS-W SG 110/4"	
> 75 ≤ 110 mm, pipe wall thickness 3.2–6.0 mm			CFS-W EL 2 layers	
125 mm, pipe wall thickness 3.7–6.0 mm			CFS-W SG 125/5"	
> 110 ≤ 125 mm, pipe wall thickness 3.7–6.0 mm			CFS-W EL 2 layers	
160 mm, pipe wall thickness 2.5–3.2 mm			EI 60-U/C	CFS-W SG 160/6"
> 125 ≤ 160 mm, pipe wall thickness 2.5–3.2 mm				CFS-W EL 3 layers
160 mm, pipe wall thickness 3.2–13.0 mm			EI 120-U/C	CFS-W SG 160/6"
> 125 ≤ 160 mm, pipe wall thickness 3.2–13.0 mm				CFS-W EL 3 layers

### PE pipes

according to EN ISO 15494 and DIN 8074/8075

Penetration seal (A)/services (C) Pipe diameter d <sub>c</sub>	Floor type and thickness (t <sub>E</sub> )	Classification E = Integrity I = Insulation	Other criteria, description
≤ 32 mm, pipe wall thickness 1.8 mm	Rigid Floor ≥ 175 mm, minimum density of 2400 kg/m <sup>3</sup>	EI 120-U/C	CFS-W EL 1 layer
50 mm, pipe wall thickness 1.9–6.8 mm			CFS-W SG 50/1.5"
63 mm, pipe wall thickness 1.9–6.8 mm			CFS-W SG 63/2"
75 mm, pipe wall thickness 1.9–6.8 mm			CFS-W SG 75/2.5"
> 32 ≤ 75 mm, pipe wall thickness 1.9–6.8 mm			CFS-W EL 1 layer
90 mm, pipe wall thickness 2.7–7.1 mm			CFS-W SG 90/3"
110 mm, pipe wall thickness 2.7–7.1 mm			CFS-W SG 110/4"
> 75 ≤ 110 mm, pipe wall thickness 2.7–7.1 mm			CFS-W EL 2 layers
125 mm, pipe wall thickness 3.2–7.1 mm			CFS-W SG 125/5"
> 110 ≤ 125 mm, pipe wall thickness 3.2–7.1 mm			CFS-W EL 2 layers
160 mm, pipe wall thickness 4.0–14.6 mm			CFS-W SG 160/6"
> 125 ≤ 160 mm, pipe wall thickness 4.0–14.6 mm			CFS-W EL 3 layers

## PE pipes

according to EN 1519-1

Penetration seal (A)/ services (C) Pipe diameter $d_c$	Floor type and thickness ( $t_E$ )	Classification E = Integrity I = Insulation	Other criteria, description
50 mm, pipe wall thickness 3.0 mm	Rigid Floor $\geq 175$ mm, minimum density of 2400 kg/m <sup>3</sup>	EI 120-U/C	CFS-W SG 50/1.5"
63 mm, pipe wall thickness 3.0 mm			CFS-W SG 63/2"
75 mm, pipe wall thickness 3.0 mm			CFS-W SG 75/2.5"
$\leq 75$ mm, pipe wall thickness 3.0 mm			CFS-W EL 1 layer
90 mm, pipe wall thickness 4.8 mm			CFS-W SG 90/3"
110 mm, pipe wall thickness 4.8 mm			CFS-W SG 110/4"
125 mm, pipe wall thickness 4.8 mm			CFS-W SG 125/5"
$> 75 \leq 125$ mm, pipe wall thickness 4.8 mm			CFS-W EL 2 layers
160 mm, pipe wall thickness 6.2 mm			CFS-W SG 160/6"
$> 125 \leq 160$ mm, pipe wall thickness 6.2 mm			CFS-W EL 3 layers

## Plastic pipes

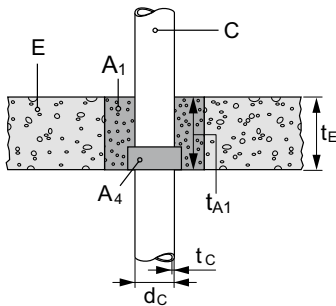

Specification for mineral wool products suitable for being used as additional protection (AP) for cables/cable supports: Stone wool according to EN 14303, reaction to fire class according to EN 13501-1 A1 or A2, thermal conductivity at 20 °C  $\leq$  0.040 W/(mK), density 35–45 kg/m<sup>3</sup>, surface faced with aluminum foil on one side.

The following list contains suitable products but may not be exhaustive:

Isover	Ultimate U TFA 34
Knauf	Lamella Forte LLMF AluR
Paroc	Lamella Mat 35 Alu Coat
Rockwool	Klimafix, Klimarock or Rockwool 133 (Lamella mat)

**Specification for mineral wool products suitable for being used as pipe insulation:**

Sustained insulation:

Isover	Coquilla AT-LR, Protect 1000 S alu, Protect BSR 90 alu
Paroc	Section AluCoat T
Rockwool	Conlit Pipe sections, Klimarock, RS 800 pipe sections

Interrupted insulation:

Stone wool acc. to EN 14303, class A2 or A1 acc. to EN 13501-1, Al-faced

**Specification for flexible elastomeric foam (FEF) products suitable for being used as pipe insulation:**

Armacell International GmbH	Armaflex AF (CE marked acc. to EN 14304)
-----------------------------	--



# CHARACTERISTICS OF CFS-M RG

## Additional Attributes

Hilti firestop products are comprehensively tested and individually matched to the technical requirements of a building's mechanical and electrical installations. In addition to their superior passive fire protection behavior, Hilti firestop products also meet increasingly significant requirements in building technology and also help designers and installers to meet these additional requirements. The assessment of fitness for use has been made in accordance with EOTA ETAG No 026 – Part 2.



Characteristics	Assessment of characteristics	Norm, standard, test
<b>Health and the environment</b> Air and gas permeability (gas tightness)	Gas permeability with the gases air, nitrogen (N <sub>2</sub> ), carbon dioxide (CO <sub>2</sub> ) and CH <sub>4</sub> (methane) with specific flow rates. See ETA for detailed results.	EN 1026
Dangerous substances	Does not contain dangerous substances from the list of the European Commission above the acceptable limits.	Material safety data sheet
Protection against noise (air-borne sound insulation)	Weighted element-normalized level difference: D <sub>n,w</sub> = 59dB Weighted sound reduction index R <sub>w</sub> = 52dB	EN ISO 20140-10 EN ISO 717-1
<b>Safety in use</b> Mechanical resistance and stability Resistance to impact/movement/adhesion	Safety in use: Internal walls: Highest risk zone type has been fulfilled (Type IV). For floors: soft body impact energy 600 Nm, hard body impact energy 10 Nm Serviceability: soft body impact energy 120 Nm, hard body impact energy 6 Nm	EOTA Technical Report TR001 A.1 and A.4
<b>Energy, economy and heat retention</b> Thermal properties	Heat conductivity (λ <sub>10</sub> , calculated): 0.232 W/mK.	EN 12667
Electrical properties	Volume resistivity: 133E+10 ± 50E+10Ωcm. Surface resistivity: 233E+08 ± 80E+08Ω.	DIN IEC 93 (VDE 0303 Part 30): 1993-12
Durability and serviceability	Category Y <sub>1,-5/+70°C</sub> (suitable for penetration seals intended for use at temperatures between -5°C and +70°C with no exposure to rain.	EOTA Technical Report TR 024 ETAG 026-2
Reaction to fire	Class A1	EN 13501-1

## SERVICE

With more than 20 years of experience worldwide, Hilti is one of the world's leading suppliers of firestop systems.

We actively help you manage your firestop projects better by providing:

- Quick engineering judgments
- Extensive technical literature
- On-site training and demonstrations
- Sophisticated jobsite logistics
- Assurance of conformity with specific application requirements
- International network of Hilti firestop specialists

Our network of experienced sales representatives, field engineers, firestop specialists and customer service representatives is just a phone call away (use the local toll-free Hilti number).

# HILTI FIRESTOP COLLAR CFS-C P

Firestopping for flammable pipes up to 250 mm in diameter with European Technical Approval.



## APPLICATIONS

- Sealing flammable pipes from 50 mm to 250 mm in diameter in penetrations through fire compartment walls and floors
- Pipe materials: PVC, PVC-U, PE, PE-HD, PE-X, PP, ABS, Al-composite
- Suitable for use in openings in concrete, aerated concrete, masonry, drywall, shaft wall and coated board.
- Different backfilling and sealing materials are covered

## ADVANTAGES

- Quick and easy closure without use of a tool
- Adjustable position tabs for simple fastening
- Sound decoupling strip based on PE (foam) can be used
- Low profile for tight installations

The European Technical Approval (ETA) and the technical data sheet can be obtained via your local Hilti contact.

Technical data	CFS-C P
Minimal wall thickness	100 mm
Minimal ceiling thickness	150 mm
Storage and transportation temperature - range	-5°C - 50°C
Close aperture with	Gypsum plaster, cementitious mortar, Hilti Firestop Acrylic Sealant CFS-S ACR
Expansion temperature	210 °C

Nominal pipe diameter	Number of hooks and fasteners	Order designation	Sales Quantity	Item Number
50 mm	2	Firestop collar CFS-C P 50/1.5"	1 pc	00435406
63 mm	2	Firestop collar CFS-C P 63/2"	1 pc	00435407
75 mm	3	Firestop collar CFS-C P 75/2.5"	1 pc	00435408
90 mm	3	Firestop collar CFS-C P 90/3"	1 pc	00435409
110 mm	4	Firestop collar CFS-C P 110/4"	1 pc	00435410
125 mm	4	Firestop collar CFS-C P 125/5"	1 pc	00435411
160 mm	6	Firestop collar CFS-C P 160/6"	1 pc	00435412
180 mm	8	Firestop collar CFS-C P 180/7"	1 pc	00435413
200 mm	8	Firestop collar CFS-C P 200/8"	1 pc	00435414
225 mm	10	Firestop collar CFS-C P 225/9"	1 pc	00435415
250 mm	12	Firestop collar CFS-C P 250/10"	1 pc	00435416

# FIRESTOP WRAP STRIP CFS-W SG

Firestopping for flammable pipes from 50 mm up to 160 mm in diameter with pre-cut wraps strips with European Technical Approval.



## APPLICATIONS

- Sealing flammable pipes from 50 mm to 160 mm in diameter in penetrations through fire compartment walls and floors
- Pipe materials: PE, PE-HD, PVC-U, PVC, PVC-C
- Suitable for use in openings in concrete, aerated concrete, masonry and drywall
- Different backfilling and sealing materials are covered

Technical data	CFS-W SG
Storage and transportation temperature – range	–5 °C – 50 °C
Expansion temperature	> 180 °C
Expansion ratio	1:15 load expansion, load = 5g/cm <sup>3</sup>
Compatibility other Hilti Firestop Products	Hilti Firestop Acrylic Sealant CFS-ACR

## ADVANTAGES

- Quick and easy closure without tools
- Ready-to-use pre-measured wrap strips for quick installation
- Sound decoupling strip based on PE (foam) can be used
- Ideal for very tight installations

The European Technical Approval (ETA) and the technical data sheet can be obtained via your local Hilti contact.

Dimensions (LxWxH)	Nominal pipe diameter	Recommended opening size	Order designation	Sales Quantity	Item Number
169 × 45 × 4.5 mm	50 mm	67 mm	Firestop wrap strip CFS-W SG 50/1.5"	2	00429549
210 × 45 × 4.5 mm	63 mm	77 mm	Firestop wrap strip CFS-W SG 63/2"	2	00429550
249 × 45 × 4.5 mm	75 mm	92 mm	Firestop wrap strip CFS-W SG 75/2.5"	2	00429551
311 × 45 × 9 mm	90 mm	112 mm	Firestop wrap strip CFS-W SG 90/3"	2	00429552
370 × 45 × 9 mm	110 mm	132 mm	Firestop wrap strip CFS-W SG 110/4"	2	00429553
421 × 45 × 9 mm	160 mm	152 mm	Firestop wrap strip CFS-W SG 125/5"	2	00429554
543 × 45 × 13.5 mm		202 mm	Firestop wrap strip CFS-W SG 160/6"	2	00429555

## FIRESTOP WRAP STRIP CFS-W EL

Firestopping for flammable pipes from 50 mm up to 160 mm with endless wraps strip providing an European Technical Approval.



### APPLICATIONS

- Sealing flammable pipes from 50 mm to 160 mm in diameter in penetrations through fire compartment walls and floors
- Pipe materials: PE, PE-HD, PVC-U, PVC, PVC-C
- Suitable for use in openings in concrete, aerated concrete, masonry and drywall
- Different backfilling and sealing materials are covered

### Technical data

### CFS-W EL

#### Storage and transportation temperature - range

-5°C - 50°C

#### Expansion temperature

> 180°C

#### Expansion ratio

1:15 load expansion, load = 5g/cm<sup>3</sup>

#### Compatibility other Hilti Firestop Products

Hilti Firestop Acrylic Sealant CFS-ACR

### ADVANTAGES

- Quick and easy closure without tools
- Highest flexibility – one product for pipe diameters from 50 mm to 160 mm
- Sound decoupling strip based on PE (foam) can be used
- Ideal for very tight installations

The European Technical Approval (ETA) and the technical data sheet can be obtained via your local Hilti contact.

Dimensions (L x W x H)	Pipe diameter - range	Order designation	Sales Quantity	Item Number
10000 x 45 x 4.5 mm	50 - 160 mm	Firestop wrap strip CFS-W EL W45/1.8"	1	00429556

# FIRESTOP ACRYLIC SEALANT CFS-S ACR

An acrylic based firestop sealant that provides movement capability in fire rated linear joint seals and penetration seals



## APPLICATIONS

- Within or between flexible wall constructions
- Vertical joints in / between wall constructions
- Horizontal joints in a wall abutting a floor, ceiling or roof
- Joints in floor construction
- Penetration seals (steel and copper pipes)

## ADVANTAGES

- Easy to dispense, apply and tool
- Strong adhesion to various base materials
- Low shrinkage after curing
- Excellent airborne sound insulation property
- Broad application temperature range



\* The European Technical Approval (ETA) can be obtained via your local Hilti contact or [www.hilti.com](http://www.hilti.com)

Technical data	CFS-S ACR
Chemical basis	Water-based acrylic dispersion
Volume shrinkage	< 20 %
Movement	12.5% (ISO 11600)
Cure Time (at 23°C/50% r.H.)	~ 3 mm/72 h
Application temperature range	5°C - 40°C
Storage and transportation temperature - range	5°C - 25°C
Shelf life (@73°F/23°C and 50% relative humidity)	24 month(s)
Reaction to fire class	D-s1d0 (EN13501-1)
Approvals*	ETA 10 / 0292, ETA 10 / 0389



Package	Volume	Color	Order designation	Sales Quantity	Item Number
Cartridge	310 ml	white	Firestop acrylic sealant CFS-S ACR	1 pc	435859
Cartridge	310 ml	white	Firestop acrylic sealant CFS-S ACR	1 pc	435860
Cartridge	310 ml	grey	Firestop acrylic sealant CFS-S ACR	1 pc	435862
Foil pack	580 ml	white	Firestop acrylic sealant CFS-S ACR	20 pc	435863
Pail	5 l	white	Firestop acrylic sealant CFS-S ACR	1 pc	435864
Pail	10 l	white	Firestop acrylic sealant CFS-S ACR	1 pc	2046766







Hilti Corporation  
9494 Schaan, Liechtenstein  
P +423-234 2965

[www.facebook.com/hiltigroup](https://www.facebook.com/hiltigroup)  
[www.hilti.group](http://www.hilti.group)