



HILTI, INC.
7250 Dallas Parkway
Suite 1000
Plano, TX 75024
(800) 879-8000
www.hilti.com
hiltitecheng@hilti.com

HILTI® HST3 AND HST3-R EXPANSION ANCHORS IN CONCRETE

CSI Sections:

- 03 15 19 Cast-In Concrete Anchors
- 05 05 19 Post-Installed Concrete Anchors

1.0 RECOGNITION

HILTI HST3 and HST3-R Expansion Anchors recognized in this report have been evaluated for use as torque-controlled, mechanical expansion anchors. The structural performance properties of the HILTI HST3 and HST3-R Expansion Anchors comply with the intent of the provisions of the following codes and regulations:

- 2024, 2021, 2018, and 2015 International Building Code® (IBC)
- 2024, 2021, 2018, and 2015 International Residential Code® (IRC)

2.0 LIMITATIONS

Use of the HILTI HST3 and HST3-R Expansion Anchors recognized in this report is subject to the following limitations:

2.1 The anchors shall be installed in accordance with the IBC or IRC, this report, and the manufacturer’s printed installation instructions. Where conflicts occur, the more restrictive governs.

2.2 The anchor sizes, dimensions, and minimum embedment depths shall be as set forth in this report.

2.3 The anchors shall be installed in cracked and uncracked normal-weight or lightweight concrete having a specified compressive strength, f'_c , between 17.2 MPa (2,500 psi) and 58.6 MPa (8,500 psi).

2.4 For calculation purposes, the compressive strength value, f'_c , shall not exceed 55.2 MPa (8,000 psi).

2.5 Strength design values shall be determined in accordance with Section 3.2.1 of this report. Loads applied to the anchors shall be adjusted in accordance with Section 1605.1 (2024 and 2021 IBC) or Sections 1605.1 and 1605.2 (2018 and 2015 IBC).

2.6 Allowable stress design values shall be determined in accordance with Section 3.2.2 of this report. Loads applied to the anchors shall be adjusted in accordance with Section 1605.1 or 1605.2 of the 2024 and 2021 IBC, or Sections 1605.1 and 1605.3 of the 2018 and 2015 IBC.

2.7 Anchor spacing, edge distance, and minimum concrete thickness shall comply with [Table 2](#) of this report.

2.8 Prior to installation, calculations and design details that demonstrate compliance with this report shall be submitted to the code official. The calculations and design details shall be prepared by a licensed design professional where required by the laws and statutes of the jurisdiction in which the construction is to occur.

2.9 Since suitable criteria for evaluating performance is not available, the use of the subject anchors for fatigue or shock loading conditions is beyond the scope of this report.

2.10 Use of zinc-plated carbon steel anchor is limited to dry, interior locations.

2.11 Periodic special inspection shall be provided in accordance with Section 3.4 of this report.

2.12 Where not otherwise prohibited in the applicable code, anchors are permitted for use with fire-resistant-rated construction provided at least one of the following conditions is satisfied:

- Anchors are used to resist wind or seismic forces only.
- Anchors that support fire-resistance-rated construction or gravity load-bearing structural elements are within a fire-resistance-rated envelope or a fire-resistance membrane, are protected by approved fire-resistance-rated materials, or have been evaluated for resistance to fire exposure in accordance with recognized standards.
- Anchors are used to support nonstructural elements.

2.13 Anchors are manufactured by Hilti, Inc. in Schaan, Liechtenstein.

3.0 PRODUCT USE

3.1 General: The HILTI HST3 and HST3-R torque-controlled mechanical expansion anchors are used to resist static, wind, and seismic (Seismic Design Categories A through F under the IBC) tension and shear loads in cracked and uncracked normal-weight concrete that has a specified compressive strength, f'_c , between 17.2 MPa (2,500 psi) and 58.6 MPa (8,500 psi). Cracked concrete shall be assumed except for anchors located in a region of the concrete member where analysis indicates no cracking (uncracked) at service loads or restrained shrinkage in accordance with ACI 318-19

The product described in this Uniform Evaluation Service (UES) Report has been evaluated as an alternative material, design or method of construction in order to satisfy and comply with the intent of the provision of the code, as noted in this report, and for at least equivalence to that prescribed in the code in quality, strength, effectiveness, fire resistance, durability and safety, as applicable, in accordance with Section 104.2.3 of the 2024 IBC and Section 104.11 of previous editions. This document shall only be reproduced in its entirety.





17.6.2.5 and 17.7.2.5 or ACI 318-14 17.4.2.6 and 17.5.2.7. Cracked concrete also shall be assumed for anchors in structures assigned to Seismic Design Category C, D, E, or F. The anchors comply with Section 1901.3 of the IBC. The anchors may be used where an engineered design is submitted in accordance with Section R301.1.3 of the IRC.

Installation instructions and information are set forth in Section 3.3, [Tables 1](#) through [4](#), and [Figures 1](#) and [3](#) of this report.

3.2 Design

3.2.1 Strength Design

3.2.1.1 General: The design strength of anchors complying with the 2024 and 2021 IBC, or with Section R301.1.3 of the 2024 and 2021 IRC, shall be determined in accordance with ACI 318-19 Chapter 17 and this report.

The design strength of anchors complying with the 2018 and 2015 IBC, or with Section R301.1.3 of the 2018 and 2015 IRC, shall be determined in accordance with ACI 318-14 Chapter 17 and this report.

The strength design of anchors shall comply with ACI 318-19 17.5.1.2 or ACI 318-14 17.3.1, except as required in ACI 318-19 17.10 or ACI 318-14 17.2.3. Strength reduction factors, ϕ , as given in ACI 318-19 17.5.3, ACI 318-14 17.3.3 and noted in [Tables 3](#) and [4](#) of this report, shall be used for load combinations calculated in accordance with Section 1605.1 of the 2024 and 2021 IBC or Sections 1605.1 and 1605.2 of the 2018 and 2015 IBC and ACI 318 (-19 or -14) 5.3. Under the IBC and IRC, anchor group effects shall be considered in accordance with ACI 318 (-19 or -14) 17.2.1.1.

[Tables 3 and 4](#) of this report provide the mean axial stiffness values, β , for each diameter in normal-weight concrete.

3.2.1.2 Requirements for Static Steel in Tension, N_{sa} : The nominal static steel strength of a single anchor in tension, N_{sa} , calculated in accordance with ACI 318-19 17.6.1.2 or ACI 318-14 17.4.1.2, as applicable, is given in [Tables 3 and 4](#) of this report. The strength reduction factors, ϕ , associated with ductile steel elements listed in [Tables 3 and 4](#) of this report shall be used.

3.2.1.3 Requirements for Static Concrete Breakout Strength in Tension, N_{cb} or N_{cbg} : The nominal concrete breakout strength of a single anchor or group of anchors in tension, N_{cb} or N_{cbg} , respectively shall be calculated in accordance with ACI 318-19 17.6.2 or ACI 318-14 17.4.2, with modifications as described herein. The basic concrete breakout strength in tension, N_b , shall be calculated in accordance with ACI 318-19 17.6.2.2 or ACI 318-14 17.4.2.2, using the values of h_{ef} and k_{cr} as listed in [Tables 3](#) and [4](#) of this report. The nominal concrete breakout strength in tension in regions where analysis indicates no cracking in accordance with ACI 318-19 17.6.2.5.1 or ACI 318-14

17.4.2.6 shall be calculated with the value of k_{uncr} as listed in [Tables 3 and 4](#) of this report and with $\psi_{c,N}=1.0$.

3.2.1.4 Requirements for Static Pullout Strength in Tension, N_{pn} : The nominal pullout strength of a single anchor in tension in accordance with ACI 318-19 17.6.3.1 and 17.6.3.2 or ACI 318-14 17.4.3.1 in cracked and uncracked concrete, $N_{p,cr}$ and $N_{p,uncr}$, respectively, is listed in [Tables 3 and 4](#) of this report. In lieu of ACI 318-19 17.6.3.3 or ACI 318-14 17.4.3.6, $\psi_{c,P} = 1.0$ for all design cases. The nominal pullout strength in cracked concrete shall be adjusted using Eq-1 of this report:

$$N_{pn,f'c} = N_{p,cr} \left(\frac{f'_c}{2,500} \right)^{0.5} \quad (\text{lb, psi}) \quad \text{Eq-1}$$

$$N_{pn,f'c} = N_{p,cr} \left(\frac{f'_c}{17.2} \right)^{0.5} \quad (\text{N, MPa})$$

where f'_c is the specified concrete compressive strength.

In regions where analysis indicates no cracking in accordance with ACI 318-19 17.6.3.3 or ACI 318-14 17.4.3.6, the nominal pullout strength in tension shall be adjusted using Eq-2 of this report:

$$N_{pn,f'c} = N_{p,uncr} \left(\frac{f'_c}{2,500} \right)^{0.5} \quad (\text{lb, psi}) \quad \text{Eq-2}$$

$$N_{pn,f'c} = N_{p,uncr} \left(\frac{f'_c}{17.2} \right)^{0.5} \quad (\text{N, MPa})$$

where f'_c is the specified concrete compressive strength.

Where values for $N_{p,cr}$ or $N_{p,uncr}$ are not listed in [Tables 3 and 4](#) of this report, the pullout strength in tension need not be evaluated.

3.2.1.5 Requirements for Static Steel Strength in Shear, V_{sa} : The nominal steel strength in shear, V_{sa} , of a single anchor in accordance with ACI 318-19 17.7.1.2 or ACI 318-14 17.5.1.2 is given in [Tables 3](#) and [4](#) of this report and shall be used in lieu of the values derived by calculation from ACI 318-19 Eq. 17.7.1.2b or ACI 318-14 Eq. 17.5.1.2b. The strength reduction factors, ϕ , associated with ductile steel elements listed in [Tables 3 and 4](#) of this report shall be used.

3.2.1.6 Requirements for Static Concrete Breakout Strength in Shear, V_{cb} or V_{cbg} : The nominal concrete breakout strength of a single anchor or group of anchors in shear, V_{cb} or V_{cbg} , respectively, shall be calculated in accordance with ACI 318-19 17.7.2 or ACI 318-14 17.5.2, with modifications as described herein. The basic concrete breakout strength in shear, V_b , shall be calculated in accordance with ACI 318-19 17.7.2.2.1 or ACI 318-14 17.5.2.2 using the values of l_e and d_a given in [Tables 3 and 4](#) of this report.

3.2.1.7 Requirements for Static Concrete Pryout Strength in Shear, V_{cp} or V_{cpg} : The nominal concrete pryout strength of a single anchor or group of anchors in shear, V_{cp} or V_{cpg} ,



shall be calculated in accordance with ACI 318-19 17.7.3 or ACI 318-14 17.5.3, modified using the value of k_{cp} provided in [Tables 3 and 4](#) of this report and the value of N_{cb} or N_{cbg} as calculated in Section 3.2.1.3 of this report.

3.2.1.8 Requirements for Seismic Design

3.2.1.8.1 General: For load combinations including seismic loads, the design calculations shall be performed in accordance with ACI 318-19 17.10 or ACI 318-14 17.2.3, as applicable. Modifications to ACI 318-19 17.10 and ACI 318-14 17.2.3 shall be applied under Section 1905.1.8 of the IBC.

The anchors shall be designed in accordance with ACI 318-19 17.10.4, 17.10.5, 17.10.6, or 17.10.7 or ACI 318-14 17.2.3.4, 17.2.3.5, or 17.2.3.6. Strength reduction factors, ϕ , are listed in [Tables 3 and 4](#) of this report.

All anchors listed in this report may be installed in structures assigned to IBC Seismic Design Categories A to F.

3.2.1.8.2 Seismic Tension: The nominal steel strength and nominal concrete breakout strength for anchors in tension shall be calculated in accordance with ACI 318-19 17.6.1 and 17.6.2 or ACI 318-14 17.4.1 and 17.4.2, as described in Sections 3.2.1.2 and 3.2.1.3 of this report. In accordance with ACI 318-19 17.6.3.2.1 or ACI 318-14 17.4.3.2, the appropriate value for pullout strength in tension for seismic loads, $N_{p,eq}$, as listed in [Tables 3 and 4](#) of this report, shall be used in lieu of $N_{p,cr}$. $N_{p,eq}$ may be adjusted by calculations in accordance with Eq-3 of this report.

$$N_{p,eq,f'c} = N_{p,eq} \left(\frac{f'_c}{2,500} \right)^{0.5} \quad (\text{lb, psi}) \quad \text{Eq-3}$$

$$N_{p,eq,f'c} = N_{p,eq} \left(\frac{f'_c}{17.2} \right)^{0.5} \quad (\text{N, MPa})$$

Where values for $N_{p,eq}$ are not listed in [Tables 3 and 4](#) of this report, the pullout strength in tension is not a controlling element and need not be evaluated.

3.2.1.8.3 Seismic Shear: The nominal concrete breakout strength and concrete pryout strength for anchors in shear shall be calculated in accordance with ACI 318-19 17.7.2 and 17.7.3 or ACI 318-14 17.5.2 and 17.5.3, as described in Sections 3.2.1.6 and 3.2.1.7 of this report. In accordance with ACI 318-19 17.7.1.2 or ACI 318-14 17.5.1.2, the appropriate value for nominal steel strength in shear for seismic loads, $V_{sa,eq}$, as listed in [Tables 3 and 4](#) of this report, shall be used in lieu of V_{sa} .

3.2.1.9 Requirements for Interaction of Tensile and Shear Forces: Anchors or groups of anchors that are subject to the effects of combined axial tension and shear forces shall be designed in accordance with ACI 318-19 17.8 or ACI 318-14 17.6.

3.2.1.10 Requirements for Critical Edge Distance: In applications where the design edge distance, c , is less than the critical edge distance, c_{ac} , and supplemental reinforcement to control splitting of the concrete is not present, the concrete breakout strength in tension for uncracked concrete, calculated according to ACI 318-19 17.6.2 or ACI 318-14 17.4.2, shall be further multiplied by the factor $\psi_{cp,N}$ given by Eq-4 of this report:

$$\psi_{cp,N} = \frac{c}{c_{ac}} \quad \text{Eq-4}$$

where the factor $\psi_{cp,N}$ need not be taken as less than $\frac{1.5h_{ef}}{c_{ac}}$, where c_{ac} and h_{ef} shall be as listed in [Tables 3 and 4](#) of this report. For all other cases, $\psi_{cp,N} = 1.0$.

3.2.1.11 Requirements for Minimum Member Thickness, Minimum Anchor Spacing, and Minimum Edge Distance: In lieu of ACI 318-19 17.9.2 or ACI 318-14 17.7.1, 17.7.3, and 17.7.5, values of c_{min} , s_{min} , and h_{min} shall comply with [Table 2](#) of this report. Additional combinations for minimum edge distance c_{min} and spacing s_{min} may be derived by linear interpolation between the given boundary values.

3.2.1.12 Requirements for Lightweight Concrete: For the use of anchors in lightweight concrete, the modification factor λ_a equal to 0.8 λ is applied to all values of $(f'_c)^{0.5}$ affecting N_n and V_n .

For ACI 318-19 (2024 and 2021 IBC or IRC) and ACI 318-14 (2018 and 2015 IBC or IRC), λ shall be determined in accordance with the corresponding version of ACI 318.

3.2.2 Allowable Stress Design

3.2.2.1 General: Design values for use with allowable stress design load combinations calculated in accordance with Section 1605.1 or 1605.2 of the 2024 and 2021 IBC or Sections 1605.1 and 1605.3 of the 2018 and 2015 IBC, shall be established using Eq-5 and Eq-6 of this report:

$$T_{allowable,ASD} = \frac{\phi N_n}{\alpha} \quad \text{Eq-5}$$

$$V_{allowable,ASD} = \frac{\phi V_n}{\alpha} \quad \text{Eq-6}$$

where:

$T_{allowable,ASD}$ = Allowable tension load (lbf or kN)

$V_{allowable,ASD}$ = Allowable shear load (lbf or kN)

ϕN_n = Lowest design strength of an anchor or anchor group in tension as determined with ACI 318 (-19 and -14) Chapter 17, and 2024 IBC Section 1905.7 or 2021, 2018 or 2015 IBC Section 1905.1.8, and Section 3.2 of this report, as applicable (lbf or kN)



- ϕV_n = Lowest design strength of an anchor or anchor group in shear as determined with ACI 318 (-19 and -14) Chapter 17, and 2024 IBC Section 1905.7 or 2021, 2018 or 2015 IBC Section 1905.1.8, and Section 3.2 of this report, as applicable (lbf or kN)
- α = Conversion factor calculated as a weighted average of the load factors for the controlling load combination. In addition, α shall include all applicable factors to account for non-ductile failure modes and required over-strength.

The requirements for member thickness, edge distance, and spacing, described in this report, shall apply. An example of allowable stress design values for illustrative purposes is shown in [Table 5](#) of this report.

3.2.2.2 Interaction of Tensile and Shear Forces: Anchors or groups of anchors that are subject to the effects of combined axial tension and shear forces shall be designed in accordance with ACI 318-19 17.8 or ACI 318-14 17.6, as follows:

For tension loads, $T_{applied} \leq 0.2T_{allowable,ASD}$, the full allowable load in shear shall be permitted.

For shear loads, $V_{applied} \leq 0.2V_{allowable,ASD}$, the full allowable load in tension shall be permitted.

For all other cases, Eq-7 of this report shall be satisfied:

$$\frac{T_{applied}}{T_{allowable,ASD}} + \frac{V_{applied}}{V_{allowable,ASD}} \leq 1.2 \quad \text{Eq-7}$$

3.3 Installation: Installation parameters and instructions are provided in [Tables 1](#) and [2](#), and [Figures 1](#) and [3](#) of this report. Anchor locations shall comply with this report and the plans and specifications approved by the code official. The HST3 and HST3-R Expansion Anchors shall be installed in accordance with the manufacturer’s printed installation instructions and this report. Anchors shall be installed in holes drilled into the concrete using carbide-tipped drill bits that comply with ANSI B212.15-1994. The nominal drill bit diameter shall be equal to that of the anchor and listed in [Table 1](#) of this report. The minimum drilled hole depth is listed in [Table 1](#) of this report. Prior to anchor installation, the dust and debris resulting from drilling shall be removed from the hole using a hand pump, compressed air, or a vacuum. The anchor shall be hammered into the predrilled and cleaned hole until the proper nominal embedment depth is achieved. The nut shall be tightened against the washer until the installation torque value, as listed in [Table 1](#) of this report, is achieved.

3.4 Special Inspection: Periodic special inspection is required in accordance with Section 1705.1.1 and Table 1705.3 of the IBC. The special inspector shall make periodic

inspections during anchor installation to verify anchor type, anchor dimensions, concrete type, concrete compressive strength, concrete member thickness, anchor spacing, anchor edge distance, drill bit type, drill bit size, hole dimensions, the hole cleaning method, installation torque procedure and verification and adherence to the manufacturer’s printed installation instructions. The special inspector shall be present as often as required in accordance with the “statement of special inspection”.

4.0 PRODUCT DESCRIPTION

4.1 Product Information: The Hilti HST3 and HST3-R Expansion Anchors are torque-controlled, mechanical expansion anchors that are comprised of four components: anchor body (stud), expansion element (clip), washer, and nut. A typical anchor is depicted in Figure 1 of this report. The anchor body has a tapered mandrel formed on the bottom end of the anchor and a threaded upper end. The expansion clip is fixed to the anchor body over the tapered mandrel during fabrication, and rotates freely on the anchor before installation.

The anchor is inserted into a predrilled hole in the hardened concrete using a mallet. The anchor is set by the application of an installation torque to the hex nut, which serves to expand the expansion clip against the concrete side of the bore-hole. Loads are transferred through the anchor to and from the concrete by friction.

The anchors are available in 8 mm, 10 mm, 12 mm, 16 mm, and 20 mm diameters of various lengths. The product names and sizes are presented in Table 1 of this report.

The HST3 anchor body is manufactured from carbon steel with electroplated zinc conforming to EN ISO 4042:1999. The expansion clips are fabricated from A4 stainless steel. The plain steel hex nuts conform to EN ISO 20898-2:2012, strength class 8, and the plain steel washers conform to EN ISO 4042:1999. The HST3-R anchor body, expansion clip, hexagonal nut, and washer are all manufactured from A4 stainless steel.

4.2 Material Information: Normal-weight and lightweight concrete shall comply with Sections 1903 and 1905 of the IBC.

5.0 IDENTIFICATION

Hilti HST3 and HST3-R Expansion Anchors are identified by dimensional characteristics and packaging. The packaging label lists the name and address of Hilti Inc., the manufacturing location, the anchor size and type, and the IAPMO UES evaluation report number (ER-578). The threaded end of each HST3 and HST3-R Expansion Anchor is stamped with a length identification code letter.



Either IAPMO Uniform Evaluation Service Mark of Conformity may also be used as shown below:

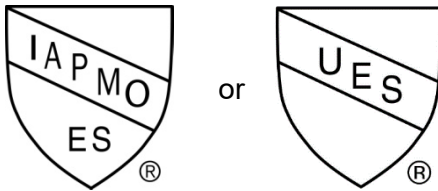

IAPMO UES ER-578

6.0 SUBSTANTIATING DATA

Testing and analytical data for cracked and uncracked concrete in accordance with ICC-ES Acceptance Criteria for Mechanical Anchors in Concrete Elements (AC193), Approved October 2017, editorially revised April 2024, and ACI 355.2-19, Qualification of Post-Installed Anchors in Concrete, including testing for seismic tension and seismic shear. Test reports are from laboratories accredited to ISO/IEC 17025.

7.0 STATEMENT OF RECOGNITION

This evaluation report describes the results of research completed by IAPMO Uniform Evaluation Service on HILTI HST3 AND HST3-R Expansion Anchors to assess conformance to the codes shown in Section 1.0 of this report and serves as documentation of the product certification. Products are manufactured at locations noted in Section 2.13 of this report under a quality control program with periodic inspection under the supervision of IAPMO UES.

For additional information about this evaluation report, please visit www.uniform-es.org or email us at info@uniform-es.org

TABLE 1 - HILTI HST3 AND HST3-R EXPANSION ANCHOR INSTALLATION PARAMETERS

Setting information	Symbol	Units	Nominal anchor diameter (mm)				
			M8	M10	M12	M16	M20
Nominal drill bit diameter	d_o	mm	8	10	12	16	20
Effective minimum embedment	$h_{ef, min}$	mm	47	60	70	85	101
Nominal minimum embedment	$h_{nom, min}$	mm	54	68	80	98	116
Minimum hole depth in concrete	$h_{l, min}$	mm	59	73	88	106	124
Fixture hole diameter	d_f	mm	9	12	14	18	22
Maximum thickness of fixture	$t_{fix, max}$	mm	195	220	270	370	310
Installation torque	T_{inst}	Nm	20	45	60	110	180
Maximum length of anchor	l_{max}	mm	260	280	350	475	450
Shaft diameter at the cone	d_R	mm	5.60	6.94	8.22	11.00	14.62
Length of expansion sleeve	l_s	mm	13.6	16.0	20.0	25.0	28.3
Minimum diameter of washer	$d_{w, min}$	mm	5.60	6.94	8.22	11.00	14.62
Width across flats of nut	S_W	mm	13	17	19	24	30

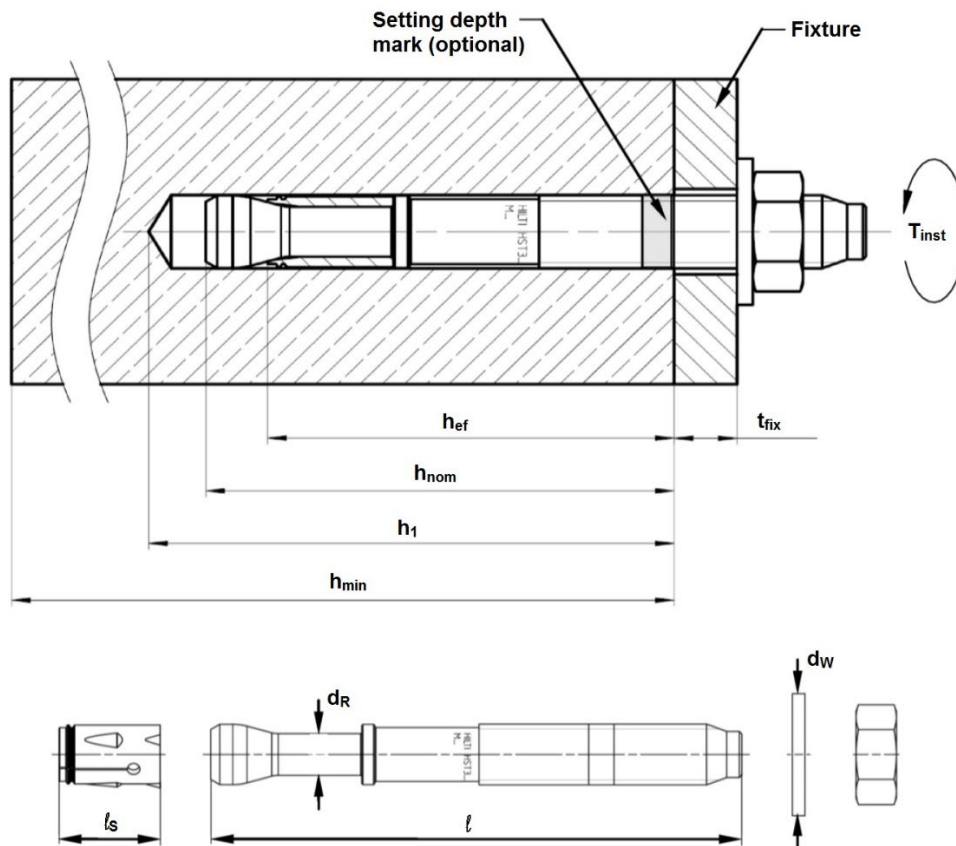

FIGURE 1 - HILTI HST3 AND HST3-R INSTALLATION PARAMETERS AND GEOMETRY

TABLE 2 - MINIMUM EDGE DISTANCE, SPACING, AND CONCRETE THICKNESS FOR HST3 AND HST3-R¹

Setting information	Symbol	Units	Nominal anchor diameter (mm)				
			M8	M10	M12	M16	M20
Effective minimum embedment	$h_{ef, min}$	mm	47	60	70	85	101
Minimum concrete thickness	h_{min}	mm	80	100	120	140	160
HST3							
Minimum edge distance	c_{min}	mm	40	60	60	65	120
	for $s \geq$	mm	65	90	155	185	180
Minimum anchor spacing	s_{min}	mm	35	40	50	80	120
	for $c \geq$	mm	50	100	115	135	180
HST3-R							
Minimum edge distance	c_{min}	mm	40	60	60	65	120
	for $s \geq$	mm	80	90	155	185	180
Minimum anchor spacing	s_{min}	mm	35	40	50	80	120
	for $c \geq$	mm	70	100	115	135	180
HST3							
Effective minimum embedment	$h_{ef, min}$	mm	47	60	70	85	101
Minimum concrete thickness	h_{min}	mm	100	120	140	160	200
HST3							
Minimum edge distance	c_{min}	mm	40	50	55	65	80
	for $s \geq$	mm	75	150	135	175	195
Minimum anchor spacing	s_{min}	mm	35	40	60	65	90
	for $c \geq$	mm	60	70	80	105	130
HST3-R							
Minimum edge distance	c_{min}	mm	40	50	55	65	80
	for $s \geq$	mm	50	105	110	175	180
Minimum anchor spacing	s_{min}	mm	35	40	60	65	90
	for $c \geq$	mm	50	70	70	105	130

¹ Linear interpolation for c_{min} and s_{min} is permitted. Figure 2 of this report illustrates the interpolation method.

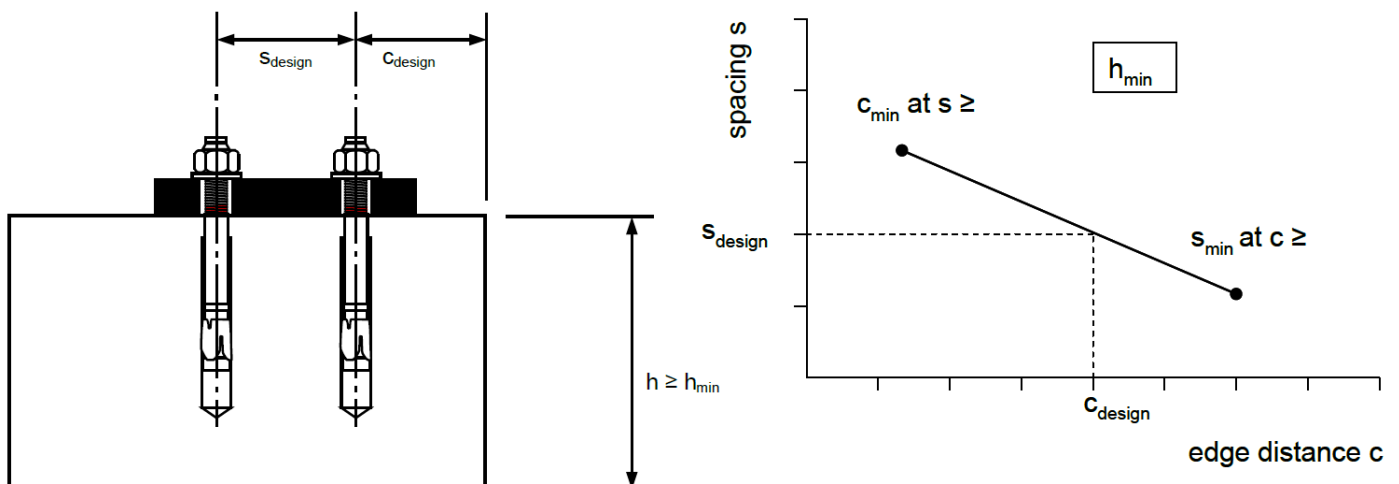

FIGURE 2 – INTERPOLATION OF MINIMUM EDGE AND SPACING DISTANCE



TABLE 3 - HILTI HST3 CARBON STEEL DESIGN INFORMATION

Design parameter	Symbol	Units	Nominal anchor diameter (mm)				
			M8	M10	M12	M16	M20
Anchor O.D.	d_a	mm	8	10	12	16	20
Effective min. embedment ¹	$h_{ef, min}$	mm	47	60	70	85	101
Tension, steel failure modes							
Strength reduction factor for steel in tension ²	$\phi_{sa, N}$	-	0.75				
Min. specified yield strength, threads	$f_{ya, threads}$	N/mm ²	640	640	640	576	560
Min. specified ult. strength, threads	$f_{uta, threads}$	N/mm ²	800	800	800	720	700
Effective-cross sectional steel area in tension, threads	$A_{se, N, thrd}$	mm ²	36.6	58.0	84.3	157.0	245.0
Min. specified yield strength, neck	$f_{ya, neck}$	N/mm ²	688	740	731	688	634
Min. specified ult. strength, neck	$f_{uta, neck}$	N/mm ²	800	860	850	800	740
Effective-cross sectional steel area in tension, neck	$A_{se, N, neck}$	mm ²	24.6	37.8	53.1	95.0	167.9
Nominal steel strength in tension	N_{sa}	kN	19.7	32.5	45.1	76.0	124.2
Tension, concrete failure modes							
Anchor category	-	-	1				
Strength reduction factor for concrete failure in tension, Condition B ³	$\phi_{c, N}$	-	0.65				
Effectiveness factor for uncracked concrete	k_{uncr}	-	10.0	10.0	10.0	10.0	10.0
Effectiveness factor for cracked concrete	k_{cr}	-	7.1	7.1	7.1	7.1	8.8
Modification factor for anchor resistance, tension, uncracked concrete ⁴	$\psi_{c, N}$	-	1.0				
Critical edge distance	c_{ac}	mm	71	115	110	128	192
Pullout strength in uncracked concrete ⁵	$N_{p, uncr}$	kN	11.0	NA	NA	NA	NA
Pullout strength in cracked concrete ⁵	$N_{p, cr}$	kN	8.5	NA	NA	NA	NA
Pullout strength in cracked conc., seismic ⁵	$N_{p, eq}$	kN	8.5	NA	NA	19.9	36.6
Tension, axial stiffness							
Axial stiffness for uncracked concrete	β_{uncr}	kN/mm	53.82	86.85	112.07	52.42	83.90
Axial stiffness for cracked concrete	β_{cr}	kN/mm	12.09	12.26	15.45	14.70	20.86
Shear, steel failure modes							
Strength reduction factor for steel in shear ³	$\phi_{sa, V}$	-	0.65				
Nominal steel strength in shear	V_{sa}	kN	12.9	19.1	27.6	47.6	64.3
Nominal steel strength in shear, seismic	$V_{sa, eq}$	kN	11.5	19.1	24.9	43.1	64.3
Shear, concrete failure modes							
Strength reduction factor for concrete breakout failure in shear, Condition B ³	$\phi_{c, V}$	-	0.70				
Load bearing length of anchor in shear	ℓ_e	mm	47	60	70	85	101
Effectiveness factor for prying	k_{cp}	-	1.0	1.0	2.0	2.0	2.0

¹ Figure 1 of this report illustrates the installation parameters.

² The HST3 is considered a ductile steel element in accordance with ACI 318-19 17.5.3 or ACI 314-14 17.3.3.

³ For use with the load combinations of ACI 318 (-19 and -14) Section 5.3, and 2024 and 2021 IBC Section 1605.1 or 2018 and 2015 IBC Section 1605.2.

Condition B applies where supplementary reinforcement in conformance with ACI 318-19 17.5.3 and Table 17.5.3 (b) or ACI 318-14 Section 17.3.3 (c) is not provided, or where pullout or prying strength governs. For cases where the presence of supplementary reinforcement can be verified, the resistance modification factors associated with Condition A may be used.

⁴ For all design cases, $\psi_{c, N} = 1.0$. The appropriate effectiveness factor for cracked concrete (k_{cr}) or uncracked concrete (k_{uncr}) shall be used.

⁵ For all design cases, $\psi_{c, P} = 1.0$. The tabular value for pullout strength is for a concrete compressive strength of 17.2 MPa. Pullout strength for concrete compressive strength greater than 17.2 MPa may be increased by multiplying the tabular pullout strength by $(f_c / 17.2)^{0.5}$. NA (not applicable) denotes that pullout strength does not need to be considered for design.



TABLE 4 - HILTI HST3-R STAINLESS STEEL DESIGN INFORMATION

Design parameter	Symbol	Units	Nominal anchor diameter (mm)				
			M8	M10	M12	M16	M20
Anchor O.D.	d_a	mm	8	10	12	16	20
Effective min. embedment ¹	$h_{ef, min}$	mm	47	60	70	85	101
Tension, steel failure modes							
Strength reduction factor for steel in tension ²	$\phi_{sa, N}$	-	0.75				
Min. specified yield strength, threads	$f_{ya, threads}$	N/mm ²	576	568	568	520	520
Min. specified ult. strength, threads	$f_{uta, threads}$	N/mm ²	720	710	710	650	650
Effective-cross sectional steel area in tension, threads	$A_{se, N, thrd}$	mm ²	36.6	58.0	84.3	157.0	245.0
Min. specified yield strength, neck	$f_{ya, neck}$	N/mm ²	619	654	688	628	593
Min. specified ult. strength, neck	$f_{uta, neck}$	N/mm ²	720	760	800	730	690
Effective-cross sectional steel area in tension, neck	$A_{se, N, neck}$	mm ²	24.6	37.8	53.1	95.0	167.9
Nominal steel strength in tension	N_{sa}	kN	17.7	28.7	42.5	69.4	115.8
Tension, concrete failure modes							
Anchor category	-	-	1				
Strength reduction factor for concrete failure in tension, Condition B ³	$\phi_{c, N}$	-	0.65				
Effectiveness factor for uncracked concrete	k_{unscr}	-	10.0	10.0	10.0	10.0	10.0
Effectiveness factor for cracked concrete	k_{cr}	-	7.1	7.1	7.1	7.1	8.8
Modification factor for anchor resistance, tension, uncracked concrete ⁴	$\psi_{c, N}$	-	1.0				
Critical edge distance	c_{ac}	mm	71	115	110	128	192
Pullout strength in uncracked concrete ⁵	$N_{p, unscr}$	kN	11.0	NA	NA	NA	NA
Pullout strength in cracked concrete ⁵	$N_{p, cr}$	kN	8.5	NA	NA	NA	NA
Pullout strength in cracked conc., seismic ⁵	$N_{p, eq}$	kN	8.5	NA	NA	19.9	36.6
Tension, axial stiffness							
Axial stiffness for uncracked concrete	β_{unscr}	kN/mm	53.82	86.85	112.07	52.42	83.90
Axial stiffness for cracked concrete	β_{cr}	kN/mm	12.09	12.26	15.45	14.70	20.86
Shear, steel failure modes							
Strength reduction factor for steel in shear ²	$\phi_{sa, V}$	-	0.65				
Nominal steel strength in shear	V_{sa}	kN	10.1	24.4	28.9	61.2	79.2
Nominal steel strength in shear, seismic	$V_{sa, eq}$	kN	9.8	22.1	28.9	60.7	51.5
Shear, concrete failure modes							
Strength reduction factor for concrete breakout failure in shear, Condition B ³	$\phi_{c, V}$	-	0.70				
Load bearing length of anchor in shear	ℓ_e	mm	47	60	70	85	101
Effectiveness factor for prying	k_{cp}	-	1.0	1.0	2.0	2.0	2.0

¹ See Figure 1 of this report.

² The HST3 is considered a ductile steel element in accordance with ACI 318-19 17.5.3 or ACI 314-14 17.3.3.

³ For use with the load combinations of ACI 318 (-19 and -14) Section 5.3, and 2024 and 2021 IBC Section 1605.1 or 2018 and 2015 IBC Section 1605.2. Condition B applies where supplementary reinforcement in conformance with ACI 318-19 17.5.3 and Table 17.5.3 (b) or ACI 318-14 Section 17.3.3 (c) is not provided, or where pullout or prying strength governs. For cases where the presence of supplementary reinforcement can be verified, the resistance modification factors associated with Condition A may be used.

⁴ For all design cases, $\psi_{c, N} = 1.0$. The appropriate effectiveness factor for cracked concrete (k_{cr}) or uncracked concrete (k_{unscr}) shall be used.

⁵ For all design cases, $\psi_{c, P} = 1.0$. The tabular value for pullout strength is for a concrete compressive strength of 17.2 MPa. Pullout strength for concrete compressive strength greater than 17.2 MPa may be increased by multiplying the tabular pullout strength by $(f'_c / 17.2)^{0.5}$. NA (not applicable) denotes that pullout strength does not need to be considered for design.

TABLE 5 – EXAMPLE ALLOWABLE LOAD VALUES FOR ILLUSTRATIVE PURPOSES^{1,2,3,4,5}

Nominal anchor diameter (mm)	Embedment depth (mm)	Allowable tension load (kN)
		HST3 and HST3-R
d_a	h_{ef}	$f'_c = 17.2 \text{ MPa}$
M8	47	4.8
M10	60	8.5
M12	70	10.7
M16	85	14.3
M20	101	18.5

¹ Single anchor with static tension load only. Allowable load is the minimum of $\phi N_{cb}/\alpha_{ASD}$ and $\phi N_{p,uncr}/\alpha_{ASD}$.

² Concrete will remain uncracked for the life of the anchorage.

³ Controlling strength design load combination from ACI 318-14 Section 5.3, 1.2D + 1.6L. The corresponding ASD load combination is 1.0D + 1.0L. This example will use 30% dead load and 70% live load.

⁴ Calculation of weighted average, $\alpha_{ASD} = (0.3*1.2 + 0.7*1.6) / (0.3*1.0 + 0.7*1.0) = 1.48$.

⁵ $c_{a1} = c_{a2} \geq c_{ac}$; $s \geq 3h_{ef}$; $h \geq h_{min}$

⁶ Values are for Condition B assuming supplementary reinforcement to control splitting is not provided.

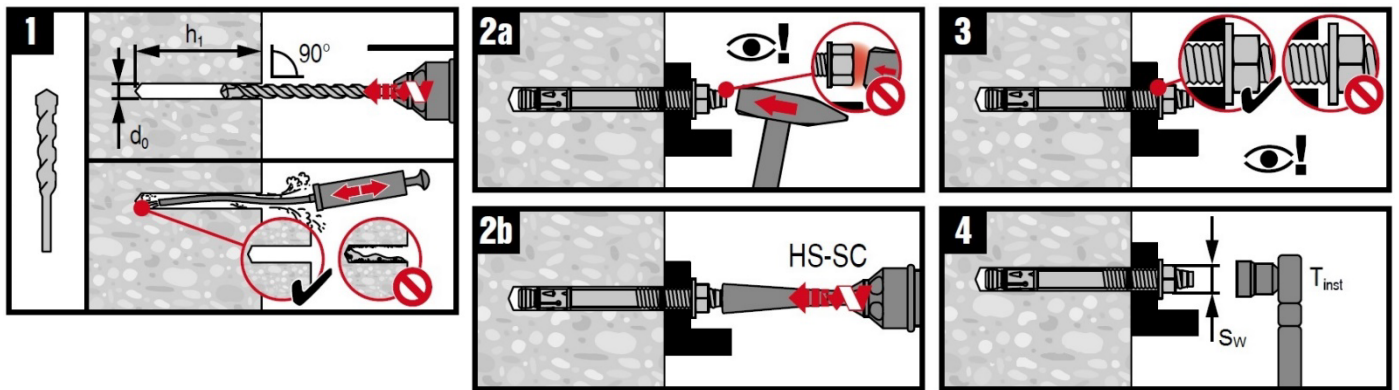

FIGURE 3 – HST3 AND HST3-R INSTALLATION INSTRUCTIONS